

Service Manual



WCA330 & WCA380 3GHz & 8GHz Wireless Communication Analyzers 070-A795-50

Warning

The servicing instructions are for use by qualified personnel only. To avoid personal injury, do not perform any servicing unless you are qualified to do so. Refer to all safety summaries prior to performing service.

www.tektronix.com

Copyright © Tektronix Japan, Ltd. All rights reserved.

Copyright © Tektronix, Inc. All rights reserved.

Tektronix products are covered by U.S. and foreign patents, issued and pending. Information in this publication supercedes that in all previously published material. Specifications and price change privileges reserved.

Tektronix Japan, Ltd., 5-9-31 Kitashinagawa, Shinagawa-ku, Tokyo 141-0001 Japan

Tektronix, Inc., P.O. Box 500, Beaverton, OR 97077

TEKTRONIX and TEK are registered trademarks of Tektronix, Inc.

WARRANTY

Tektronix warrants that the products that it manufactures and sells will be free from defects in materials and workmanship for a period of one (1) year from the date of shipment. If a product proves defective during this warranty period, Tektronix, at its option, either will repair the defective product without charge for parts and labor, or will provide a replacement in exchange for the defective product.

In order to obtain service under this warranty, Customer must notify Tektronix of the defect before the expiration of the warranty period and make suitable arrangements for the performance of service. Customer shall be responsible for packaging and shipping the defective product to the service center designated by Tektronix, with shipping charges prepaid. Tektronix shall pay for the return of the product to Customer if the shipment is to a location within the country in which the Tektronix service center is located. Customer shall be responsible for paying all shipping charges, duties, taxes, and any other charges for products returned to any other locations.

This warranty shall not apply to any defect, failure or damage caused by improper use or improper or inadequate maintenance and care. Tektronix shall not be obligated to furnish service under this warranty a) to repair damage resulting from attempts by personnel other than Tektronix representatives to install, repair or service the product; b) to repair damage resulting from improper use or connection to incompatible equipment; c) to repair any damage or malfunction caused by the use of non-Tektronix supplies; or d) to service a product that has been modified or integrated with other products when the effect of such modification or integration increases the time or difficulty of servicing the product.

THIS WARRANTY IS GIVEN BY TEKTRONIX IN LIEU OF ANY OTHER WARRANTIES, EXPRESS OR IMPLIED. TEKTRONIX AND ITS VENDORS DISCLAIM ANY IMPLIED WARRANTIES OF MERCHANTABILITY OR FITNESS FOR A PARTICULAR PURPOSE. TEKTRONIX' RESPONSIBILITY TO REPAIR OR REPLACE DEFECTIVE PRODUCTS IS THE SOLE AND EXCLUSIVE REMEDY PROVIDED TO THE CUSTOMER FOR BREACH OF THIS WARRANTY. TEKTRONIX AND ITS VENDORS WILL NOT BE LIABLE FOR ANY INDIRECT, SPECIAL, INCIDENTAL, OR CONSEQUENTIAL DAMAGES IRRESPECTIVE OF WHETHER TEKTRONIX OR THE VENDOR HAS ADVANCE NOTICE OF THE POSSIBILITY OF SUCH DAMAGES.

Service Options

Tektronix provides service to cover repair under warranty as well as other services that are designed to meet your specific service needs. Advancing technology has brought incredible change to the power of measurement instruments. Manufacturing methods and calibration techniques have been revolutionized, making the service challenge tougher than ever. By using Tektronix as your service provider you make use of our technology and product knowledge, our world-wide logistics infrastructure, and our ISO9000 approved service centers. Tektronix technicians are trained on the latest products and are equipped with the most current information on product improvements and upgrades for optimum product performance.

Warranty Repair Service. Tektronix technicians provide warranty service at most Tektronix service locations worldwide. The warranty period for this product can be found behind the title page in this manual.

Calibration and Repair Service. Tektronix offers calibrations, non-warranty repair, and support for customers performing their own service. Where appropriate, calibrations are compliant to ANSI/NCSL Z-540/ISO GUIDE 25 and ISO9000 Quality Systems. If you prefer to perform your own service, Tektronix supports repair to the replaceable-part level through providing for circuit board exchange. All services can be purchased through a variety of agreements to fit your specific requirements.

For more information, regarding service offerings or service locations worldwide, please see the Tektronix product catalog or visit us on our Customer Services web site at:

Tektronix.com/Measurement/Service

Table of Contents

General Safety Summary	xi
Service Safety Summary	xiii
Preface	xv
Introduction	xix

Specifications

Product Overview	1-1
Features	1-2
Targets	1-3
Difference between WCA330 and WCA380	1-3
Specifications	1-5
Warranted Characteristics	1-5
Typical Characteristics	1-10
Nominal Traits	1-12
Certification and Compliances	1-20

Operating Information

Installation	2-1
Supplying Operating Power	2-1
Operating Environment	2-3
Connecting the Power Cord	2-4
Powering On	2-5
Adjusting the Display Tilt Angle	2-9
Powering Off	2-10
Repackaging Instructions	2-12
Installed Options	2-12
Operating Instructions	2-13
Preparations	2-13
Connecting the Signal Generator	2-14
Applying Power	2-15
Setting the Analyzer with Basic Configuration Patterns	2-17
Measuring a Digital Modulated Signal	2-20
Changing Hardware Settings	2-22
View Definitions and Layout	2-27
Averaging and Compared Display	2-32
Peak Search and Zoom	2-34
Delta Markers	2-37

Theory of Operation

Theory of Operation	3-1
Module Overview	3-1

Performance Verification

Performance Verification	4-1
Conventions	4-2
Self Tests	4-3
Initial Test	4-4
Self Calibration	4-5
Diagnostics	4-9
Performance Tests	4-11
Prerequisites	4-12
Equipment Required	4-13
Auto Test Procedures	4-15
Baseband Tests	4-19
RF Tests	4-22
Manual Test Procedures	4-34
Test Record	4-53

Adjustment Procedures

Adjustment Procedures	5-1
Requirements for Adjustments	5-2
Equipment Required	5-2
Adjustments	5-4
Auto Calibration Procedures	5-13

Maintenance

Maintenance	6-1
Related Maintenance Procedures	6-1
Preparation	6-2
Inspection and Cleaning	6-4
Removal and Installation Procedures	6-9
Preparation	6-9
Access Procedure	6-19
Procedures for External Modules	6-20
Procedures for Inner-Chassis Modules	6-24
Procedures for Power Supply Modules	6-36
Procedures for Mother Board and its Daughter Boards	6-44
Procedures for Front Panel Modules	6-52
Procedures for Rear Chassis Modules	6-59
Troubleshooting	6-63
Troubleshooting Procedure	6-63
Diagnostics	6-64
Symptoms and Faulty Modules	6-87

Options

Options and Accessories	7-1
Options	7-1
Standard Accessories	7-2
Optional Accessories	7-2

Electrical Parts List

Electrical Parts List	8-1
------------------------------------	------------

Diagrams

Diagrams	9-1
-----------------------	------------

Mechanical Parts List

Mechanical Parts List	10-1
Parts Ordering Information	10-1
Using the Replaceable Parts List	10-2

List of Figures

Figure 1–1: WCA330/WCA380 wireless communication analyzer ..	1–1
Figure 2–1: AC inlet on the rear panel	2–4
Figure 2–2: Mouse connector location (rear panel)	2–5
Figure 2–3: Principal power switch (rear panel)	2–6
Figure 2–4: Power switch (ON/STANDBY)	2–6
Figure 2–5: New clock settings dialog box	2–7
Figure 2–6: Display of self test results upon power-up (upper left of screen)	2–7
Figure 2–7: Initial screen	2–8
Figure 2–8: Angular adjustment of tilt display	2–9
Figure 2–9: Cable connection	2–14
Figure 2–10: Power switch	2–15
Figure 2–11: Initial screen	2–16
Figure 2–12: CONFIG:MODE key and the menu	2–17
Figure 2–13: Control of the start and stop of measurement	2–18
Figure 2–14: Spectrum measurement with a span of 3 GHz	2–18
Figure 2–15: Status display area	2–19
Figure 2–16: Four-view display for digital modulation analysis	2–20
Figure 2–17: Measuring the digital modulated signal – Span 3 GHz .	2–21
Figure 2–18: SETUP:FREQ key location	2–22
Figure 2–19: Freq side menu item available for numeric input	2–23
Figure 2–20: Numeric input keypad	2–23
Figure 2–21: Span side menu item available for numeric input	2–24
Figure 2–22: Setup display areas	2–25
Figure 2–23: Views resulting from changes to the frequency and span settings	2–26
Figure 2–24: CONFIG:VIEW key and its submenu	2–27
Figure 2–25: Selecting the Waterfall view	2–28
Figure 2–26: Making changes to View D	2–29
Figure 2–27: Four-view display layout	2–30
Figure 2–28: VIEW keys (view control keys)	2–30
Figure 2–29: View B display (1-view display)	2–31
Figure 2–30: Averaging and compared waveform display	2–33
Figure 2–31: Signal acquisition in the Zoom mode	2–35
Figure 2–32: Example of zooming	2–36

Figure 2–33: Moving the markers by peak search	2–37
Figure 2–34: Measurement example using the delta markers	2–39
Figure 4–1: Display of the self test results (view of upper left corner)	4–4
Figure 4–2: Displaying UNCAL	4–5
Figure 4–3: Running the self gain-calibration	4–6
Figure 4–4: Running calibration and diagnostics	4–8
Figure 4–5: Execution results of diagnostic routines (View C)	4–10
Figure 4–6: Executing the performance test routines	4–18
Figure 4–7: Initial test hookup	4–20
Figure 4–8: Initial test hookup	4–22
Figure 4–9: Initial test hookup	4–24
Figure 4–10: Initial test hookup	4–26
Figure 4–11: Initial test hookup	4–28
Figure 4–12: Initial test hookup	4–30
Figure 4–13: Initial test hookup	4–32
Figure 4–14: Initial test hookup	4–35
Figure 4–15: Initial test hookup	4–36
Figure 4–16: Initial test hookup	4–38
Figure 4–17: Initial hookup for setting up the power meter and sensor	4–42
Figure 4–18: Hookup for calibrating the power sensor	4–43
Figure 4–19: Hookup for setting the signal generator	4–44
Figure 4–20: Hookup for checking the reference level accuracy	4–44
Figure 4–21: Hookup for setting the microwave signal generator ...	4–46
Figure 4–22: Hookup for checking the reference level accuracy	4–46
Figure 4–23: Initial test hookup	4–51
Figure 5–1: Initial test hookup	5–4
Figure 5–2: Adjustment location for the clock frequency	5–5
Figure 5–3: Adjustment location of TFT panel luminance	5–7
Figure 5–4: Location of the down converter unit 1 and 2	5–8
Figure 5–5: Test hookup	5–10
Figure 5–6: Location of labeling the “GAIN” and “OFFSET” values	5–11
Figure 5–7: Test hookup	5–12
Figure 5–8: Downloading the setup files for AWG520	5–14
Figure 5–9: Initial test hookup	5–16
Figure 5–10: Hookup for calibrating the power sensor	5–17

Figure 5–11: Test hookup	5–20
Figure 5–12: Hookup for calibrating the power sensor	5–21
Figure 5–13: Initial test hookup	5–24
Figure 5–14: Initial test hookup	5–26
Figure 5–15: Initial test hookup	5–28
Figure 5–16: Initial test hookup	5–29
Figure 5–17: Initial test hookup	5–31
Figure 5–18: Initial test hookup	5–33
Figure 5–19: Initial test hookup	5–35
Figure 5–20: Displaying the Windows 98 accessory menu	5–38
Figure 6–1: Analyzer orientation	6–12
Figure 6–2: External modules	6–13
Figure 6–3: Inner-chassis modules	6–14
Figure 6–4: Power supply modules	6–15
Figure 6–5: Mother board and its daughter boards	6–16
Figure 6–6: Front panel modules	6–17
Figure 6–7: Rear chassis modules	6–18
Figure 6–8: Guide to removal procedures	6–19
Figure 6–9: Line cord and cabinet removal	6–21
Figure 6–10: Handle and foot removal	6–22
Figure 6–11: Inner fan removal	6–25
Figure 6–12: Hard disk drive removal	6–27
Figure 6–13: Floppy disk drive removal	6–29
Figure 6–14: A12 IF gain and A13 IF A/D boards removal	6–31
Figure 6–15: Down-converter unit 1 removal	6–33
Figure 6–16: Down-converter unit 2 removal (bottom view)	6–35
Figure 6–17: A72 DC Power-3 board removal	6–37
Figure 6–18: Standby power supply removal	6–38
Figure 6–19: AC line filter removal	6–39
Figure 6–20: Power supply modules removal	6–41
Figure 6–21: Power supply unit removal	6–43
Figure 6–22: CPU, GPIB, and Video boards removal	6–45
Figure 6–23: A20 DDC, A22 Wide ADC, A30 FFT, and A40 Memory boards removal	6–49
Figure 6–24: Mother board removal	6–51
Figure 6–25: Front panel assembly removal	6–53
Figure 6–26: Display unit removal	6–55
Figure 6–27: Left front-panel assembly removal	6–56

Figure 6–28: Right front-panel assembly removal	6–58
Figure 6–29: Rear chassis modules removal	6–61
Figure 6–30: Troubleshooting procedure 1 — Power supply system .	6–65
Figure 6–31: Troubleshooting procedure 2 — Signal processing system	6–69
Figure 6–32: Troubleshooting procedure 3 — Display system	6–77
Figure 6–33: Location of the A70 and A71 DC power supply-1 and -2 boards	6–79
Figure 6–34: Location of the A72 DC power supply-3 boards	6–80
Figure 6–35: Location of A12 IF gain board and A13 IF A/D board .	6–81
Figure 6–36: Location of the down converter unit-1	6–82
Figure 6–37: Location of the down converter unit-2	6–83
Figure 6–38: Location of the A20 DDC board	6–84
Figure 6–39: Location of the A22 Wide ADC board	6–85
Figure 6–40: Location of the A40 Memory board	6–86
Figure 9–1: Block diagram	9–3
Figure 9–2: Interconnect diagram	9–5
Figure 10–1: External modules	10–5
Figure 10–2: Front-panel assembly	10–7
Figure 10–3: Front panel (left and right)	10–9
Figure 10–4: Inner chassis modules – 1	10–11
Figure 10–5: Inner chassis modules – 2	10–13
Figure 10–6: Power supply modules	10–15
Figure 10–7: Mother board and its daughter boards	10–17
Figure 10–8: Rear panel assembly	10–19

List of Tables

Table 1–1: Warranted characteristics — Frequency	1–6
Table 1–2: Warranted characteristics — Spectrum purity	1–6
Table 1–3: Warranted characteristics — Input	1–6
Table 1–4: Warranted characteristics — Reference level	1–7
Table 1–5: Warranted characteristics — Dynamic range	1–7
Table 1–6: Warranted characteristics — Acquisition	1–7
Table 1–7: Warranted characteristics — Digital demodulation	1–8
Table 1–8: Warranted characteristics — Trigger	1–8
Table 1–9: Warranted characteristics — Installation requirements .	1–8
Table 1–10: Warranted characteristics — Environmental	1–9
Table 1–11: Typical characteristics — Dynamic range	1–10
Table 1–12: Typical characteristics — Spurious response	1–10
Table 1–13: Typical characteristics — Digital demodulation	1–11
Table 1–14: Typical characteristics — Analog demodulation	1–11
Table 1–15: Nominal traits — Frequency	1–12
Table 1–16: Nominal traits — Input	1–12
Table 1–17: Nominal traits — Reference level	1–12
Table 1–18: Nominal traits — Acquisition	1–13
Table 1–19: Nominal traits — Sampling rate	1–13
Table 1–20: Nominal traits — Minimum frame update time	1–14
Table 1–21: Nominal traits — Digital demodulation	1–16
Table 1–22: Nominal traits — Resolution bandwidth filter	1–16
Table 1–23: Nominal traits — Trigger	1–17
Table 1–24: Nominal traits — Display format	1–17
Table 1–25: Nominal traits — View	1–18
Table 1–26: Nominal traits — Marker	1–18
Table 1–27: Nominal traits — Zoom	1–18
Table 1–28: Nominal traits — Controller	1–19
Table 1–29: Nominal traits — AC power	1–19
Table 1–30: Nominal traits — Mechanical	1–19
Table 1–31: Certifications and compliances	1–20
Table 2–1: Power-cord conductor identification	2–1
Table 2–2: Power cord identification	2–2

Table 4–1: Initial test process	4–4
Table 4–2: Internal diagnostic program	4–9
Table 4–3: Test equipment	4–13
Table 4–4: Baseband tests	4–15
Table 4–5: RF tests	4–16
Table 4–6: Baseband tests	4–19
Table 4–7: RF tests — Test A	4–22
Table 4–8: RF tests — Test B	4–24
Table 4–9: RF tests — Test C	4–26
Table 4–10: RF tests — Test D	4–28
Table 4–11: RF tests — Test E	4–30
Table 4–12: RF tests — Test F	4–32
Table 4–13: Manual tests	4–34
Table 4–14: The instrument settings in the baseband	4–45
Table 4–15: The instrument settings in the RF band	4–47
Table 5–1: Adjustments	5–1
Table 5–2: Test equipment	5–2
Table 5–3: Auto calibration	5–13
Table 6–1: Relative susceptibility to static-discharge damage	6–3
Table 6–2: External inspection check list	6–5
Table 6–3: Internal inspection check list	6–6
Table 6–4: Summary of procedures	6–10
Table 6–5: Tools required for module removal	6–11
Table 6–6: Normal supply voltages	6–78
Table 6–7: Symptoms and faulty modules	6–87
Table 7–1: Options	7–1
Table 7–2: Standard accessories	7–2
Table 7–3: Optional accessories	7–2

General Safety Summary

Review the following safety precautions to avoid injury and prevent damage to this product or any products connected to it. To avoid potential hazards, use this product only as specified.

Only qualified personnel should perform service procedures.

To Avoid Fire or Personal Injury

Use Proper Power Cord. Use only the power cord specified for this product and certified for the country of use.

Ground the Product. This product is grounded through the grounding conductor of the power cord. To avoid electric shock, the grounding conductor must be connected to earth ground. Before making connections to the input or output terminals of the product, ensure that the product is properly grounded.

Observe All Terminal Ratings. To avoid fire or shock hazard, observe all ratings and markings on the product. Consult the product manual for further ratings information before making connections to the product.

Do Not Operate Without Covers. Do not operate this product with covers or panels removed.

Avoid Exposed Circuitry. Do not touch exposed connections and components when power is present.

Do Not Operate With Suspected Failures. If you suspect there is damage to this product, have it inspected by qualified service personnel.

Do Not Operate in Wet/Damp Conditions.

Do Not Operate in an Explosive Atmosphere.

Provide Proper Ventilation. Refer to the manual's installation instructions for details on installing the product so it has proper ventilation.

Symbols and Terms

Terms in this Manual. These terms may appear in this manual:



WARNING. Warning statements identify conditions or practices that could result in injury or loss of life.



CAUTION. Caution statements identify conditions or practices that could result in damage to this product or other property.

Terms on the Product. These terms may appear on the product:

DANGER indicates an injury hazard immediately accessible as you read the marking.

WARNING indicates an injury hazard not immediately accessible as you read the marking.

CAUTION indicates a hazard to property including the product.

Symbols on the Product. The following symbols may appear on the product:



WARNING
High Voltage



Protective Ground
(Earth) Terminal



CAUTION
Refer to Manual

Service Safety Summary

Only qualified personnel should perform service procedures. Read this *Service Safety Summary* and the *General Safety Summary* before performing any service procedures.

Do Not Service Alone. Do not perform internal service or adjustments of this product unless another person capable of rendering first aid and resuscitation is present.

Disconnect Power. To avoid electric shock, switch off the instrument power, and then disconnect the power cord from the mains power.

Use Care When Servicing With Power On. Dangerous voltages or currents may exist in this product. Disconnect power, remove battery (if applicable), and disconnect test leads before removing protective panels, soldering, or replacing components.

To avoid electric shock, do not touch exposed connections.

Preface

This is the service manual for the WCA330 and WCA380 Wireless Communication Analyzers. The manual contains information needed to service the analyzer to the module level.

Manual Structure

This manual is divided into sections, such as *Specifications* and *Theory of Operation*. Further, some sections are divided into subsections, such as *Product Description* and *Removal and Installation Procedures*.

Sections containing procedures also contain introductions to those procedures. Be sure to read these introductions because they provide information needed to do the service correctly and efficiently. The manual section name and a brief description of each is given below.

- *Specifications* contains a description of the analyzer and the applicable characteristics.
- *Operating Information* includes general information and operating instructions.
- *Theory of Operation* contains circuit descriptions that support service to the module level.
- *Performance Verification* contains procedures for confirming that the analyzer functions properly and meets warranted limits.
- *Adjustment Procedures* contains procedures for adjusting the analyzer to meet warranted limits.
- *Maintenance* contains information and procedures for performing preventive and corrective maintenance of the analyzer. These instructions include cleaning, module removal and installation, and fault isolation to the module.
- *Options* contains information on servicing factory-installed options.
- *Electrical Parts List* contains a statement referring you to *Mechanical Parts List*, where both electrical and mechanical modules are listed.
- *Diagrams* contains a block diagram and an interconnection diagram.
- *Mechanical Parts List* includes a table of all replaceable modules, their descriptions, and their Tektronix part numbers.

Manual Conventions

This manual uses certain conventions that you should become familiar with.

Some sections of the manual contain procedures for you to perform. To keep those instructions clear and consistent, this manual uses the following conventions:

- Names of front panel controls and menus appear in the same case (initial capitals, all uppercase, etc.) in the manual as is used on the analyzer front panel and menus. Front panel names are all upper-case letters; for example, SETUP, CONFIG, VIEW etc.
- Instruction steps are numbered unless there is only one step.

Modules

Throughout this manual, any replaceable component, assembly, or part of the analyzer is referred to generically as a module. In general, a module is an assembly (like a circuit board), rather than a component (like a resistor or an integrated circuit). Sometimes a single component is a module; for example, the chassis of the analyzer is a module.

Safety

Symbols and terms related to safety appear in the *Safety Summary* near the beginning of this manual.

Finding Other Information

Other documentation for the WCA330 and WCA380 analyzers includes:

- The *WCA330 and WCA380 User Manual* contains a tutorial to quickly describe how to operate the analyzer. It also includes an in-depth discussion on how to more completely use the analyzer features.
- The *WCA330 and WCA380 Programmer Manual* explains how to use the GPIB and LAN interfaces to remotely control the analyzer.

Contacting Tektronix

Phone	1-800-833-9200*
Address	Tektronix, Inc. Department or name (if known) 14200 SW Karl Braun Drive P.O. Box 500 Beaverton, OR 97077 USA
Web site	www.tektronix.com
Sales support	1-800-833-9200, select option 1*
Service support	1-800-833-9200, select option 2*
Technical support	Email: techsupport@tektronix.com 1-800-833-9200, select option 3* 1-503-627-2400 6:00 a.m. – 5:00 p.m. Pacific time

* **This phone number is toll free in North America. After office hours, please leave a voice mail message. Outside North America, contact a Tektronix sales office or distributor; see the Tektronix web site for a list of offices.**

Introduction

This manual contains information needed to properly service the WCA330 and WCA380 Wireless Communication Analyzers as well as general information critical to safe and effective servicing.

To prevent personal injury or damage to the analyzer, consider the following before attempting service:

- The procedures in this manual should be performed only by a qualified service person.
- Read the *General Safety Summary* and the *Service Safety Summary*, beginning on page xi.
- Read *Preparation for Use* in section 2, *Operating Information*.

When using this manual for servicing, be sure to follow all warnings, cautions, and notes.

Performance Check Interval

Generally, the performance check described in section 4, *Performance Verification*, should be done every 12 months. In addition, performance check is recommended after module replacement.

If the analyzer does not meet performance criteria, repair is necessary.

Strategy for Servicing

Throughout this manual, the term “module” refers to any field-replaceable component, assembly, or part of the analyzer.

This manual contains all the information needed for periodic maintenance of the analyzer (Examples of such information are procedures for checking performance.)

Further, it contains all information for corrective maintenance down to the module level. To isolate a failure to a module, use the fault isolation procedures found in *Troubleshooting*, part of section 6, *Maintenance*. To remove and replace any failed module, follow the instructions in *Removal and Installation Procedures*, also part of section 6. After isolating a faulty module, replace it with a fully-tested module obtained from the factory. Section 10, *Mechanical Parts List*, contains part number and ordering information for all replaceable modules.

Specifications

Product Overview

WCA330 and WCA380 are wireless communication analyzers equipped with a 3 GHz/8 GHz down-converter to analyze Radio Frequency (RF) signals. The newly adopted architecture allows concurrent acquisition of time and frequency domain data and display of measurement results in color. The analyzer provides a wide variety of functions such as spectrum, power, analog and digital modulation, and CDMA analyses. The instrument is shown in Figure 1-1.

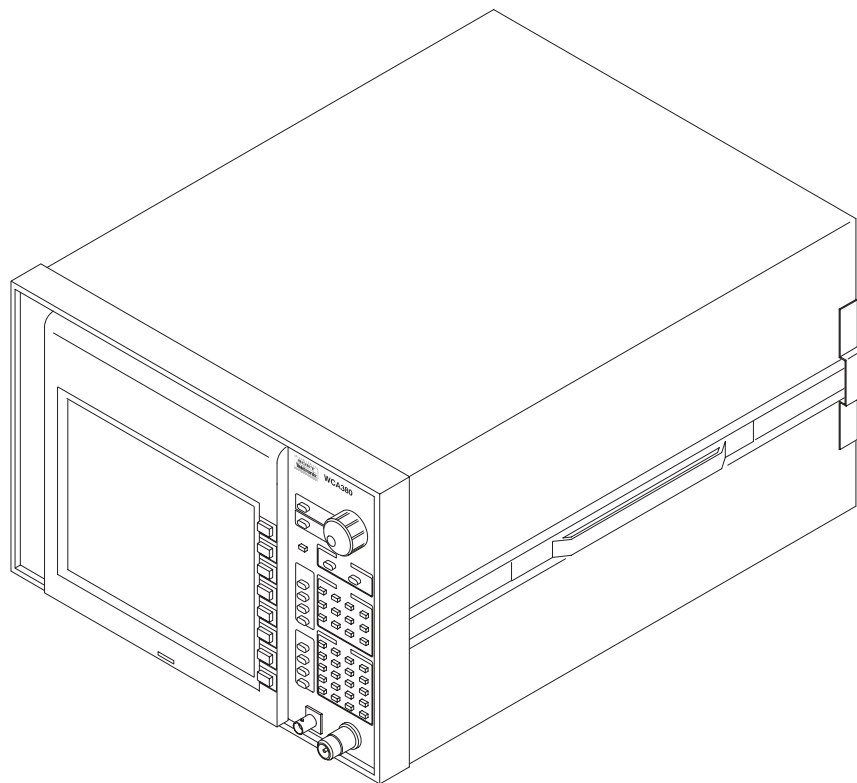


Figure 1-1: WCA330/WCA380 wireless communication analyzer

Features

- Measurement frequency range: DC to 3 GHz (WCA330)/8 GHz (WCA380)
- Measurement span: 100 Hz to 3 GHz
- Simultaneous processing of real-time frequency and modulation analyses
- Digital zoom function (2 to 1000-times expansion of frequency)
- Simultaneous analysis and display of frequency and time domain data
- Abundant trigger functions: frequency mask, level, and external triggers
- Power analysis: noise, power, C/N, C/No, ACP, and OBW
- Digital modulated signal analysis (Maximum span of 30 MHz)
- CDMA analysis (IS-95 standard)
- Ability to display 17 types of analysis results:
 - Spectrum display (frequency vs. level or phase)
 - Spectrogram display (frequency vs. level, or phase vs. time)
 - Waterfall display (time vs. modulation factor, phase or frequency)
 - Analog demodulation display
(time vs. modulation factor, phase or frequency)
 - FSK demodulation view (time vs. frequency)
 - Constellation/vector display (digital demodulation)
 - EYE diagram display
 - Symbol table display
 - EVM/Rho analysis display (IS-95 standard)
 - Spurious analysis display (IS-95 standard)
 - Time characteristics analysis display (IS-95 standard)
 - Code domain power (W-CDMA standard)
 - Time vs. channel power (W-CDMA standard)
 - Code domain power spectrum (W-CDMA standard)
 - ACP measurement (W-CDMA standard)
 - CCDF display
 - CCDF measurement display
- 12.1 inch, full-color TFT display

Targets

The analyzer is capable of real-time analysis for the following purposes:

- Power measurement: Power, noise, C/N, ACP, and OBW
- W-CDMA (3GPP): Code domain power, EVM, and ACP
- CDMA (IS-95): Rho, spurious characteristics, and time characteristics
- CCDF measurement
- Digital modulation analysis
- Analog modulation analysis
- Variation analysis in PLL frequency:
 - Jitter in reference oscillator of a mobile phone
 - localization of a radio set
 - Hard disk read-out jitter
- Analysis of momentary noise:
 - Mixed noise measurement
 - EMI measurement
- Multi-path measurement: Measurement of electric wave environment
- Electric wave interference: Radar interference
- Electric wave analysis: Analyzing electric wave from foreign countries

Difference between WCA330 and WCA380

WCA330 and WCA380 have the same functions except for their measurement frequency ranges:

WCA330 DC to 3 GHz

WCA380 DC to 8 GHz

Unless otherwise noted, descriptions in this manual apply to both.

Specifications

The specifications are organized into sub-sections: *Warranted Characteristics*, *Typical Characteristics*, *Nominal Traits*, and *Certifications and Compliances*.

Warranted Characteristics

This section lists the various *warranted characteristics* that describe the analyzer. Electrical and environmental characteristics are also included.

Warranted characteristics are described in terms of quantifiable performance limits which are warranted.

As stated above, this section lists only warranted characteristics. A list of *typical characteristics* starts on page 1–10.

Performance Conditions

The performance limits in this specification are valid with these conditions:

- The analyzer must have been calibrated/adjusted at an ambient temperature between +20° C and +30° C.
- The analyzer must be in an environment with temperature, altitude, humidity, and vibration within the operating limits described in these specifications.
- The analyzer must have had a warm-up period of at least 20 minutes.
- The analyzer must be operating at an ambient temperature between +10° C and +40° C.

Table 1-1: Warranted characteristics — Frequency

Characteristic	Description	PV ref. page
Frequency range	Baseband DC to 10 MHz RF1 band 10 MHz to 3 GHz RF2 band 2.5 GHz to 3.5 GHz (WCA380) RF3 band 3.5 GHz to 6.5 GHz (WCA380) RF4 band 5.0 GHz to 8.0 GHz (WCA380) I/Q input DC to 16 MHz	
Center frequency setting resolution	0.1 Hz	4-36
Residual FM	2 Hz p-p	
Reference frequency		
Aging per day	1×10^{-9} (after 30 days of operation)	
Aging per year	1×10^{-7} (after 30 days of operation)	
Temperature drift	1×10^{-7} (10° C to 40° C)	
Total frequency error	2×10^{-7} (within one year after calibration)	4-35
Reference output level	>0 dBm	

Table 1-2: Warranted characteristics — Spectrum purity

Characteristic	Description	PV ref. page
Spectrum purity	Frequency = 1500 MHz, RF attenuation = 0 dB	4-38
Carrier offset = 10 kHz	100 dBc/Hz (Normal IF mode) 95 dBc/Hz (HiRes IF mode)	
Carrier offset = 100 kHz	103 dBc/Hz (Normal IF mode) 105 dBc/Hz (HiRes IF mode)	
Carrier offset = 1 MHz	120 dBc/Hz (Normal IF mode) 125 dBc/Hz (HiRes IF mode)	

Table 1-3: Warranted characteristics — Input

Characteristic	Description	PV ref. page
VSWR	<1.5 (2.5 GHz, RF attenuator ≥10 dB) <2.0 (7.5 GHz, RF attenuator ≥10 dB, WCA380)	

Table 1-4: Warranted characteristics — Reference level

Characteristic	Description	PV ref. page
Reference level accuracy		
at 20° C to 30° C	±0.8 dB (Baseband) ±1.5 dB (RF1) ±1.5 dB (RF2, WCA380) ±2.0 dB (RF3, WCA380) ±2.0 dB (RF4, WCA380)	4-42
at 10° C to 40° C	±1.0 dB (Baseband) ±2.0 dB (RF1) ±2.0 dB (RF2, WCA380) ±2.5 dB (RF3, WCA380) ±2.5 dB (RF4, WCA380)	
Level linearity	±0.2 dB (0 to -40 dBfs)	

Table 1-5: Warranted characteristics — Dynamic range

Characteristic	Description	PV ref. page
1 dB compression input	+2 dBm (RF attenuation = 0 dB)	
3 rd order intermodulation distortion	73 dBc (Hires IF mode, signal level ≤10 dBfs, 2 GHz) 70 dBc (Normal IF mode, signal level ≤10 dBfs, 2 GHz) 55 dBc (Wide IF mode, signal level ≤10 dBfs, 2 GHz)	4-30
Spectrum		
due to modulation for GSM	80 dBc (30 kHz RBW, 1.2 MHz offset) 78 dBc (100 kHz RBW, 1.8 MHz offset)	
due to switching transient for GSM	78 dBc (30 kHz RBW, 1.2 MHz offset) 78 dBc (30 kHz RBW, 1.8 MHz offset)	
ACPR (W-CDMA forward link, Crest factor = 11 dB)	65 dB (ACPR configuration)	

Table 1-6: Warranted characteristics — Acquisition

Characteristic	Description
Block size	1 to 16,000 frames (Frequency mode, 256 points) 1 to 4,000 frames (Frequency mode, 1024 points) 1 to 2,000 frames (Dual or Zoom mode)
Real-time span	5 MHz
Vector span	30 MHz (Wide IF mode, IQ) 10 MHz (Baseband) 6 MHz (Normal IF mode) 5 MHz (Hires IF mode)

Table 1-7: Warranted characteristics — Digital demodulation

Characteristic	Description	PV ref. page
Error measurement accuracy		4-51
PDC (100 kHz span)	EVM \leq 1.2 %, Mag error \leq 1.0 %, Phase error \leq 0.8°	
PHS (1 MHz span)	EVM \leq 1.4 %, Mag error \leq 1.2 %, Phase error \leq 0.8°	
GSM (1 MHz span)	EVM \leq 1.8 %, Mag error \leq 1.2 %, Phase error \leq 1.0°	

Table 1-8: Warranted characteristics — Trigger

Characteristic	Description	PV ref. page
Frequency event trigger		4-19
Mask resolution	1 bin	
Level range	0 to -70 dBfs	
Time event trigger		4-19
Mask resolution	1 sample point	
Level range	0 to -40 dBfs	
External trigger threshold level	1.6 V	4-19
External synchronization timing uncertainty	\pm 50 ns (20 MHz and 30 MHz span in Wide IF mode) \pm 100 ns (10 MHz span in Wide IF mode)	

Table 1-9: Warranted characteristics — Installation requirements

Characteristic	Description
Heat dissipation	
Maximum power consumption	350 W
Maximum line current	5 Arms at 50 Hz, 90 V line, with 5 % clipping.
Surge current	Maximum 30 A peak at 25° C for \leq 5 line cycles, after product has been turned off for at least 30 s.
Clearance	
Bottom	20 mm (0.79 in)
Both sides	50 mm (1.97 in)
Rear	50 mm (1.97 in) from rear fan cover

Table 1-10: Warranted characteristics — Environmental

Characteristic	Description
Temperature	
Operating	+10° C to +40° C
Non-operating	-20° C to +60° C
Humidity	
Operating and non-operating	20 % to 80 % (no condensation); Maximum wet-bulb temperature 29° C
Altitude	
Operating	To 3,000 m (10,000 ft)
Non-operating	To 12,000 m (40,000 ft)
Vibration	
Operating	2.65 m/s ² rms (0.27 Grms), 5 to 500 Hz
Non-operating	22.3 m/s ² rms (2.28 Grms), 5 to 500 Hz
Shock	
Non-operating	196 m/s ² rms (20 G), half-sine, 11 ms duration. Three shocks per axis in each direction (18 shocks total)

Typical Characteristics

This subsection contains tables that list the various *typical characteristics* which describe the WCA330 and WCA380 Wireless Communication Analyzers.

Typical characteristics are described in terms of typical or average performance. Typical characteristics are not warranted.

Table 1-11: Typical characteristics — Dynamic range

Characteristic	Description
Displayed average noise level	
Baseband	-153 dBm/Hz (1 to 10 MHz)
Hires IF mode	-150 dBm/Hz (10 to 25 MHz) -147 dBm/Hz (25 M to 2.5 GHz) -145 dBm/Hz (2.5 to 3 GHz) -142 dBm/Hz (3 to 8 GHz, WCA380)
Normal IF mode	-147 dBm/Hz (10 to 25 MHz) -143 dBm/Hz (25 M to 2.5 GHz) -141 dBm/Hz (2.5 to 3 GHz) -140 dBm/Hz (3 to 8 GHz, WCA380)
Wide IF mode	-140 dBm/Hz (50 M to 3 GHz) -140 dBm/Hz (3 to 8 GHz)

Table 1-12: Typical characteristics — Spurious response

Characteristic	Description
Image suppression	
1 st IF	75 dB (RF1, center 1.5 GHz, input 9.962 GHz) 75 dB (RF2, center 3 GHz, input 11.462 GHz, WCA380) 70 dB (RF3, center 5 GHz, input 5.842 GHz, WCA380) 70 dB (RF4, center 6.5 GHz, input 5.658 GHz, WCA380)
2 nd and 3 rd IF	80 dB (RF1, Normal/Hires IF) 75 dB (RF2, RF3, RF4, Normal or Hires IF mode, WCA380) 60 dB (RF1, Wide IF mode) 53 dB (RF2, RF3, RF4, Wide IF mode, WCA380)
Alias suppression	65 dB (Baseband) 60 dB (IQ)
Residual response	
without signal, span ≤5 MHz, RBW = 30 kHz, averaged	-73 dBfs or -93 dBm whichever greater (Normal or Hires IF mode) -73 dBfs or -93 dBm whichever greater (Baseband, >1 MHz)
Wide IF mode without signal, RBW = 100kHz, averaged	-55 dBfs or -85 dBm whichever greater (within 10 minutes and ±5° C from acquisition start)

Table 1-12: Typical characteristics — Spurious response (Cont.)

Characteristic	Description
Spurious response	
signal at center, 2 MHz span, averaged, Normal and Hires IF modes	-70 dBc or -75 dBfs whichever greater (offset > 400 kHz) -65 dBc or -70 dBfs whichever greater (50 kHz ≤ offset ≤ 400 kHz)
signal at center, 10 MHz span, averaged, Wide IF mode	-60 dBc or -65 dBfs whichever greater (offset > 400 kHz)
Sideband spurious due to I/Q imbalance (averaged)	-55 dBc (Wide IF) -60 dBc (Wide IF, within 1 hour and ±5° C from self IQ balance calibration)

Table 1-13: Typical characteristics — Digital demodulation

Characteristic	Description
Error measurement accuracy	
64 QAM, 5.3 Msps, 1 GHz carrier	EVM ≤ 2.5 % (20 MHz span)
QPSK, 4.096 Msps, 2 GHz carrier	EVM ≤ 2.5 % (20 MHz span)
QPSK, 16.384 Msps, 2 GHz carrier	EVM ≤ 3.0 % (30 MHz span, 25° C ± 5° C)

Table 1-14: Typical characteristics — Analog demodulation

Characteristic	Description
Demodulation accuracy	
AM demodulation	± 2 % (-10 dBfs Input at center, 10 to 60 % modulation depth)
PM demodulation	± 3° (-10 dBfs Input at center)
FM demodulation	± 1 % of span (-10 dBfs Input at center)

Nominal Traits

This section contains a collection of tables that list the various *nominal traits* that describe the WCA330 and WCA380 Wireless Communication Analyzers. Electrical and mechanical traits are included.

Nominal traits are described using simple statements of fact such as “Four, all identical” for the trait “Output Channels, Number of,” rather than in terms of limits that are performance requirements.

Table 1-15: Nominal traits — Frequency

Characteristic	Description
Reference frequency	
External reference input	10 MHz, -10 to +6 dBm

Table 1-16: Nominal traits — Input

Characteristic	Description
Signal Input	
Input connector	N type (except IQ input); BNC type (IQ input)
Input impedance	50 Ω
Maximum input level	
Maximum DC voltage	0 V (RF band); ± 5 V (Baseband); ± 5 V (IQ input)
Maximum input power	+30 dBm (RF band)
Input attenuator	
RF attenuator	0 to 50 dB in 10 dB steps; 0 dB, 2 dB, 5 dB, 7 dB (RF1 and RF2 (WCA380))
Baseband attenuator	0 to 40 dB in 1 dB steps
I/Q Attenuator	0 to 30 dB in 10 dB steps

Table 1-17: Nominal traits — Reference level

Characteristic	Description
Reference level setting	-50 to +30 dBm in 1 dB steps (RF) -30 to +30 dBm in 1 dB steps (Baseband) -10 to +20 dBm in 10 dB steps (IQ)

Table 1-18: Nominal traits — Acquisition

Characteristic	Description
Acquisition mode	Roll (one frame data is continuous.) Block (data within acquired block is continuous.)
Acquisition memory size	16 Mbytes
Memory configuration mode	Frequency (all memory is used for frequency data.) Dual (memory is shared with time and frequency data.) Zoom (memory is shared with time, frequency, and zoomed data.)
Data samples in one frame	256 points (Frequency mode only); 1024 points (all modes)
A/D converter	14 bits, 25.6 Msps (Baseband, Normal IF and Hires IF modes) 12 bits, 40.96 Msps \times 2 for I and Q each signal (IQ, Wide IF mode)

Table 1-19: Nominal traits — Sampling rate

Characteristic	Description
Sampling rate: Baseband, Normal and Hires IF modes	
10 MHz span (Baseband)	12.8 Msps
6 MHz span (Normal, RF)	12.8 Msps
5 MHz span	6.4 Msps
2 MHz span	3.2 Msps
1 MHz span	1.6 Msps
500 kHz span	800 ksps
200 kHz span	320 ksps
100 kHz span	160 ksps
50 kHz span	80 ksps
20 kHz span	32 ksps
10 kHz span	16 ksps
5 kHz span	8 ksps
2 kHz span	3.2 ksps
1 kHz span	1.6 ksps
500 Hz span	800 sps
200 Hz span	320 sps
100 Hz span	160 sps
Sampling Rate: IQ, Wide IF mode	
20 M to 30 MHz span	40.96 Msps
10 MHz	20.48 Msps

Table 1-20: Nominal traits — Minimum frame update time

Characteristic	Description
Minimum frame update time: Frequency data acquisition	
10 MHz span (Baseband)	80 μ s (1024 points)
500 k to 6 MHz span	20 μ s (256 points, \leq 5 MHz); 80 μ s (1024 points)
50 k to 200 kHz span	200 μ s
5 k to 20 kHz span	2 ms
500 to 2 kHz span	20 ms
200 Hz span	50 ms
100 Hz span	100 ms
Minimum frame update time: Dual data acquisition	
500 k to 6 MHz span	160 μ s
50 k to 500 kHz span	400 μ s
5 k to 20 kHz span	4 ms
500 to 2 kHz span	40 ms
200 Hz span	100 ms
100 Hz span	200 ms

Table 1-20: Nominal traits — Frame update time

Characteristic	Description
Frame update time: Zoom data acquisition, Baseband, Normal IF, Hires IF	
5 MHz span	160 μ s
2 MHz span	320 μ s
1 MHz span	640 μ s
500 kHz span	1.28 ms
200 kHz span	3.2 ms
100 kHz span	6.4 ms
50 kHz span	12.8 ms
20 kHz span	32 ms
10 kHz span	64 ms
5 kHz span	128 ms
2 kHz span	320 ms
1 kHz span	640 ms
500 Hz span	1.28 s
200 Hz span	3.2 s
100 Hz span	6.4 s
Frame update time: Zoom data acquisition, Wide IF, IQ	
30 MHz span	25 μ s
20 MHz span	25 μ s
10 MHz span	50 μ s

Table 1-21: Nominal traits — Digital demodulation

Characteristic	Description
Demodulator	
Carrier type	Continuous, Burst
Modulation format	BPSK, QPSK, $\pi/4$ Shift DQPSK, 8 PSK, OQPSK, 16 QAM, 64 QAM, 256 QAM, GMSK
Measurement filter	Root cosine
Reference filter	Cosine, Gauss
Filter parameter	α /BT: 0.0001 to 1 in 0.0001 steps
Maximum symbol rate	5.3 Msps (Normal and HiRes IF modes, Baseband); 20.48 Msps (Wide IF mode, IQ)
Standard setup	PDC, PHS, NADC, TETRA, GSM, CDPD, IS-95, T-53
Display format	
Vector diagram	Symbol/locus display, Frequency error measurement, Origin offset measurement
Constellation diagram	Symbol display, Frequency error measurement, Origin offset measurement
Eye diagram	I/Q/Trellis display (1 to 16 symbols)
Error vector diagram	EVM, Magnitude error, Phase error, Waveform quality (\odot) measurement
Symbol table	Binary, Octal, Hexadecimal

Table 1-22: Nominal traits — Resolution bandwidth filter

Characteristic	Description
Filter shape	Gaussian, Rectangle, Root Nyquist
Range	1 Hz to 10 MHz
Maximum span setting to activate RBW filter	50 MHz

Table 1-23: Nominal traits — Trigger

Characteristic	Description
Trigger Mode	
Normal IF mode, span ≤ 6 MHz Hires IF mode, span ≤ 5 MHz Baseband	Auto (triggered by block acquisition) Normal (triggered by event) Quick (triggered by event, quick re-triggerable) Delayed (triggered by event with specified delay) Interval (triggered by interval timer) Quick Interval (triggered by quick re-triggerable timer) Timeout (triggered when event is not appeared within timer setting)
IQ, Wide IF mode	Auto (triggered by block acquisition) Normal (triggered by event)
Trigger event source	Internal (level comparator); External (TTL)
Internal trigger comparator data source	Frequency amplitude, Time amplitude
Pre/Post trigger setting	Trigger position is settable within 0 % to 100 % of total data length.

Table 1-24: Nominal traits — Display format

Characteristic	Description
Waveform	Frequency vs. Amplitude/Phase Frequency vs. I/Q voltage Time vs. Amplitude/Phase Time vs. I/Q voltage
Spectrogram, Waterfall	Time vs. Frequency vs. Amplitude/Phase Time vs. Frequency vs. I/Q voltage Time vs. Amplitude/Phase Multi-frame Time vs. I/Q voltage Multi-frame
AM demodulation	Time vs. Modulation depth
FM demodulation	Time vs. Frequency deviation
PM demodulation	Time vs. Phase deviation
FSK demodulation	Time vs Frequency deviation
Polar	Vector diagram, Constellation diagram
Eye pattern	I eye pattern, Q eye pattern, Trellis
Symbol table	Binary, Octal, Hexadecimal
Error vector	EVM, Magnitude error, Phase error, Waveform quality (Q)

Table 1-25: Nominal traits — View

Characteristic	Description
Number of views	1, 2, 4
Settable views	8 maximum
Display traces	2 on Waveform display
LCD	
Size	12.1 inch
Display resolution	1024 x 768 pixels
Color	256 colors maximum

Table 1-26: Nominal traits — Marker

Characteristic	Description
Marker type	Normal, Delta, Band power
Search function	Peak right, Peak left, Maximum
Link between views	On/Off
Measurement function	Noise power, Power within band, C/N, Adjacent channel power, Occupied bandwidth

Table 1-27: Nominal traits — Zoom

Characteristic	Description
Digital zoom ratio	2 to 1000
Maximum span in the Zoom mode	5 MHz (Baseband, Normal and Hires IF modes); 30 MHz (IQ, Wide IF mode)

Table 1-28: Nominal traits — Controller

Characteristic	Description
CPU	Intel Celeron 433 MHz
DRAM	128 Mbyte DIMM
OS	Windows 98
System bus	PCI, ISA
Data storage	
Hard disk	10 Gbyte 3.5 inch EIDE
Floppy disk	1.44 Mbyte 3.5 inch
Interface	
Printer	Centronics parallel
GPIB	IEEE 488.1
LAN	10/100 Base-T (IEEE 802.3)
Mouse	PS-2
Keyboard	PC/AT

Table 1-29: Nominal traits — AC power

Characteristic	Description
Input voltage	Rating voltage: 100 to 240 VAC; Voltage range: 90 to 250 VAC
Line frequency	47 to 66 Hz

Table 1-30: Nominal traits — Mechanical

Characteristic	Description
Width	430 mm (16.9 in) without belts
Height	270 mm (10.6 in) without feet
Length	600 mm (23.6 in) without connectors and fan cover
Net weight	31 kg

Certification and Compliances

The certification and compliances for the WCA330 and WCA380 Wireless Communication Analyzers are listed in Table 1–31.

Table 1–31: Certifications and compliances

Characteristic	Description																				
EC declaration of conformity – EMC	<p>EC Council Directive 89/336/EEC, amended by 93/68/EEC; EN 61326-1:1997 Product Family Standard for Electrical Equipment for Measurement, Control, and Laboratory Use EMC Requirements</p> <p>Emissions:</p> <table> <tr> <td>EN 55011</td> <td>Class A Radiated and Conducted Emissions</td> </tr> <tr> <td>EN 61000–3–2</td> <td>Power Line Harmonics</td> </tr> <tr> <td>EN 61000–3–3</td> <td>Line Voltage Alteration and Flicker</td> </tr> </table> <p>Immunity:</p> <table> <tr> <td>EN61000–4–2</td> <td>Electrostatic Discharge Immunity</td> </tr> <tr> <td>EN61000–4–3</td> <td>RF Electromagnetic Field Immunity</td> </tr> <tr> <td>EN61000–4–4</td> <td>Electrical Fast Transient/Burst Immunity</td> </tr> <tr> <td>EN61000–4–5</td> <td>Power Line Surge Immunity</td> </tr> <tr> <td>EN61000–4–6</td> <td>Conducted Disturbances Induced by RF Fields</td> </tr> <tr> <td>EN61000–4–8</td> <td>Power Frequency Electromagnetic Field</td> </tr> <tr> <td>EN61000–4–11</td> <td>Power Line Interruption Immunity</td> </tr> </table>	EN 55011	Class A Radiated and Conducted Emissions	EN 61000–3–2	Power Line Harmonics	EN 61000–3–3	Line Voltage Alteration and Flicker	EN61000–4–2	Electrostatic Discharge Immunity	EN61000–4–3	RF Electromagnetic Field Immunity	EN61000–4–4	Electrical Fast Transient/Burst Immunity	EN61000–4–5	Power Line Surge Immunity	EN61000–4–6	Conducted Disturbances Induced by RF Fields	EN61000–4–8	Power Frequency Electromagnetic Field	EN61000–4–11	Power Line Interruption Immunity
EN 55011	Class A Radiated and Conducted Emissions																				
EN 61000–3–2	Power Line Harmonics																				
EN 61000–3–3	Line Voltage Alteration and Flicker																				
EN61000–4–2	Electrostatic Discharge Immunity																				
EN61000–4–3	RF Electromagnetic Field Immunity																				
EN61000–4–4	Electrical Fast Transient/Burst Immunity																				
EN61000–4–5	Power Line Surge Immunity																				
EN61000–4–6	Conducted Disturbances Induced by RF Fields																				
EN61000–4–8	Power Frequency Electromagnetic Field																				
EN61000–4–11	Power Line Interruption Immunity																				
Australia/New Zealand declaration of conformity – EMC	<p>Complies with EMC provision of Radiocommunications Act per the following standard(s):</p> <table> <tr> <td>AS/NZS 2064.1/2</td> <td>Industrial, Scientific, and Medical Equipment: 1992</td> </tr> </table>	AS/NZS 2064.1/2	Industrial, Scientific, and Medical Equipment: 1992																		
AS/NZS 2064.1/2	Industrial, Scientific, and Medical Equipment: 1992																				
EC declaration of conformity – Low voltage	<p>Compliance was demonstrated to the following specification as listed in the Official Journal of the European Union:</p> <p>Low Voltage Directive 73/23/EEC, amended by 93/69/EEC</p> <table> <tr> <td>EN 61010-1/A2:1995</td> <td>Safety requirements for electrical equipment for measurement control and laboratory use.</td> </tr> </table>	EN 61010-1/A2:1995	Safety requirements for electrical equipment for measurement control and laboratory use.																		
EN 61010-1/A2:1995	Safety requirements for electrical equipment for measurement control and laboratory use.																				
U.S. nationally recognized testing laboratory listing	<table> <tr> <td>UL3111-1</td> <td>Standard for electrical measuring and test equipment.</td> </tr> </table>	UL3111-1	Standard for electrical measuring and test equipment.																		
UL3111-1	Standard for electrical measuring and test equipment.																				
Canadian certification	<table> <tr> <td>CAN/CSA C22.2 No.1010.1</td> <td>CSA safety requirements for electrical and electronic measuring and test equipment.</td> </tr> </table>	CAN/CSA C22.2 No.1010.1	CSA safety requirements for electrical and electronic measuring and test equipment.																		
CAN/CSA C22.2 No.1010.1	CSA safety requirements for electrical and electronic measuring and test equipment.																				
Condition of Approval	<p>Safety Certifications/Compliances are made for the following conditions:</p> <p>Altitude (maximum operation): 3,000 meters (10,000 ft)</p>																				

Table 1-31: Certifications and compliances (Cont.)

Characteristic	Description
Installation (overvoltage) category	<p>Terminals on this product may have different installation (overvoltage) category designations. The installation categories are:</p> <p>CAT III Distribution-level mains (usually permanently connected). Equipment at this level is typically in a fixed industrial location.</p> <p>CAT II Local-level mains (wall sockets). Equipment at this level includes appliances, portable tools, and similar products. Equipment is usually cord-connected.</p> <p>CAT I Secondary (signal level) or battery operated circuits of electronic equipment.</p>
Pollution degree	<p>A measure of the contaminates that could occur in the environment around and within a product. Typically the internal environment inside a product is considered to be the same as the external. Products should be used only in the environment for which they are rated.</p> <p>Pollution Degree 1 No pollution or only dry, nonconductive pollution occurs. Products in this category are generally encapsulated, hermetically sealed, or located in clean rooms.</p> <p>Pollution Degree 2 Normally only dry, nonconductive pollution occurs. Occasionally a temporary conductivity that is caused by condensation must be expected. This location is a typical office/home environment. Temporary condensation occurs only when the product is out of service.</p> <p>Pollution Degree 3 Conductive pollution, or dry, nonconductive pollution that becomes conductive due to condensation. These are sheltered locations where neither temperature nor humidity is controlled. The area is protected from direct sunshine, rain, or direct wind.</p> <p>Pollution Degree 4 Pollution that generates persistent conductivity through conductive dust, rain, or snow. Typical outdoor locations.</p>
Safety certification compliance	
Equipment type	Test and measuring
Safety class	Class 1 (as defined in IEC 1010-1, Annex H) – grounded product
Overvoltage category	Overvoltage Category II (as defined in IEC 1010-1, Annex J)
Pollution degree	Pollution Degree 2 (as defined in IEC 1010-1). Note: Rated for indoor use only.

Operating Information

Installation

Supplying Operating Power



WARNING. AC POWER SOURCE AND CONNECTION. The analyzer operates from a single-phase power source. It has a three-wire power cord and two-pole, three-terminal grounding type plug. The voltage to ground (earth) from either pole of the power source must not exceed the maximum rated operating voltage, 250 volts.

Before making connection to the power source, be sure the analyzer has a suitable two-pole, three-terminal grounding-type plug.

GROUNDING. This instrument is safety Class 1 equipment (IEC designation). All accessible conductive parts are directly connected through the grounding conductor of the power cord to the grounded (earthing) contact of the power plug.



WARNING. The power input plug must be inserted only in a mating receptacle with a grounding contact where earth ground has been verified by a qualified service person. Do not defeat the grounding connection. Any interruption of the grounding connection can create an electric shock hazard.

For electric shock protection, the grounding connection must be made before making connection to the instrument's input or output terminals.

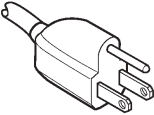
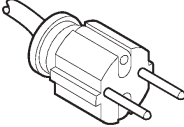
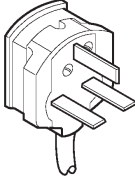
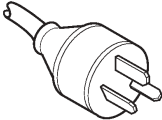
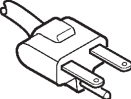
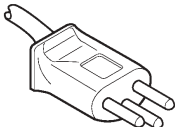
Power Cord Information

A power cord with the appropriate plug configuration is supplied with each analyzer. Table 2-1 gives the color-coding of the conductors in the power cord. If you require a power cord other than the one supplied, refer to Table 2-2, Power Cord Identification.

Table 2-1: Power-cord conductor identification

Conductor	Color	Alternate color
Ungrounded (Line)	Brown	Black
Grounded (Neutral)	Light Blue	White
Grounded (Earthing)	Green/Yellow	Green

Table 2-2: Power cord identification

Plug configuration	Normal usage	Option number
	North America 125 V	Standard
	Europe 230 V	A1
	United Kingdom 230 V	A2
	Australia 230 V	A3
	North America 230 V	A4
	Switzerland 230 V	A5

Operating Voltage

This analyzer operates with any line voltage from 85–264 VAC_{RMS} with any line frequency from 47–66 Hz. Before plugging the cord in the outlet, be sure that the power supply voltage is proper.

Operating Environment

The following environmental requirements are provided to ensure proper operation and long instrument life.

Operating Temperature

Operate the analyzer where the ambient air temperature is from +10° C to +40° C with no diskette in the floppy drive. Store the analyzer in ambient temperatures from -20° C to +60° C with no diskette in the floppy drive. After storage at temperatures outside the operating limits, allow the chassis to stabilize at a safe operating temperature before applying power.

Ventilation Requirements

The analyzer is cooled by air drawn in and exhausted by an internal fan and an external fan on the rear panel. To ensure proper cooling of the analyzer allow at least 5 cm clearance on both sides of and behind the analyzer. The feet on the bottom of the analyzer provide the required clearance when set on flat surfaces. The top of the analyzer does not require ventilation clearance.

Connecting the Power Cord

1. Plug in the power cord to the AC inlet on the rear panel. Refer to Figure 2–1.

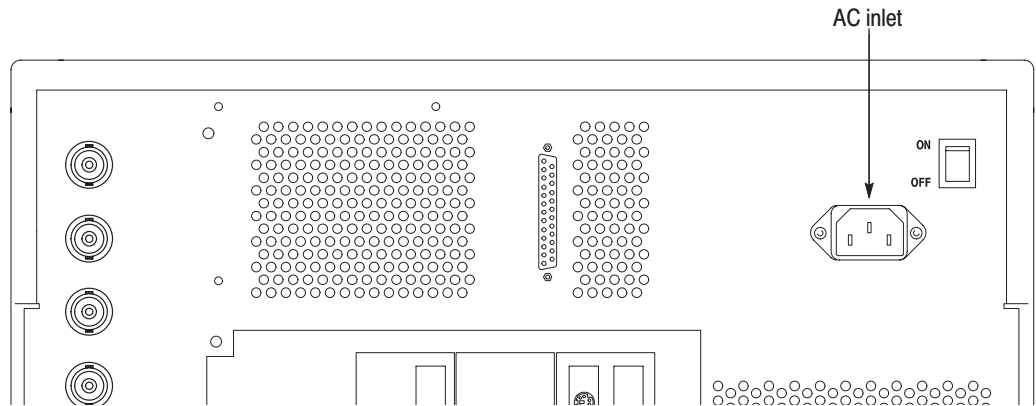


Figure 2-1: AC inlet on the rear panel



CAUTION. *The analyzer operates at a power supply voltage of 90 V to 250 V and a power supply frequency of 47 Hz to 66 Hz. Verify that your power supply is suitable for the analyzer before plugging the cord into the outlet.*

2. Plug the power cord into a three-wired grounded outlet.

The metallic section of the analyzer front panel is grounded through the power cord ground line. To prevent electrical shocks, insert the plug into an outlet that has a protective ground line.

Powering On

Connecting the Mouse

Connect the standard mouse to the rear panel connector before turning the analyzer power on (see Figure 2–2).



CAUTION. To avoid damaging the analyzer, make sure that the power is off before connecting the mouse. If the power is on, turn off the power switch on the front panel and wait until the power shuts off completely.

For the normal analyzer operation, the mouse is not necessary. You can use it in these cases:

- When you want to operate with a mouse instead of the front panel. Refer to the *User Manual* for the mouse operations.
- When Windows 98 displays a dialog box for maintaining the operating system (for example, changing the time).

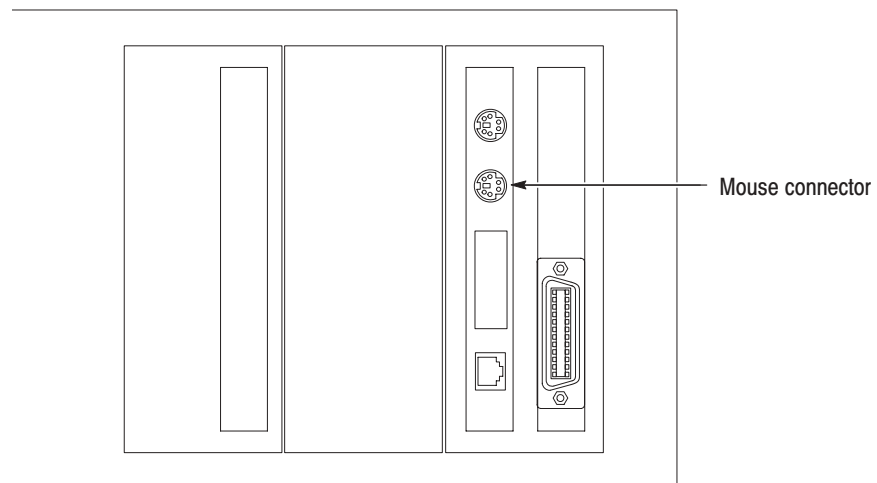


Figure 2–2: Mouse connector location (rear panel)

Turning On the Power 1. Turn on the principal power switch on the rear panel.

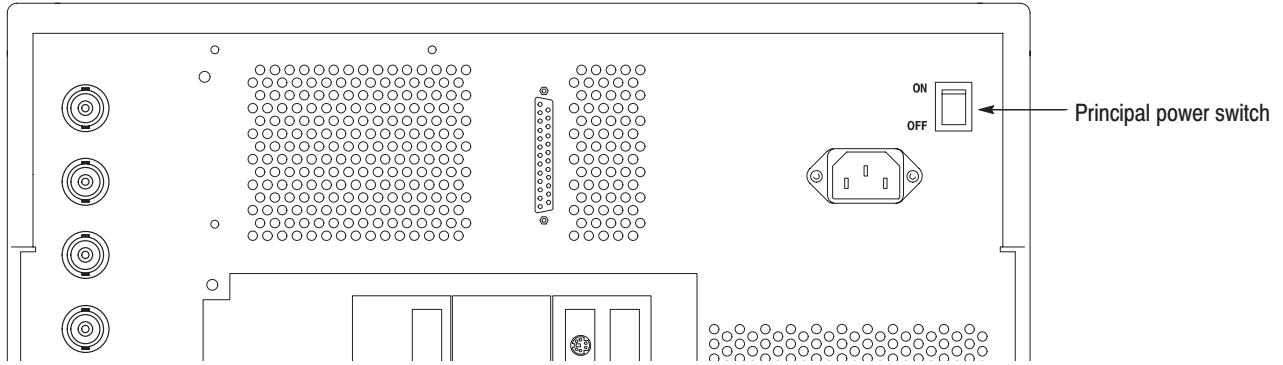


Figure 2-3: Principal power switch (rear panel)

When you turn on the principal power switch, a voltage is placed on the standby circuit in the analyzer. Make sure that the STANDBY LED is lit.

2. Turn on the switch (**ON/STANDBY**) located at the bottom left corner of the front panel.

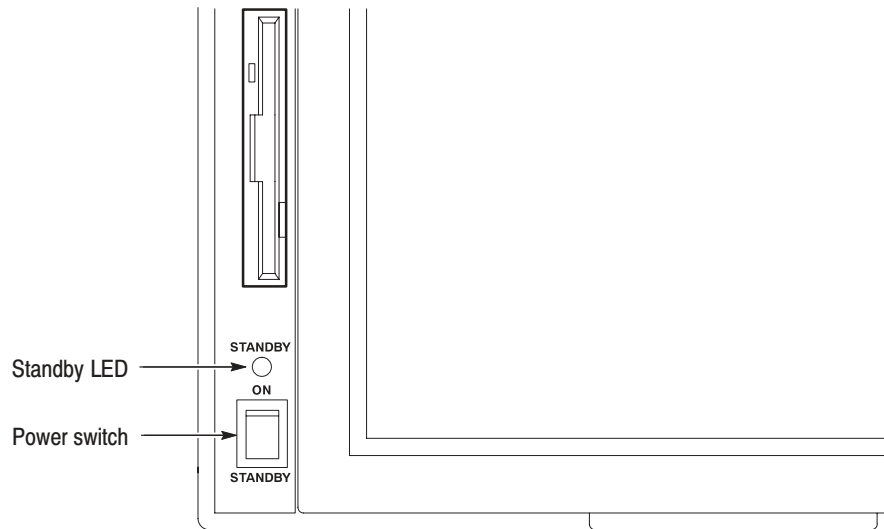


Figure 2-4: Power switch (ON/STANDBY)

When you power on the analyzer, Windows 98 is booted and then applications are started. The STANDBY LED goes out after blinking for a while.

When the New clock settings dialog box appears. If Windows 98 displays the “New clock settings” dialog box at power-on (see Figure 2–5), press the **OK** button with the mouse to start the analyzer application.



Figure 2–5: New clock settings dialog box

For the date and time setting procedure, refer to the *User Manual*.

Self Test. When you turn on the power, the analyzer performs a Pass/Fail test for ROM and RAM using an internal diagnosis routine and checks whether the A20 (Digital Down Converter) board is installed. Upon completion, it displays the result as shown in Figure 2–6.

```
WCA380 WIRELESS COMMUNICATION ANALYZER
Copyright (C) 2000 SONY/TEKTRONIX CORPORATION

Main System:
  Version:      3.11

Sub System:
  Version:      4.1
  Rom:          Pass
  Ram:          Pass
  A20:          Installed

Options:
```

Figure 2–6: Display of self test results upon power-up (upper left of screen)

The following initial screen appears, as shown in Figure 2-7.

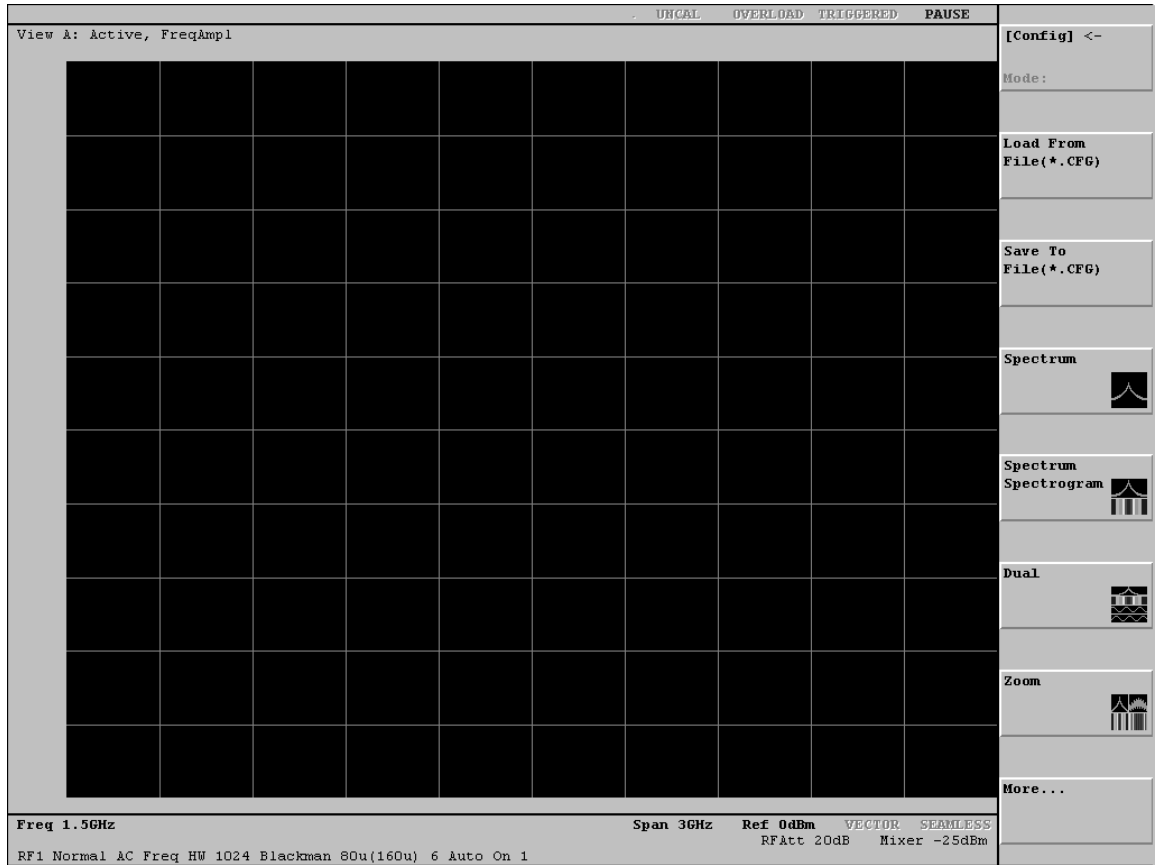


Figure 2-7: Initial screen

Adjusting the Display Tilt Angle

You can adjust the tilt angle of the display within the range of 0 to 30 degrees as appropriate to the lighting conditions in the room and the level of your eyes.

When you press the release bar at the bottom of the display, the bottom of the display slightly pops up toward you. While holding the display at its bottom, pull it up toward you until you find the optimal viewing angle.

If you want to return the display into the main cabinet, continue to press the bottom of the display until you hear a click.

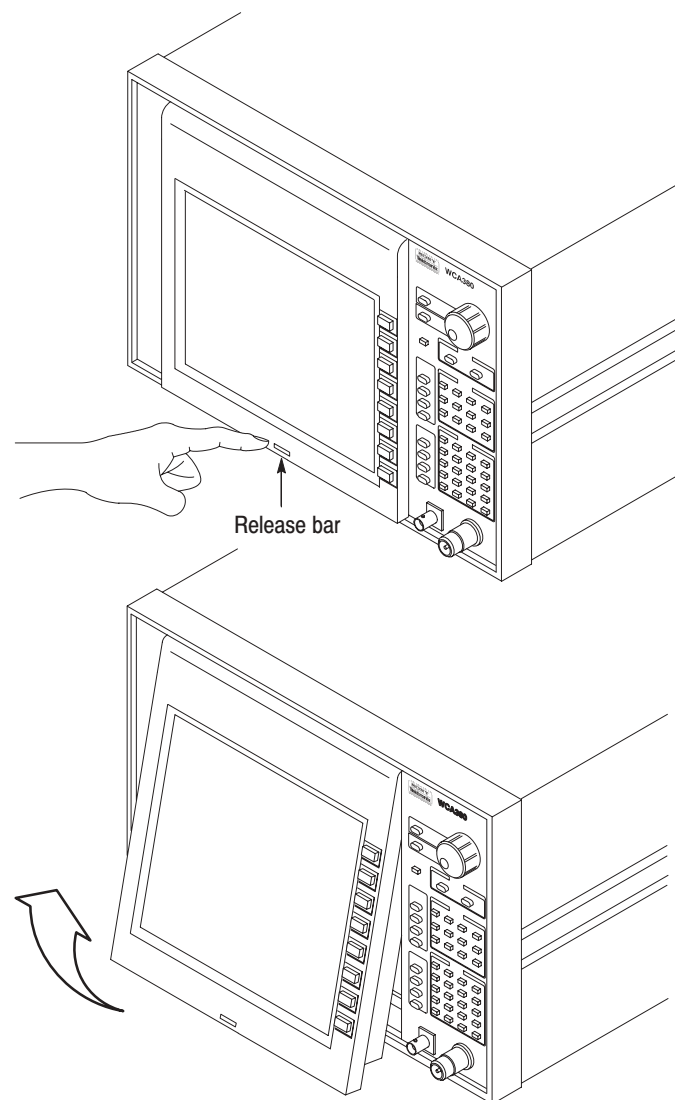


Figure 2-8: Angular adjustment of tilt display

Powering Off

- Place the power switch on the front panel in the **STANDBY** position.

When you place the power switch in the STANDBY position, the internal software detects the condition of the power switch, terminates measurement applications and Windows 98 and automatically powers off the analyzer. You do not have to terminate them manually. The STANDBY LED is lit after blinking for a while.

NOTE. *When you place the power switch on the front panel in the STANDBY position, the principal power supply is not turned off completely. When you want to turn off the principal power supply, you must place the principal power switch on the rear panel in the OFF position.*



CAUTION. *When you powering on or off the analyzer, be sure to use the power switch on the front panel. When the power cord remains unplugged from the AC outlet, or no voltage is being supplied to the AC outlet, be sure to keep the power switch in the STANDBY position.*

Resetting the Analyzer

When the analyzer does not seem to work properly, use the following procedure to power off the analyzer and power on again.

NOTE. *When the analyzer does not work properly, power is not shut off by returning the power switch on the front panel from ON to STANDBY.*

1. Make sure that the power switch on the front panel is in the **STANDBY** position.
2. Place the principal power switch on the rear panel in the **OFF** position.
3. 10 seconds later, place the principal power switch on the rear panel in the **ON** position.
4. Place the power switch on the front panel in the **ON** position.

When Scan Disk Appears

If the analyzer was not shut down properly, the Windows Scan Disk may be executed when you power it on. When the Scan Disk screen appears, perform the following procedure:

1. Perform either of the following:
 - Wait for about one minute with the Scan Disk screen displayed.
 - Attach a keyboard to the analyzer and press any key.

Scan Disk continues to run.

2. If no error is detected, applications on the analyzer are started.

If an error is detected, refer to an appropriate Windows manual. For how to access Windows on the analyzer, refer to the *User Manual*.

Repackaging Instructions

If you ship the analyzer, pack it in the original shipping carton and packing material. If the original packing material is not available, package the instrument as follows:

1. Obtain a corrugated cardboard shipping carton with inside dimensions at least 15 cm (6 inches) taller, wider, and deeper than the instrument. The shipping carton must be constructed of cardboard with 170 kg (375 pound) test strength.
2. If you are shipping the instrument to a Tektronix field office for repair, attach a tag to the instrument showing the instrument owner and address, the name of the person to contact about the instrument, the instrument type, and the serial number.
3. Wrap the instrument with polyethylene sheeting or equivalent material to protect the finish.
4. Cushion the instrument in the shipping carton by tightly packing dunnage or urethane foam on all sides between the carton and the analyzer. Allow 7.5 cm (3 in) on all sides, top, and bottom.
5. Seal the shipping carton with shipping tape or an industrial stapler.

NOTE. *Do not ship the instrument with a diskette inside the floppy disk drive. When the diskette is inside the drive, the disk release button sticks out. This makes the button more prone to damage than otherwise.*

Installed Options

Your instrument may be equipped with one or more instrument options. Except for the line-cord options described by Table 2-2 on page 2-2, all options and optional accessories are listed and described in Section 7, *Options*. For further information and prices of instrument options, see your Tektronix Products catalog or contact your Tektronix Field Office.

Operating Instructions

Before performing any service, read the following operating instructions. These instructions are at the level appropriate for servicing the analyzer. The user manual contains more complete operating instructions. This section describes basic procedures, such as applying power, displaying measurement results, and powering off the analyzer, using default settings as far as possible for simplicity. The following procedures are contained in this section:

- Connecting the instruments and powering up
- Setting the analyzer with basic configuration patterns
 - Measuring the spectrum
 - Measuring the digital modulated signal
- Making changes to the hardware settings
- View definitions and layout
- Using averaging and compared displays
- Using peak search and zoom functions
- Using delta markers
- Powering down

Additional instructions are integrated into the service procedures found in later sections of this manual. For instance, the procedures found in the section *Performance Verification* contain instructions for making the front-panel settings required to check each instrument characteristic included there. Also, the general instructions for operating the analyzer's internal diagnostic routines are found in Section 6, *Maintenance*. You may also find the *Product Description* in Section 1 useful for understanding how the analyzer functions.

Preparations

Prepare the following equipment for use in the examples:

- Digital modulated signal generator
Recommended signal generator: Rohde & Schwartz SMIQ
- One 50 Ω coaxial cable

Connecting the Signal Generator

1. Connect the signal generator output through the cable to the RF INPUT connector on the front panel (see Figure 2–9).

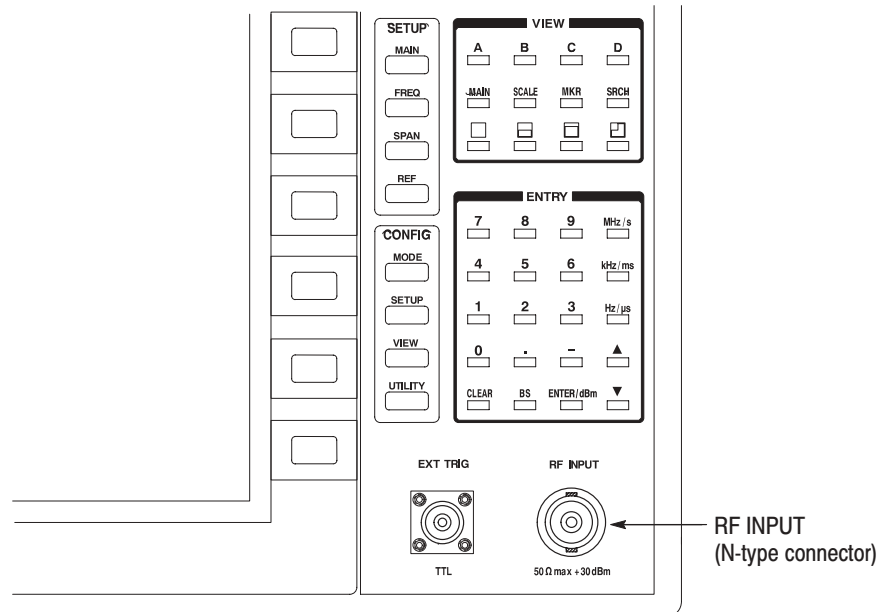


Figure 2–9: Cable connection

2. Set the signal generator as follows:

Center frequency	800 MHz
Modulation	PDC modulation system
Symbol rate	21 kHz
Filter	Root Raised Cosine
α /BT	0.5
Output level	-10 dBm
Modulation data	Quasi-random pattern

Applying Power

1. Power up the signal generator.
2. Press the principal power switch found on the rear panel of the analyzer, then press the power switch (**ON/STANDBY**) shown in Figure 2-10 to toggle the analyzer into operation.

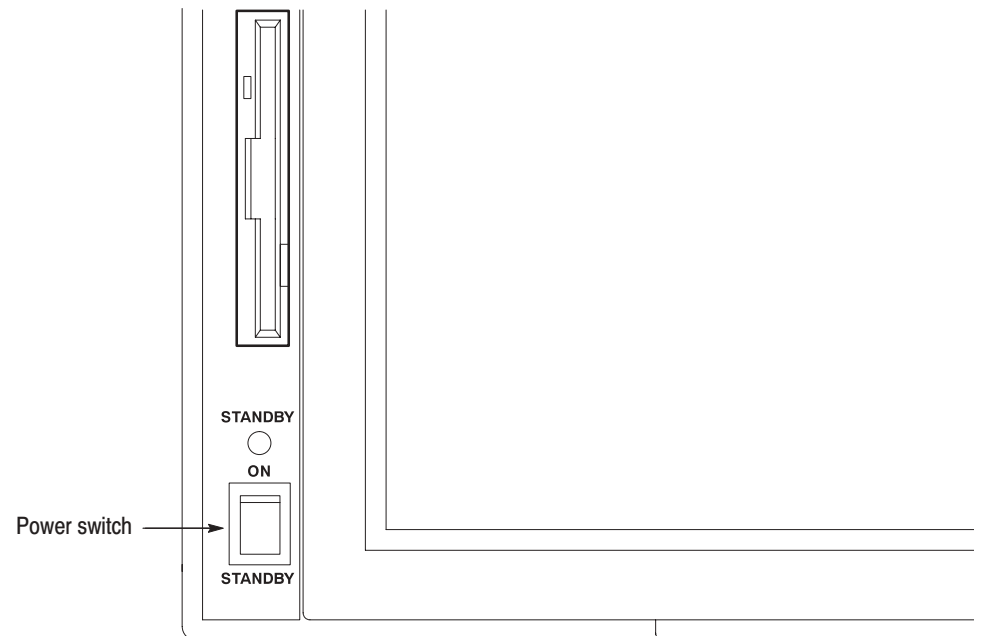


Figure 2-10: Power switch

The analyzer should boot up with the initial screen shown in Figure 2–11. Now, the preparations to operate the analyzer are complete.

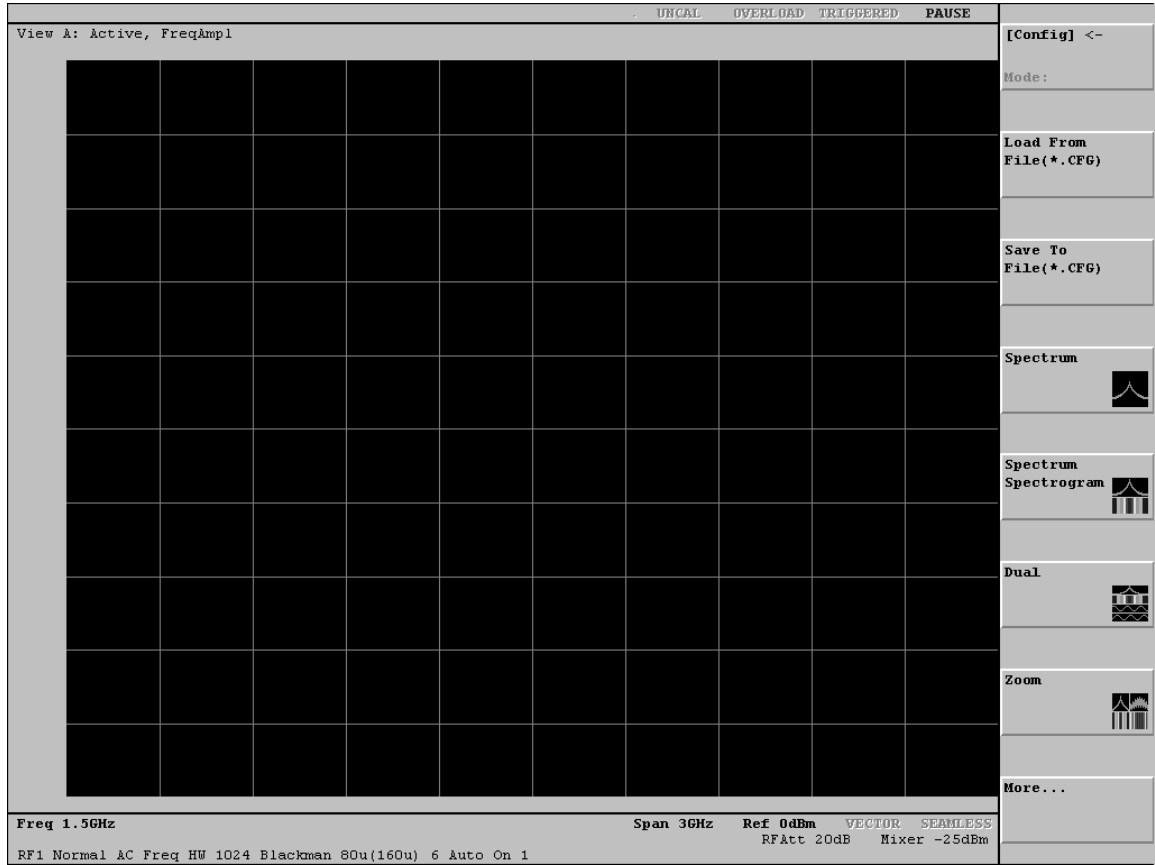


Figure 2-11: Initial screen

Setting the Analyzer with Basic Configuration Patterns

This section describes the easy way to measure a spectrum using the basic configuration patterns in the CONFIG:MODE menu.

Measuring the Spectrum

Follow these steps to quickly measure the spectrum of the input signal.

1. Press the **MODE** key in the CONFIG area (see Figure 2–12).

When you press the CONFIG:**MODE** key, the CONFIG:MODE menu is displayed at the right side of the screen.

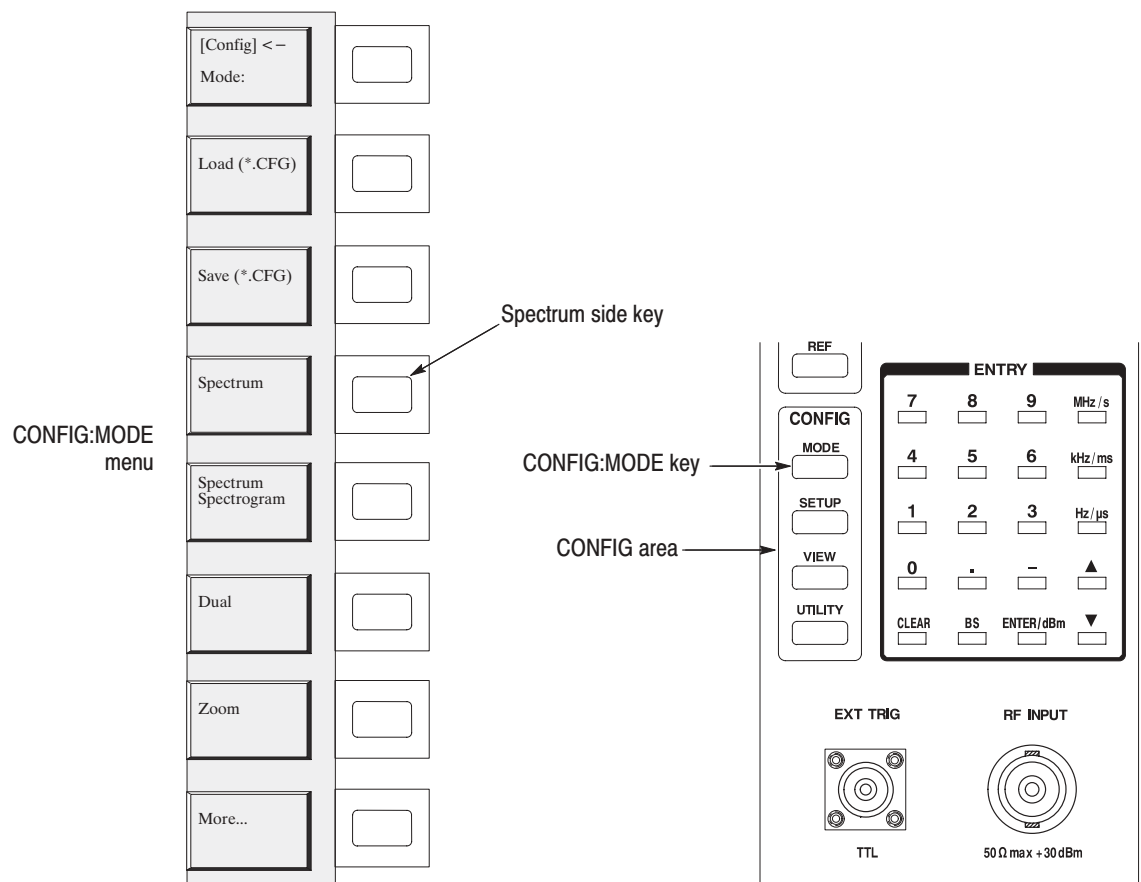


Figure 2–12: CONFIG:MODE key and the menu

2. Press the **Spectrum** side key.

This key selects measurement of the spectrum with a default span of 3 GHz and a center frequency of 1.5 GHz. The display in Figure 2–11 is unchanged because the initial screen defaults to the Spectrum.

Starting and Stopping Measurement (Roll Mode)

The Roll mode acquires data continuously and simultaneously displays current measurements of the displayed signal.

3. Press the **ROLL** key on the front panel.

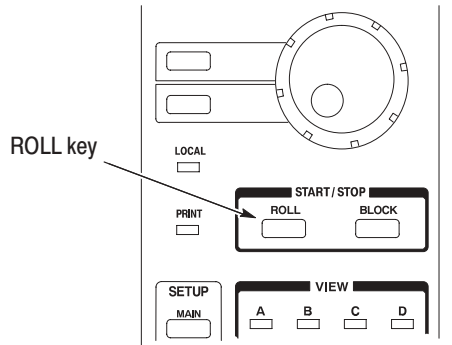


Figure 2-13: Control of the start and stop of measurement

Figure 2-14 shows an example of the spectrum display.

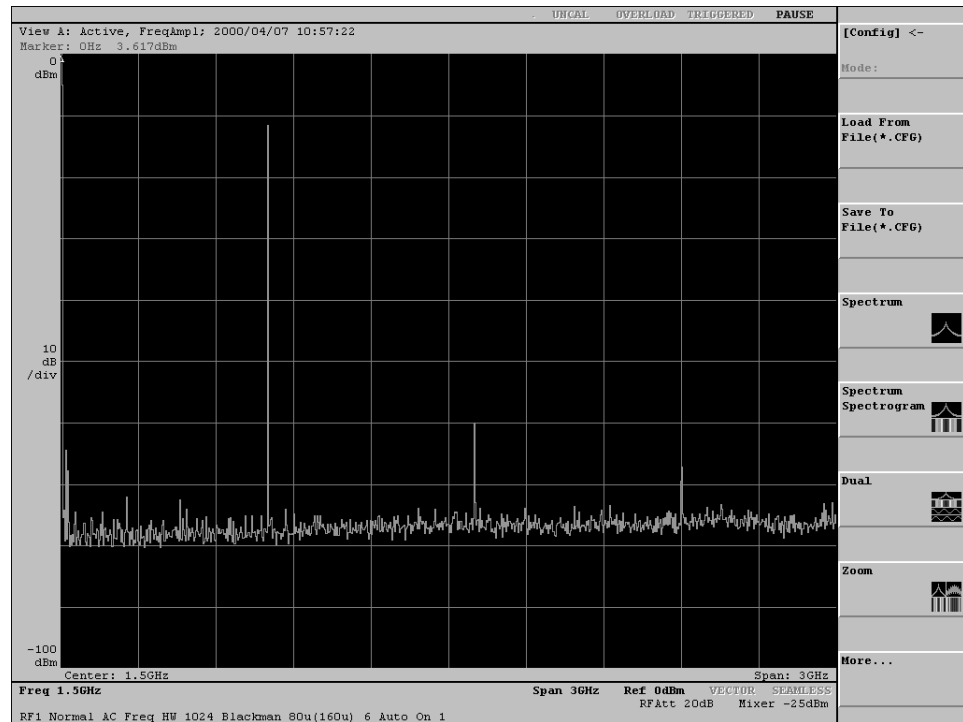


Figure 2-14: Spectrum measurement with a span of 3 GHz

4. Press the **ROLL** key to stop the measurement. See the PAUSE status in the status display area as shown in Figure 2–15.

If PAUSE is in blue: The measurement is currently stopped.

If PAUSE is in gray: The measurement is in progress.

Press the **ROLL** key to stop the measurement.

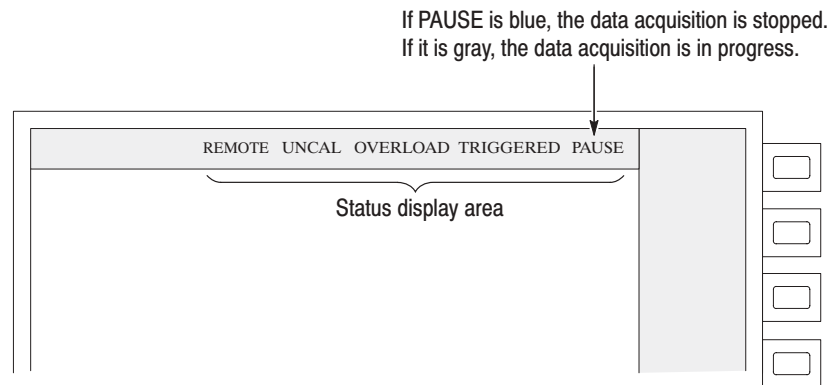


Figure 2–15: Status display area

Measuring a Digital Modulated Signal

Now, measure a digital modulated signal with the basic configuration pattern.

5. Press the **MODE** key in the CONFIG area again (see Figure 2–12 on page 2–17).
6. Press the **More...** side key and then **Digital Demod** side key in the menu.

The display view changes as shown in Figure 2–16. The analyzer is set to a span of 3 GHz and a center frequency of 1.5 GHz. It now displays the spectrum, spectrogram, vector (constellation), and EYE pattern in the four views.

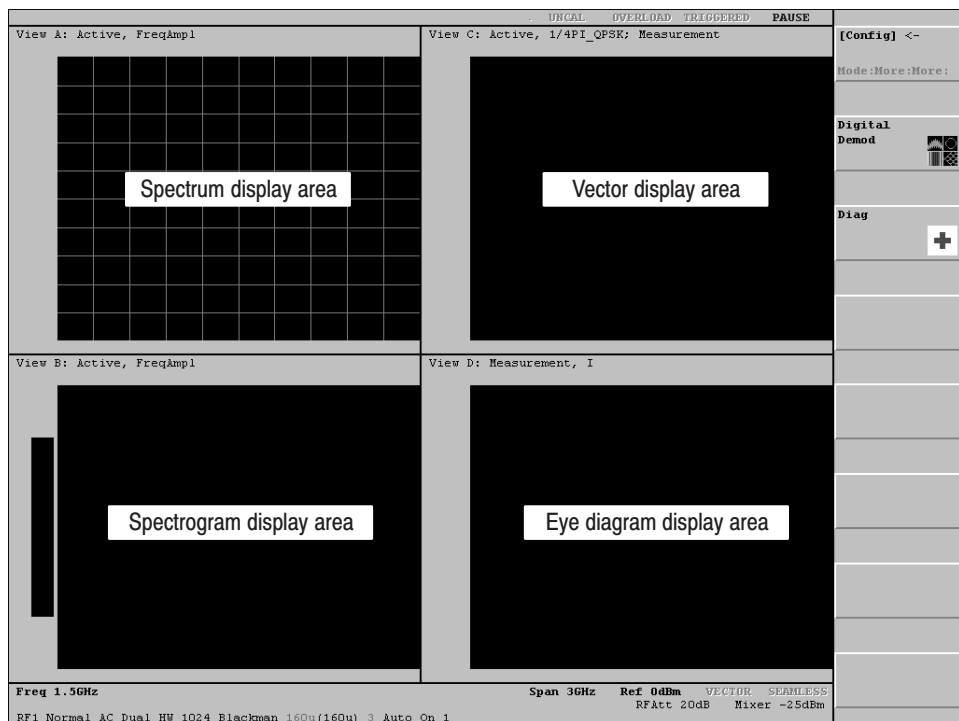


Figure 2–16: Four-view display for digital modulation analysis

Starting and Stopping Measurement (Block Mode)

Now, acquire a signal in the Block mode. This mode acquires the data in blocks before displaying the measurement result.

7. Press the **BLOCK** key.

Note that the Block mode is not yet active because of the current settings. The analyzer continues to use the Roll mode to acquire the signal. Figure 2-17 shows the current view.

The display in this example contains neither the vector nor the EYE pattern. It is because the span is so great (3 GHz) that the analyzer cannot capture the digital modulated signal. These views can be obtained by specifying a proper span and center frequency.

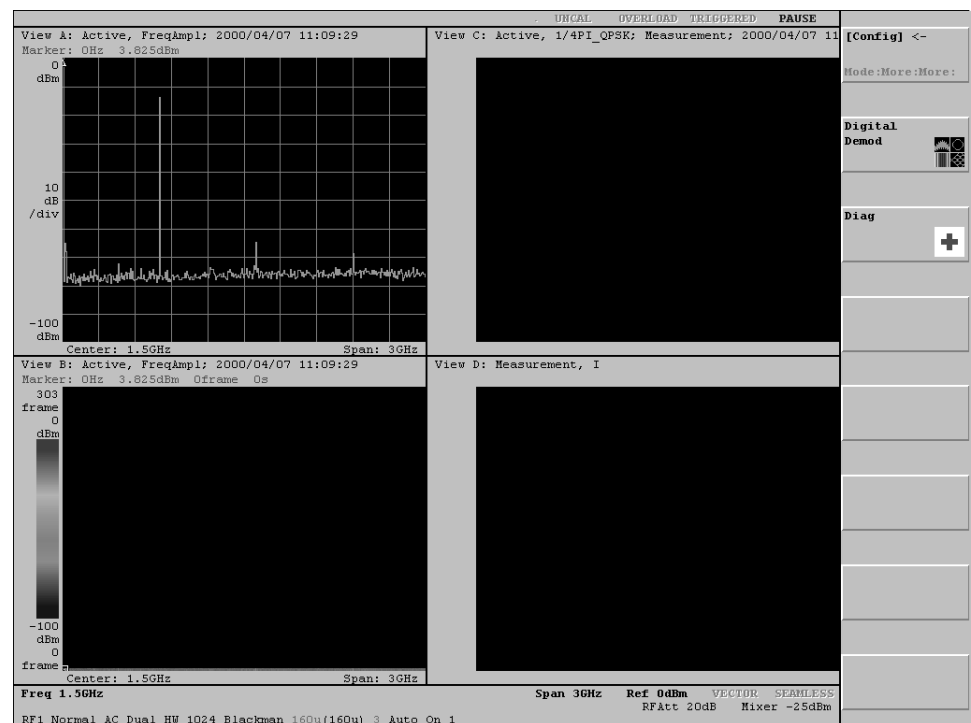


Figure 2-17: Measuring the digital modulated signal – Span 3 GHz

8. Stop the Roll mode acquisition (refer to step 4).

In the next example, you will acquire the signal in the Block mode by setting a proper center frequency and span.

Changing Hardware Settings

In this section, you learn how to make changes to the hardware settings through the SETUP menu.

For the previous views, the default center frequency and span settings were used for measurement. You can change the center frequency and span using the keys in the SETUP area and the SETUP menu.

Changing the Center Frequency

The center frequency is initially set to the default value 1.5 GHz. Change it to 800 MHz.

9. Press the **FREQ** key in the SETUP area (see Figure 2–18).

The Freq, Span, Ref... submenu is displayed in the menu display area. Note that numeric input in the Freq menu item is already available for adjustment.

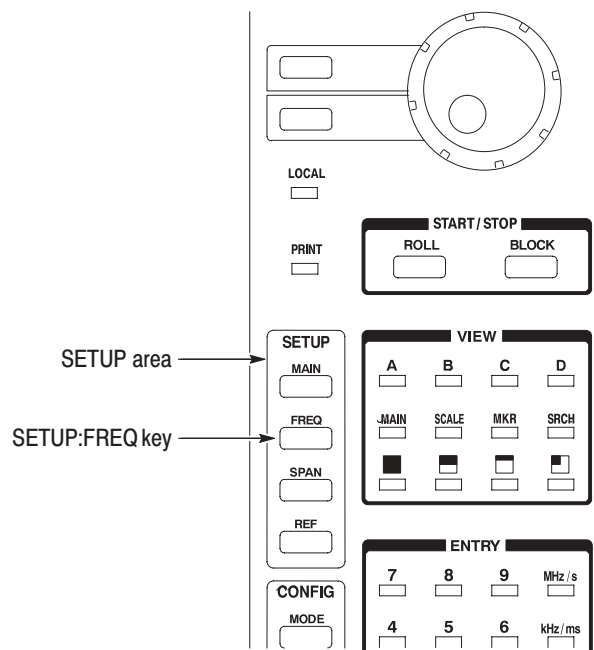


Figure 2-18: SETUP:FREQ key location

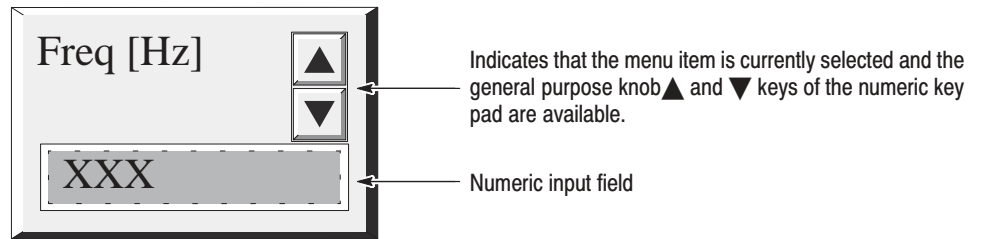


Figure 2-19: Freq side menu item available for numeric input

10. Input the new center frequency 800 MHz: In the ENTRY area, press the key **8 0 0 MHz/s** in order.

NOTE. When you input 800 MHz in this state, the display returns to 1.5 GHz. You must go on and set the span before the new center frequency (800 MHz) is available.

The **MHz/s**, **kHz/ms**, **Hz/μs**, and **ENTER/dBm** keys function in the same manner as the **ENTER** key. They establish the numeric value you typed in. When you press any of these keys, the hardware is immediately set up with the values you selected.

If you type in an erroneous digit, correct it using the **BS** (back space) or **CLEAR** key.

You can also change the numeric value using the general purpose knob or the ▲ and ▼ keys in the ENTRY area.

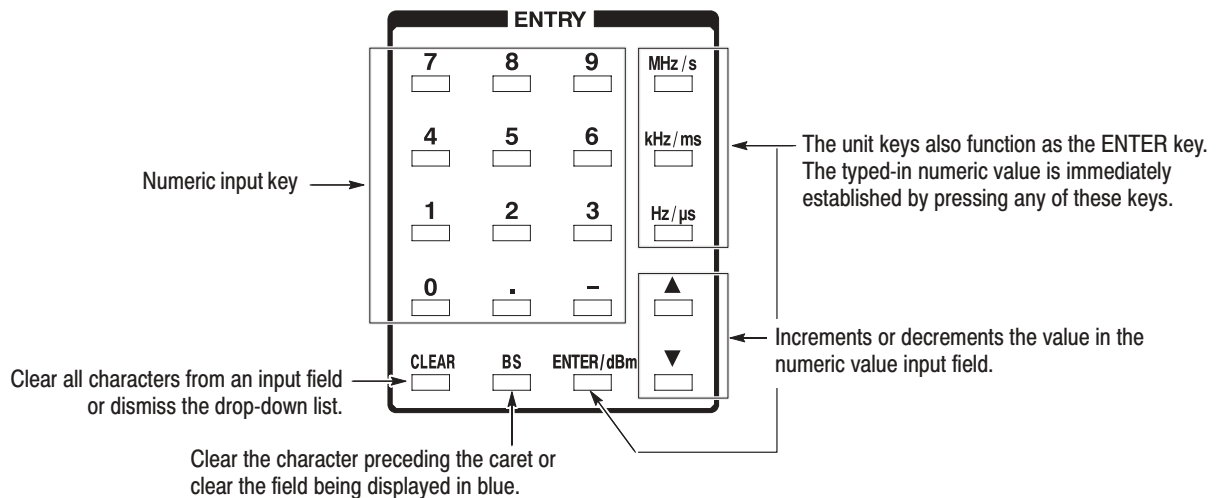


Figure 2-20: Numeric input keypad

Changing the Span

The currently displayed menu indicates that the span is set to the default value 3 GHz. Change it to 100 kHz.

11. Press the **Span** side key.

A drop-down list appears to select the desired item.

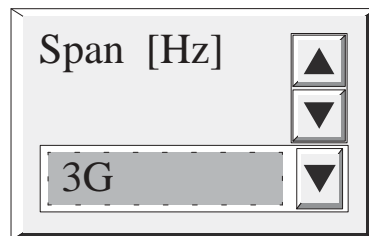


Figure 2-21: Span side menu item available for numeric input

12. Select **100k** using the general purpose knob.

13. Press the **Span** side key again.

The hardware is set up immediately with the new value.

NOTE. After the span has been changed, the relationship between the span and the frequency input in Step 10 falls within the allowable range. Now the 800 MHz center frequency, input previously, is displayed in the Freq menu.

Starting and Stopping the Measurement (Block Mode)

With the center frequency and span set to appropriate values, you can now use the Block mode to acquire data. This mode displays the result of measurement after the data has been acquired in blocks.

14. Press the **BLOCK** key on the front panel.

Unlike the Roll mode, the Block mode requires a longer time to display the data. This is because the data is displayed only after enough is acquired to fill the specified block size. After acquiring one block of data, the analyzer displays the data.

Make sure that SEAMLESS is displayed in blue in the setting status display area at the bottom of the display (see Figure 2–22). It indicates that the data is being acquired continuously, i.e., there is no time gap between two adjacent frames. The settings allowing the seamless acquisition depend on the frame period and span settings.

Also check that the PAUSE display is gray in the hardware status display area (see Figure 2–22).

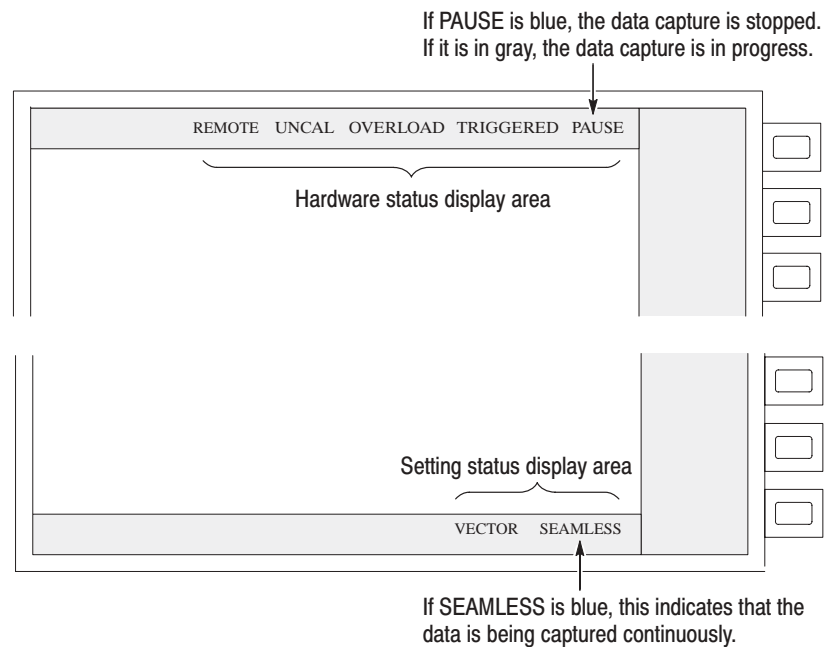


Figure 2-22: Setup display areas

Figure 2–23 shows the measurement result using the new center frequency and span. Note that the display scale has automatically changed in accordance with the center frequency and span settings.

You now have a proper vector display and Eye diagram. Try changing the span. This modifies the two views, especially the Polar view located at the top right corner on the display. It has a mechanism to demodulate the digital modulated signal. The Eye diagram view uses the demodulated signal in the Polar view. If the span is too great or small, the modulated signal cannot be analyzed.

Try changing the frequency in fine increments using the general purpose knob. Note how the display diagram changes.

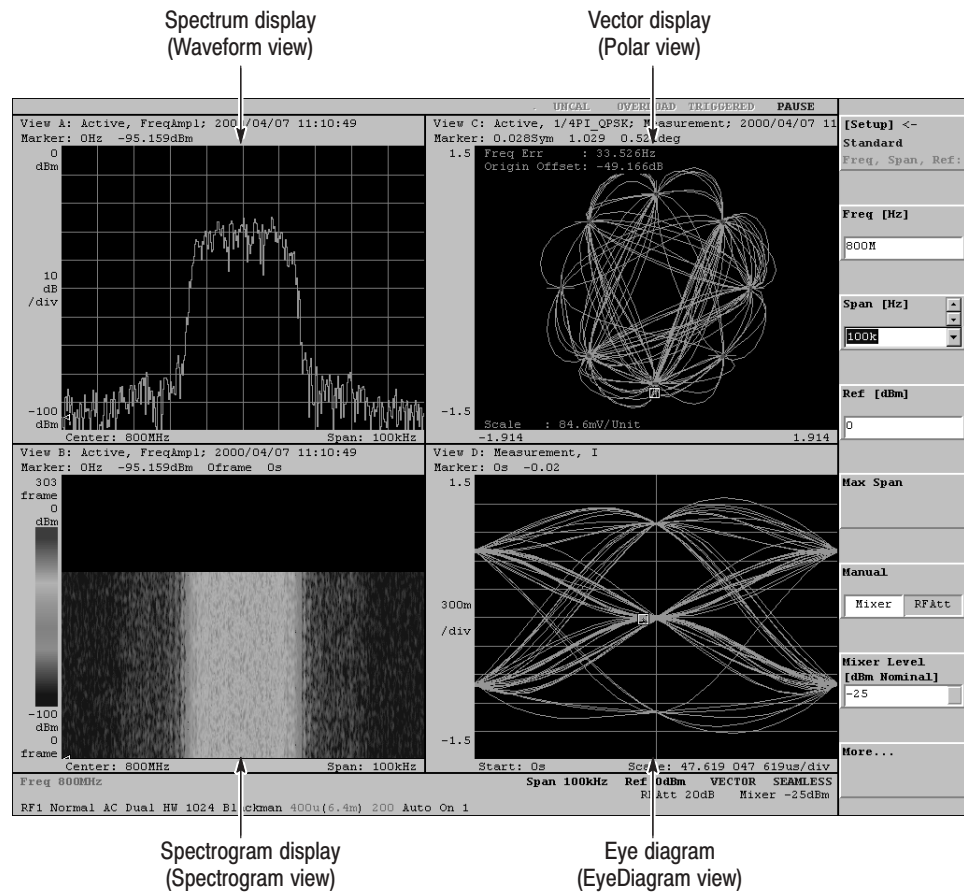


Figure 2–23: Views resulting from changes to the frequency and span settings

View Definitions and Layout

In this section, you learn how to define a view or a window used to display waveform and measurement results.

The view is a window used to display waveform and measurement results. This system allows you to define up to eight (A to H) views and display up to four views at the same time. You can specify how the waveform and results are displayed in each of the defined views.

In the subsequent sections, you modify the view located at the bottom right corner on the screen to the Waterfall display.

Checking the View Definitions

Four views of A to D are already defined with the basic configuration. First, check their definitions.

15. Press the **VIEW** key in the CONFIG area (see Figure 2–24 right).

The display area shows the menu used to set the format of the four views (see Figure 2–24 left).

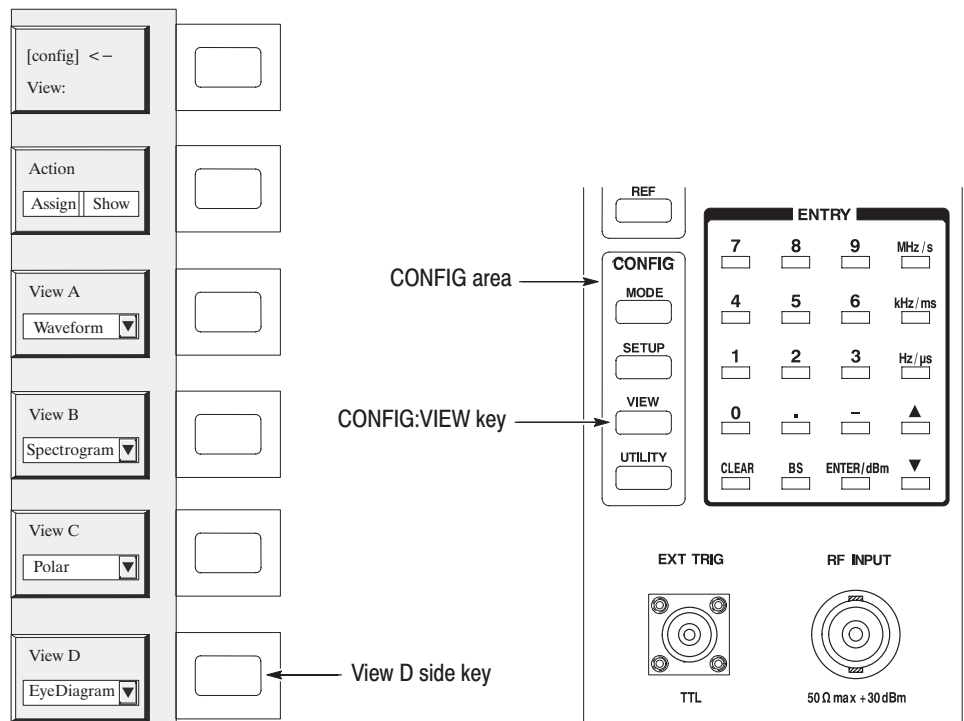


Figure 2–24: CONFIG:VIEW key and its submenu

Redefining a View

The view A to D are now defined as follows (see Figure 2–23 on page 2–26):

- View A (upper left of the screen): Waveform
- View B (lower left of the screen): Spectrogram
- View C (upper right of the screen): Polar
- View D (lower right of the screen): Eye diagram

Change the View D definition from Eye diagram to Waterfall.

16. Redefine View D:

- a. Press the **View D** side key.

A drop-down listing appears to select the desired item (see Figure 2–25).

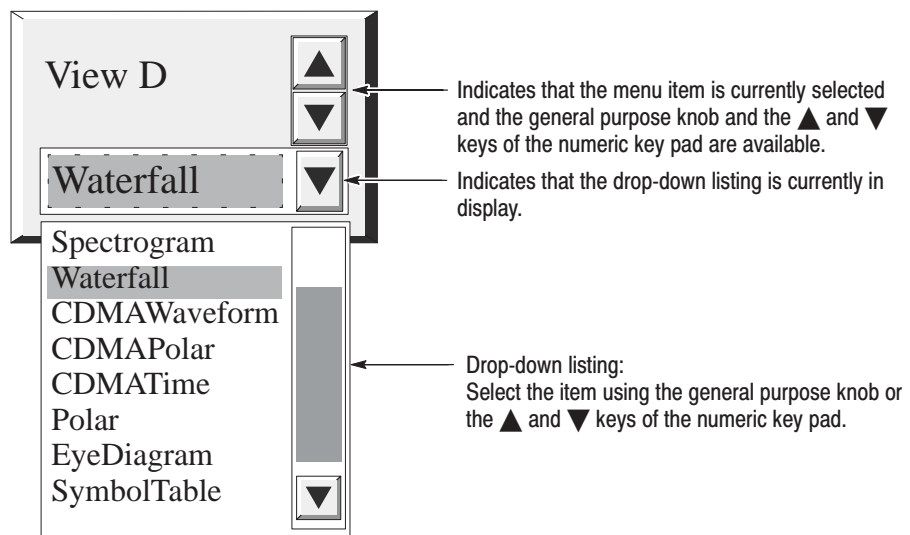
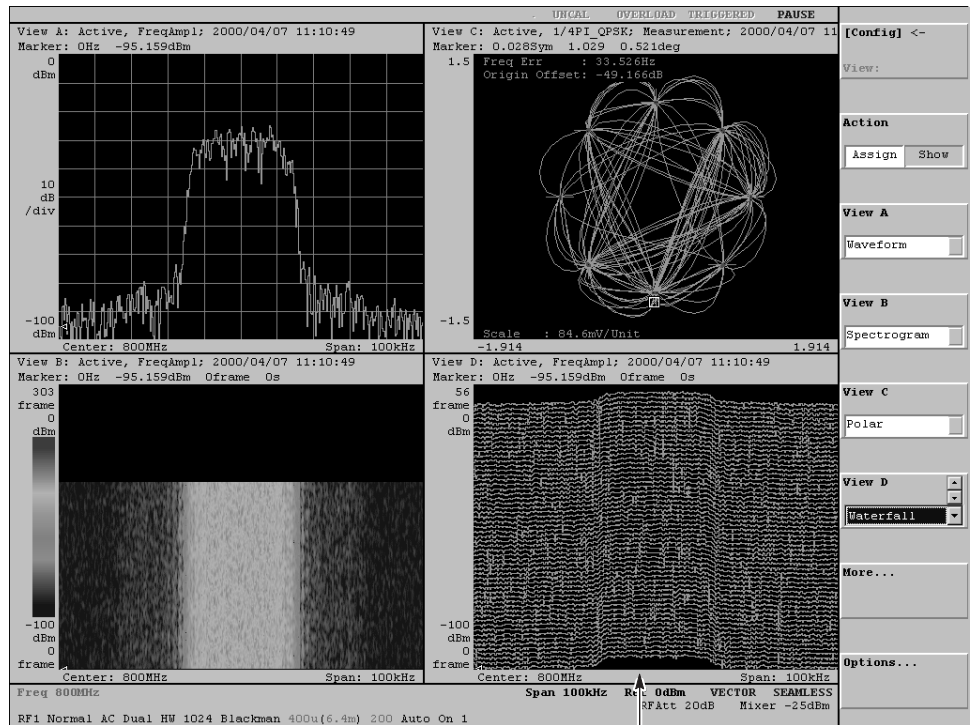


Figure 2–25: Selecting the Waterfall view

- b. Select **Waterfall** from the drop-down listing by turning the general purpose knob.
- c. Press the **View D** side key again to enable the view settings.

Figure 2–26 shows an example of the views with the new settings.



Waterfall view

Figure 2-26: Making changes to View D

View Layout The views are placed in predefined positions on the display screen. At present, they are placed in the two-by-two layout as shown in Figure 2–27. If a view is not defined, the area is empty.

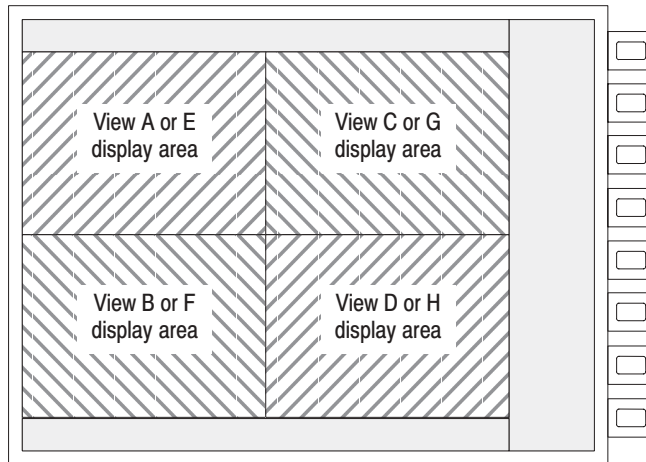



Figure 2-27: Four-view display layout

17. Modify the View B display layout. See Figure 2–28

- a. Press the  key in the VIEW area.
- b. Press the **B** key in the VIEW area.

View B is displayed fully on the screen. See Figure 2–29.

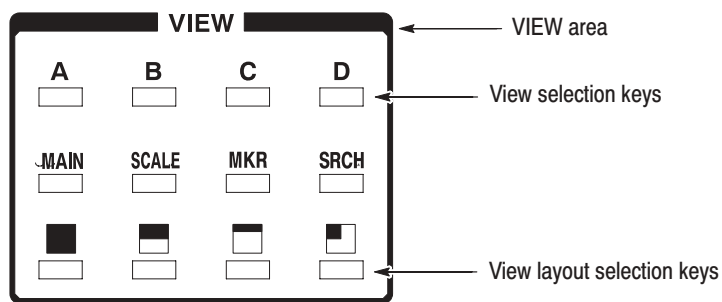


Figure 2-28: VIEW keys (view control keys)

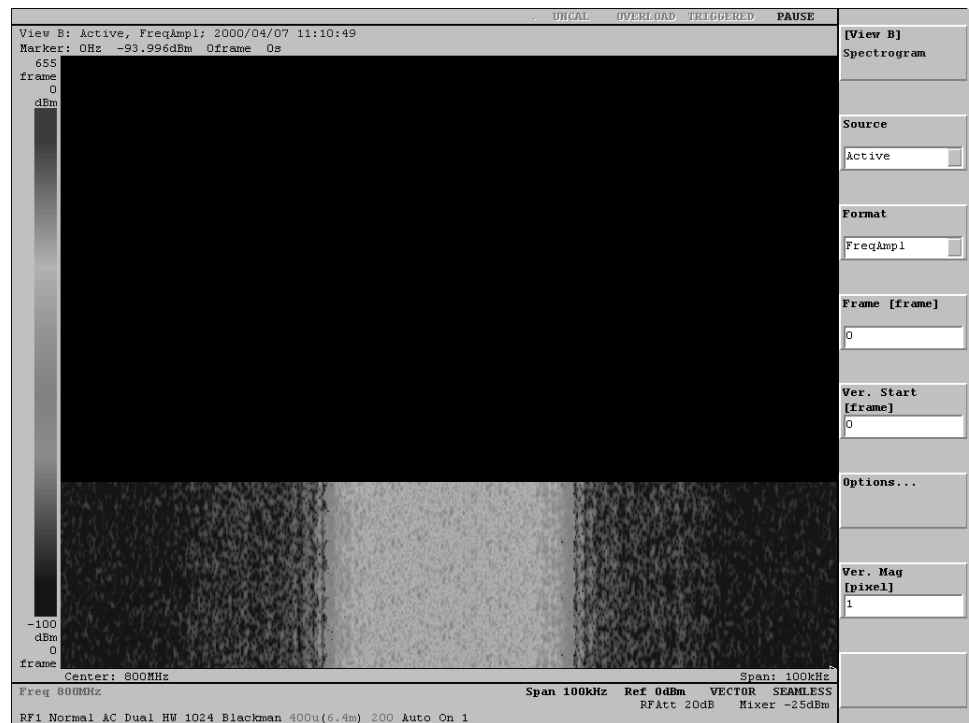





Figure 2-29: View B display (1-view display)

- c. Try pressing the **A** to **D** keys in the VIEW area.
- d. Try pressing the , , and  keys and the **A** to **D** keys in various combinations to see the possible view configurations.

Averaging and Compared Display

The Waveform view has the averaging function that reduces noise on a waveform. In this section, you learn how to compare averaged waveform with the original.

Setting Up the Averaging

The Waveform view is predefined for View A. Modify the averaging parameters.

18. Modify the averaging parameters:

- a.** Press the **VIEW:A** key. (“VIEW:A” means the **A** key in the VIEW area on the front panel. The keys may mentioned like this hereafter.)
- b.** Press the **VIEW:MAIN** key.
- c.** Press the **Average...** side key.
- d.** Press the **Average** side key to select **On**.
- e.** Press the **Average Type** side key to select **RMS**.
- f.** Press the **Num Averages** side key to set the number of sweeps for averaging. For example, enter **64** using the numeric keypad or the general purpose knob.

Acquiring and Displaying the Signals

Perform the averaging.

19. Press the **ROLL** key on the front panel.

The averaging does not work if you press the **BLOCK** key. Pressing the **BLOCK** key displays the original spectrum without averaging.

The averaged waveform is displayed on the screen. With the averaging parameter settings above, the process stops after 64 sweeps. If you want to restart the averaging, press the **Reset** side key.

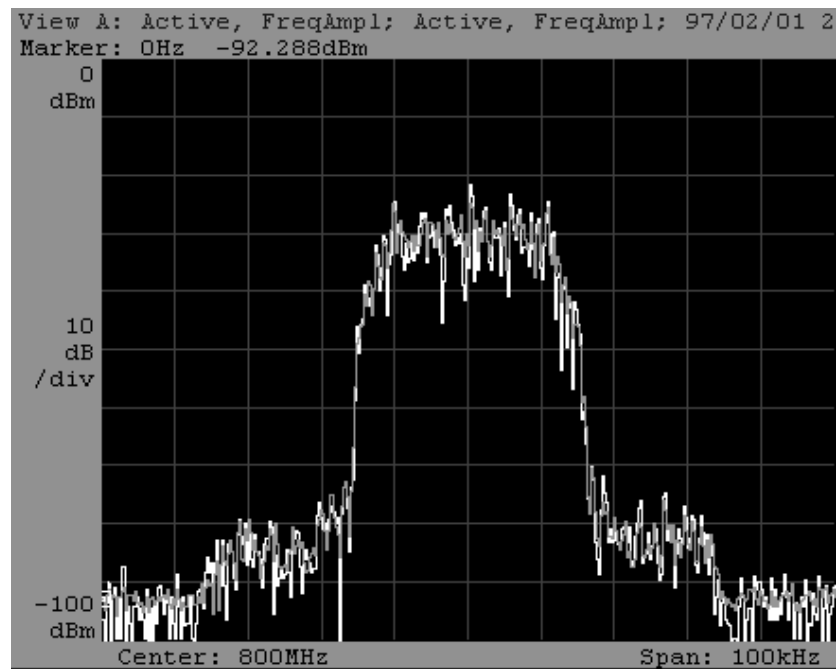


Figure 2-30: Averaging and compared waveform display

Setting Up the Compared Display

You can display two waveforms for comparison.

20. Make settings to display the averaged and the non-averaged waveforms at the same time:
 - a. Return to the previous menu level by pressing the [**View A**]<- side key (top side key).
 - b. Press the side key **Options...** → **Trace2...** → **Source**.
 - c. Select **Active** using the general purpose knob.

View A displays a green and a yellow trace (see Figure 2-30). The white trace represents the non-averaged waveform and the grayish trace the averaged waveform.

Peak Search and Zoom

In this section, you learn to use the peak search and zoom functions.

The zoom expands a specific section of the obtained spectrum and displays it. The analyzer remakes the frequency domain data, with a specific frequency and span, based on the time domain data. Therefore, it is capable of enlarging the view by a factor of up to 1000 without sacrificing the precision of observation.

Setting the Zoom Mode

To expand the display, you must first acquire the waveform in the Zoom mode.

21. Place the analyzer in the Zoom mode:

- a.** Press the **CONFIG:MODE** key.
- b.** Press the **Zoom** side key.

The analyzer is now in the Zoom mode. The center frequency and span settings are still unchanged. Check them with the menu.

22. Press the **SETUP:FREQ** key.

With the Freq and Span menu items, make sure that the center frequency and span settings are 800 MHz and 100 kHz, respectively. If you changed these settings previously, they will not be reset when you change acquisition or display modes. To set them, follow the steps listed on pages 2–22 and 2–24.

Acquiring the Signal

The zoom function requires the Block mode.

23. Press the **BLOCK** key on the front panel to acquire the signal.

Figure 2–31 shows an example of the signal acquired in the Zoom mode.

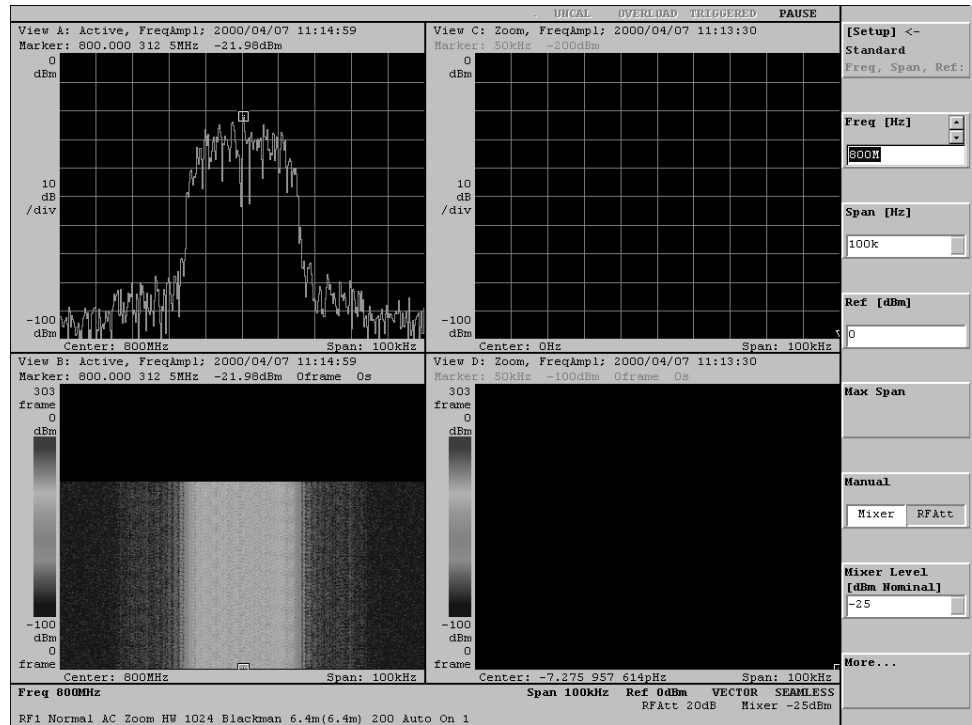


Figure 2-31: Signal acquisition in the Zoom mode

Searching for the Peak

Define a new center frequency and expansion factor for the acquired waveform. Use the search function to search for the peak signal with the maximum intensity and set the peak frequency to the center frequency.

24. Using the search function, search for the peak spectrum:

- a. Press the **VIEW:A** key.
- b. Press the **VIEW:SRCH** key.

A marker (□) is positioned at the maximum peak spectrum. This frequency becomes the center frequency for zooming in the next step.

Executing Zoom

Execute zoom around the center frequency found with the search function.

25. Run zooming:

- a. Press the **SETUP:MAIN** key.
- b. Press the **Zoom...** side key.

Note that the Frequency menu item contains the new frequency resulting from the search.

- c. Press the **Mag** side key to set the expansion factor to **100** using the general purpose knob.
- d. Press the **Execute** side key.

The expanded view is displayed in Views C and D as shown in Figure 2–32.

In View D, the number of displayed frames is

$[(\text{block size})/(\text{expansion factor}) - 1]$ (In this case, $200/100-1=1$).

You can repeat steps c and d for different expansion factors.

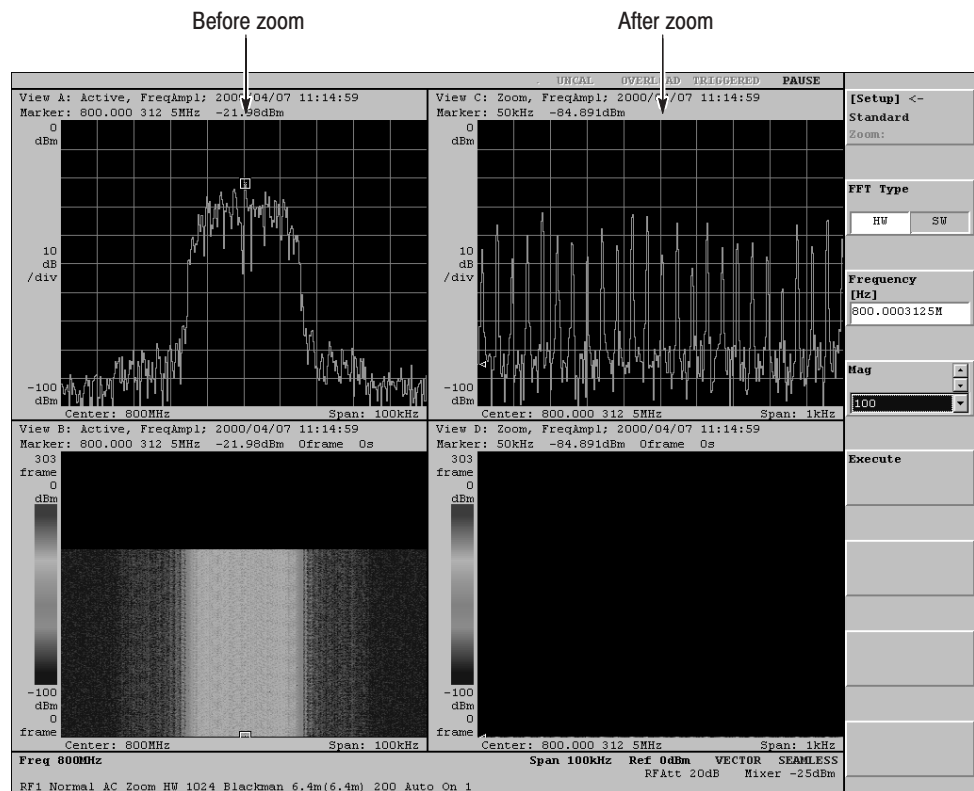



Figure 2–32: Example of zooming

Delta Markers

In this section, you learn how to operate the delta markers. Delta markers let you accurately measure the difference between two frequencies.

A comb spectrum waveform can be observed in View C in Figure 2–33. Measure the difference between the frequencies of adjacent spectrum peaks.

26. For better visibility, change View C to a single view display:

- a. Press the VIEW:C key.
- b. Press the VIEW:  key.

View C changes to single view display. See Figure 2–33.

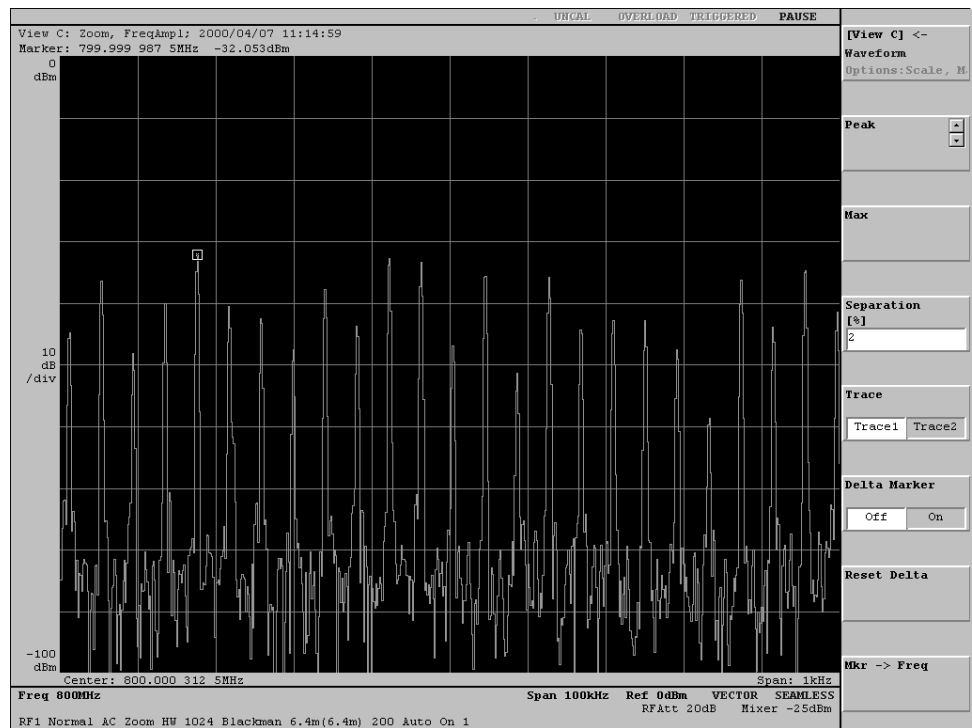


Figure 2–33: Moving the markers by peak search

Searching for the Peak

For example, we measure the interval between the peak spectrum with the maximum power and the adjacent peak to its the right.

27. Position the marker at the maximum peak spectrum:

- Press the VIEW:SRCH key.

The marker (□) is positioned at the maximum peak spectrum as shown in Figure 2–33.

Operating the Delta Markers

Position the delta markers for a measurement.

28. Operate the delta markers:

- a. Press the VIEW:MKR key.
- b. Press the **Delta Marker** side key and select **On**.

The delta markers (□ and ◇) turn on.

29. Measure the frequency interval between two peaks:

- By rotating the general purpose knob, move the □ marker to the adjacent right peak.

At the top left corner, the view shows the differences in frequency and power resulting from the delta marker measurement. See Figure 2–34.

Result of delta marker measurement

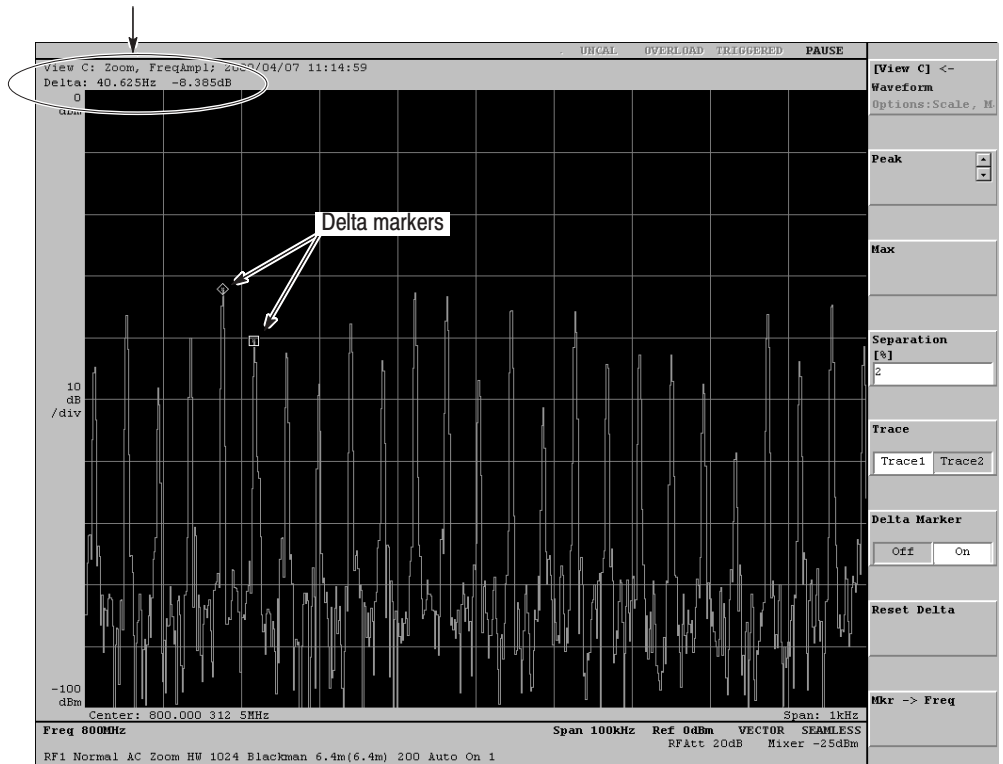


Figure 2-34: Measurement example using the delta markers

Theory of Operation

Theory of Operation

This section describes the electrical operation of the WCA330 and WCA380 using the major circuit blocks or modules as shown in Figure 9–1.

Module Overview

3 GHz / 8 GHz Down Converter

The down converter converts input RF signals with frequencies up to 3 GHz (WCA330)/ 8 GHz (WCA380) to the Baseband (10 MHz or lower), Normal and Wide intermediate frequency (IF) signals. The Baseband and Normal IF signals are sent to the A12 IF Gain board, while the Wide IF signals to the A22 Wide ADC board.

The down converter consists of two main modules: U10 ERF4000 and U11 ERF4001. U11 ERF4001 receives input signals and processes them with the programmable attenuators and YIG tuning filter (YTF; 3.5–8.0 GHz). The Baseband signals are sent directly from U11 to the A12 IF Gain board. RF signals are sent to U10 ERF4000. U10 contains a three-stage (1st/2nd/3rd) IF converter and a phase-locked synthesizer. The input RF signals are mixed with respective LO signals through the mixer within the converter, then converted into IF frequency signals for each level. Each of the LO signals is generated by the synthesizer based on the reference frequency. For the Wide IF signals, U10 has a wideband synthesizer, mixer, and a wide IF amplifier. Also, it contains a calibration signal generator, and a 10 MHz reference frequency selecting and distributing circuit.

The calibration signal generator produces highly stable signals of 25 MHz for calibrating conversion gains. The 10 MHz reference frequency selecting and distributing circuit selects an internal or external 10 MHz reference frequency, and outputs the signals to the synthesizer, the clock generating circuit on the A40 Memory board, and the 10 MHz output connector located on the rear panel.

IF Gain and A/D Boards (A12 and A13)

The Baseband and Normal IF signals from the down converter are input and amplified with the A12 IF Gain board, then filtered and A/D converted with the A13 IF A/D board.

The A12 IF Gain board amplifies the Baseband and Normal IF signals by selecting the AC/DC/GND input coupling for the Baseband signals. The A13 IF A/D board has a 10 MHz low-pass filter for the Baseband signals and a 18 MHz band-pass filter for the Normal IF signals. The filtered signals are A/D converted with the 14-bit 25.6 MS/s A/D converter.

Signals are processed with DC offset cancellation, as well as DC level shift fitted within the input range of A/D converter by the input buffer, then input to the A/D converter. The output level of signals from the input buffer is monitored by the excessive input signal detection circuit. If the specified level is exceeded, “OVERLOAD” is displayed on screen.

DDC Board (A20)

The A20 Digital Down Converter (DDC) board consists of an IQ splitter, a digital mixer, a digital filter, and other components. It performs digital signal processing including IQ separation and frequency conversion, which are required to perform high-speed FFT operation, then outputs the signals to the FFT board.

The 14-bit digital data from the A13 IF A/D board is processed with frequency conversion and IQ separation by the digital orthogonal mixer, then unwanted bands are cut out and a sample rate is changed by the subsequent digital filter. With the secondary digital mixer, frequency conversion depending on the settings of center frequency is performed, and limiting band according to the span settings and sample rate change are performed by the subsequent multiple-step digital filter.

Wide ADC Board (A22)

The A22 Wideband A/D Converter (ADC) board converts the Wide IF signals to digital data for the FFT processing. It contains an IQ splitter, a twin A/D converter, a wideband digital filter, and FIFO.

The IQ splitter splits the wide IF signal from the down converter to the I and Q components. Also, I and Q signals can be directly input from the rear panel connectors. The twin A/D converter (12-bit $40.96 \text{ MS/s} \times 2$) converts the analog I and Q signals separated by the IQ splitter to the digital quantity, respectively. The wideband digital filter thins out the sampling clock to change the span. The FIFO stores the data from the wideband digital filter and outputs them to the A20 DDC board, synchronizing with the data stream from the analog front end.

FFT Board (A30)

The A30 FFT board has an input FIFO, an FFT processor, an output FIFO, a trigger processor, and a clock generating and distributing circuit. It sends out I/Q data converted into frequency domain data, time domain data without conversion, and trigger signals, to the A40 Memory board.

The input FIFO consists of multiple dual-port RAMs and a control circuit. The input FIFO groups input data in units of 1024 or 256 points from the DDC board, and sends them to the FFT processor at a fixed clock rate. The data rate may vary significantly depending on the setting for the span.

The FFT processor converts time domain data grouped in units of 1024 or 256 points into frequency domain data at a high speed. The frequency domain data output from the FFT processor is reduced in its data rate by the subsequent output FIFO, and sent out to the Memory board.

The FIFO processing system starting from the input FIFO and ended with the output FIFO is divided into two systems, in order to improve an operating rate, thus real-time analysis up to 5 MHz span is made available. The time domain data sent from the DDC board branches to the two systems; data branched to one system are converted to frequency domain as described above, while the data for the other system are timed with the frequency domain data by being passed through the two-step configured FIFO, and sent to the subsequent Memory board while they are not yet converted but remain as the time domain data.

The trigger processor consists of a multiplier, an adder, and a magnitude comparator. The momentary power supply calculated in real time based on the I/Q data is compared with the trigger conditions specified to generate trigger signals, then output to the A40 Memory board. The clock generating and distributing circuit provides synchronized system clock used by the FFT and Memory boards.

Memory Board (A40)

The A40 Memory board stores the I/Q data collected and controls the signal processing hardware. It has an acquisition memory made up of data banks 0, 1, and 2, and a trigger memory. This board also includes an address counter, a local controller and its peripheral circuits, a clock generating circuit, and an external trigger input circuit.

The acquisition memory consisting of a set of three data banks 0, 1, and 2, has capacities of 4 MB, 4 MB, and 8 MB, respectively, and stores I/Q data for frequency domain and time domain in real time. The operation of the memories and actual data to be stored on the memories will vary depending on the mode of each memory; Frequency, Dual, and Zoom. The Zoom mode is implemented by returning the time domain data written on Data Bank 2 to the FFT processor on the DDC board once, then re-writing the frequency domain data performed with the FFT operation on Data Bank 0.

The trigger memory stores the trigger conditions created by editing the mask patterns. The trigger conditions are compared with the acquisition data by the magnitude comparator equipped on the FFT board. The address counter generates an address for one bin or one point, and maps addresses on the memories.

The local controller sets up and controls all the signal processing hardware ranging from the down converter to the Memory board, and sends out the upper bit addresses to the acquisition memory to control frames for each memory. The clock generation circuit has a digital control VCXO, generating sampling clocks for the A/D converter locked with the 10 MHz reference frequency supplied from the down converter. The external triggering input circuit detects a rising edge of external trigger signals and sends them to the local controller.

CPU Board, Data Storage, and External Interfaces

The CPU board has an Intel Celeron processor (433 MHz) and 128 Mbyte DRAM. Installed with Windows 98, it controls the entire system including the user interface, data acquisition, process, and display, and external interfaces.

Data is stored in the following mass storage devices:

- 40 Gbyte hard disk
- 3.5-inch floppy disk
- 8 Mbyte flash disk

The CPU board has the following interface connectors:

- Keyboard
- Mouse
- LAN Ethernet (10/100BASE-T)

It also controls the following external interfaces:

- GPIB
- Centronics parallel

Mother Board (A50)

The A50 Mother board provides the local bus connectors to be inserted with the A20, A22, A30, and A40 boards, and the ISA/PCI bus connectors to be inserted with the CPU and GPIB boards. It also includes a bus bridge circuit required to provide accesses to the memory system for A40 via the PCI bus, and some stabilized power supply circuits. The Mother board controls the interfaces between the boards and supplies the power. The power supply circuit on the Mother board generates +20 V and +8 V output power using +24 V input power, to be supplied to the A12 IF Gain board.

Power Supply (A71, A72, A73)

The power supply consists of an AC/DC converter unit, the A70 DC Power-1, A71 DC Power-2, and A72 DC Power-3 boards. It controls the power source and supplies power to all of the circuitry in the analyzer. The AC/DC converter unit generates the power of DC 48 V from the AC line input, and supplies the power to the DC Power-1 and DC Power-2 boards.

The DC Power-1 board generates the power of +24 V/+12 V, analog -12 V/+5 V, and analog -5 V/+8 V from the +48 V input power via the DC/DC converter equipped on the board. Then it supplies the power to the boards through the Mother board. The DC Power-1 board is also equipped with the power switch and the power supply remote control circuit, turning off the power supply upon detection of the signal from the CPU board, thus preventing accidents caused by any unintentional shut down of the power.

DC Power-2 board generates +12 V and +5 V digital power supplies from the +48 V power via the DC/DC converter on the board, and supplies such power to the hard disk unit, LCD display unit, fans, as well as to the boards through the Mother board.

The DC Power-3 board connects to the On/Standby switch. It generates +48 V for the DC Power-1 board and +5 V backup for the CPU board from ± 15 V and +5 V of U41 Standby Power Supply.

The DC Power-3 board has also a highly stable oven-controlled crystal oscillator (OCXO) that supplies the internal 10 MHz reference frequency to the down converter. All the synthesizers and oscillators contained in the analyzer output the frequency locked with the 10 MHz reference frequency selected and distributed by the down converter.

**LCD Display Unit and
LVDS Buffer Board (A62)**

The LCD display unit is a 12.1-inch TFT/LCD panel that displays the screen information created by the CPU board. The output from the LCD Controller board inserted into the PCI slot on the Mother board is buffered on the A62 LVDS Buffer board once, and added to the LCD display unit.

Front Panel Board (A60)

The A60 Front Panel board sends the key data, coded by the key encoder, to the CPU board.

Performance Verification

Performance Verification

Two types of Performance Verification procedures can be performed on this product: *Self Tests* and *Performance Tests*. You may not need to perform all of these procedures, depending on what you want to accomplish.

- To rapidly confirm that the analyzer functions and was adjusted properly, just do the *Self Tests*, which begin on page 4–3.

Advantages: These procedures require minimal additional time to perform, require no additional equipment, and more completely test the internal hardware of the analyzer. They can be used to quickly determine if the analyzer is suitable for putting into service, such as when it is first received.

- If more extensive confirmation of performance is desired, do the *Performance Tests*, beginning on page 4–11, after doing the *Self Tests* just referenced.

Advantages: These procedures add direct checking of warranted specifications. They require more time to perform and require suitable test equipment. (Refer to *Equipment Required* on page 4–13).

Conventions

Throughout these procedures the following conventions apply:

- Each test procedure uses the following general format:
 - Title of Test
 - Equipment Required
 - Prerequisites
 - Procedure
- Each procedure consists of as many steps, substeps, and subparts as required to do the test. Steps, substeps, and subparts are sequenced as follows:
 1. First Step
 - a. First Substep
 - First Subpart
 - Second Subpart
 - b. Second Substep
 2. Second Step
- Instructions for menu selection follow this format:
FRONT PANEL BUTTON → **Side Menu Button** → **Submenu Button**.
For example, “Press **SETUP:MAIN** → **Band** → **RF**”.
“**SETUP:MAIN**” indicates the **MAIN** button in the **SETUP** menu area on the front panel.
- In steps and substeps, the lead-in statement in italics instructs you what to do, while the instructions that follow tell you how to do it. In the example step below, “*Set the WCA380 analyzer controls*” by doing “Press **SETUP:MAIN** → **Band** → **RF**”.

*Set the WCA380 analyzer controls: Press **SETUP:MAIN** → **Band** → **RF**”*

STOP. The symbol at the left is accompanied by information you must read to do the procedure properly.

Self Tests

The self tests use internal routines to confirm basic functionality and proper adjustment.

The self tests include these internal routines:

- *Initial test*

The instrument automatically performs internal diagnostics at power-on.

- *Self calibration*

This procedure checks the instrument internal calibration constants and changes them if needed.

- *Diagnostics*

The diagnostic procedure uses internal routines to verify that the instrument functions, and passes the internal circuit tests.

The following provides the details.

Initial Test

The power-up self tests check the analyzer ROMs, RAMs, and A20 DDC board as listed below. No test equipment is required.

Table 4-1: Initial test process

Test item	Internal process
ROM	Check the ROMs by reading data and examining the check sum.
RAM	Check the RAMs by writing and reading data.
A20	Check whether the A20 DDC board is installed or not.

To display the results, do the following procedures:

1. Press any key in the CONFIG area on the front panel.
For example, press the CONFIG:MODE key.
2. Press the uppermost side key.

The information is displayed on the screen as shown in Figure 4-1:

- Version information:
 - Main System: Main software version
 - Sub System: Firmware version
- Result of the self test

```

WCA380 WIRELESS COMMUNICATION ANALYZER
Copyright (C) 2000 SONY/TEKTRONIX CORPORATION

Main System:
  Version:      3.11

Sub System:
  Version:      4.1
  Rom:          Pass
  Ram:          Pass
  A20:          Installed

Options:

```

Figure 4-1: Display of the self test results (view of upper left corner)

Self Calibration

There are four calibration routines:

- *Self gain-calibration* compensates the amplifier gain based on the internal signal generator.
- *IQ offset calibration* compensates the IQ signal offset between the signal source and the analyzer when inputting IQ signals.
- *Wide IQ balance calibration* compensates the DC component balance of IQ signals in the Wide mode.
- *Wide IQ full-calibration* performs the factory full-calibration for IQ signal balance in the Wide mode.

Self Gain-Calibration

When you boot the analyzer or when UNCAL (uncalibrated) is displayed during operation, perform self gain-calibration. An internal calibration routine calibrates amplifier gain based on an internal signal generator.

If you calibrate the analyzer when you boot it, let it warm up for more than 20 minutes and use the following procedure to calibrate it. The warm up period allows electrical performance of the analyzer to be stable.

During operation when the ambient temperature changes by more than $\pm 5^{\circ}\text{C}$ from the temperature at the previous calibration, UNCAL is displayed in the hardware status display area (see Figure 4–2), urging you to perform calibration.

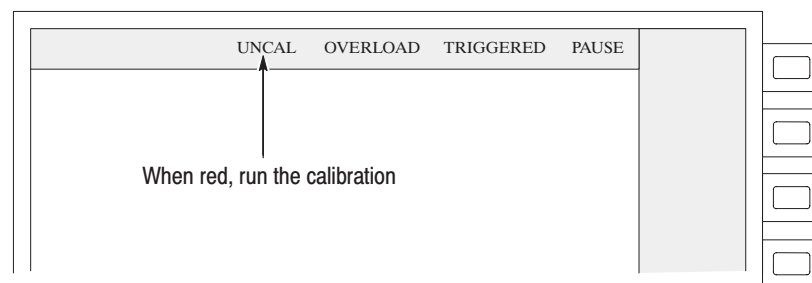


Figure 4–2: Displaying UNCAL

Use the following procedure to perform self gain-calibration.

NOTE. When you run calibration during signal acquisition, calibration is performed after the acquisition is completed.

1. Press the **UTILITY** key in the **CONFIG** area on the front panel. See Figure 4–3.
2. Press the **Util A/SelfCal** side key.
3. Press the **Gain Cal** side key.

The calibration runs. It takes several seconds to complete the process.

4. If you press the **AutoGainCal** side key to select **On**, calibration runs automatically when the analyzer becomes in the **UNCAL** state.

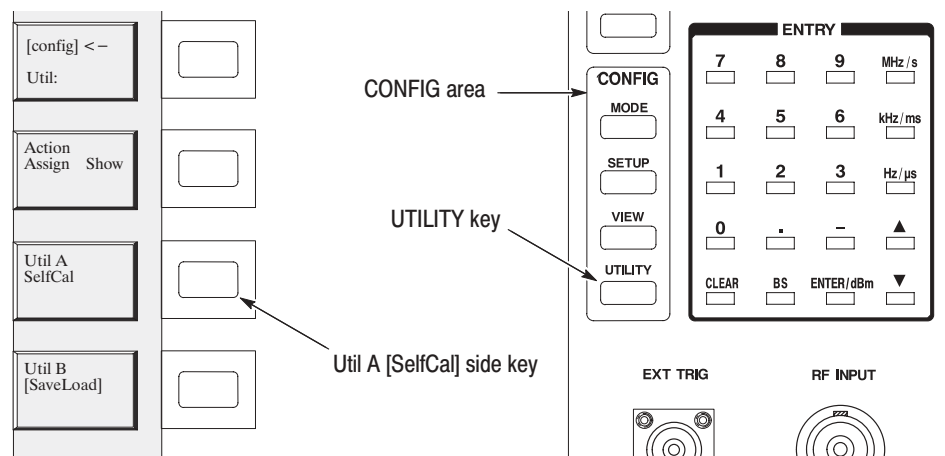


Figure 4-3: Running the self gain-calibration

IQ Offset Calibration

This calibration compensates the IQ signal offset between the signal source and the analyzer when inputting IQ signals.

NOTE. Before performing the following procedure, set the I/Q input signal level to zero.

1. Press the **UTILITY** key in the CONFIG area on the front panel. See Figure 4-3.
2. Press the **Util A / SelfCal** side key.
3. Press the **IQ Offset Cal** side key.

The calibration runs. It takes several dozen seconds to complete the process.

Wide IQ Balance Calibration

This calibration compensates the DC component balance of IQ signals in the Wide mode.

1. Press the **UTILITY** key in the CONFIG area on the front panel. See Figure 4-3.
2. Press the **Util A / SelfCal** side key.
3. Press the **Wide IQ Balance Cal** side key.

Calibration runs. It takes several seconds to complete the process.

Wide IQ Full Calibration

It performs the factory full calibration for IQ signal balance in the Wide mode.

1. Press the **MODE** key in the CONFIG area on the front panel. See Figure 4–4 below.
2. Press the **More...** side key twice.
3. Press the **Calibration** side key.
4. Press the **C** side key in the **VIEW** area.
5. Press the **Wide IQ Full Cal** side key.

Calibration runs. It takes several minutes to complete the process.

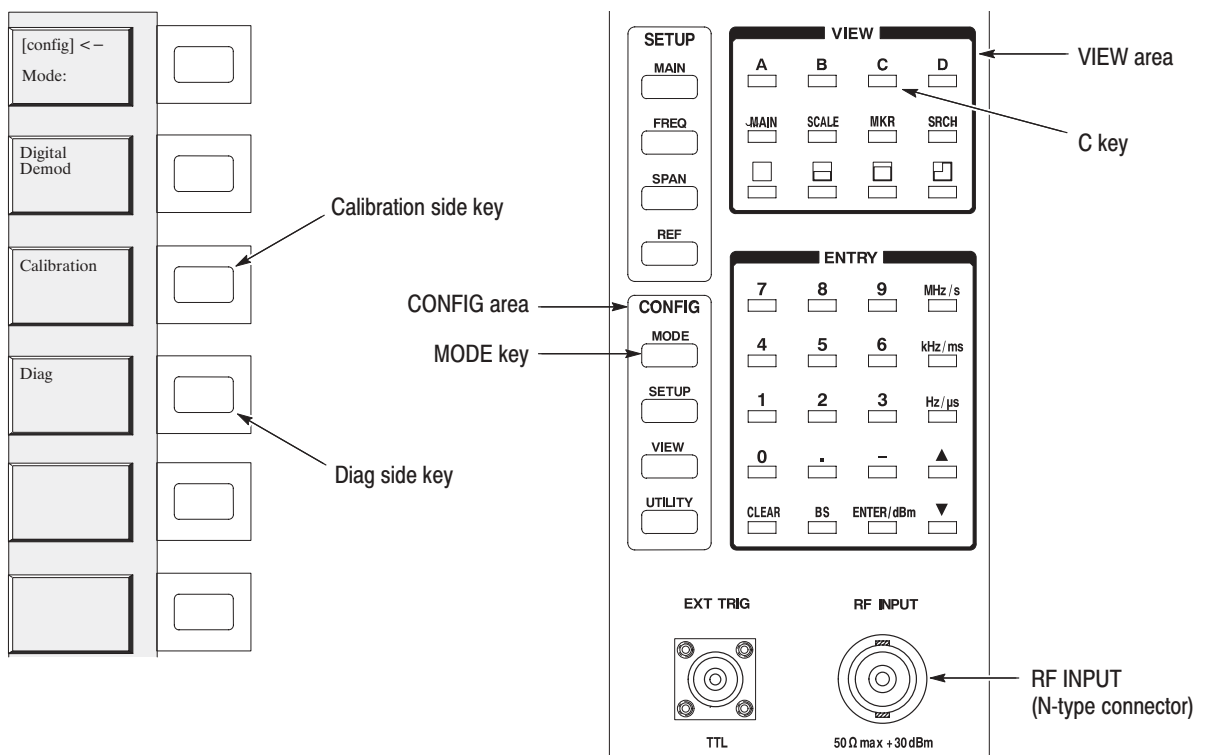


Figure 4-4: Running calibration and diagnostics

Diagnostics

You can run the internal diagnostic program to check hardware states. Table 4–2 shows test items and their descriptions.

Table 4–2: Internal diagnostic program

Item	Input band	Description
Memory	–	Check that data is written and read to/from the RAMs correctly.
Level	Baseband	Check that levels are measured correctly.
Overload		Check that overload is indicated correctly.
Freq Shift		Check that frequencies are measured correctly.
T-Domain		Check that data is continuous in the time domain.
F-Domain		Check that there is no abnormal spurious.
RF Level	RF (WCA330) RF1 (WCA380)	Check that levels are measured correctly.
RF Overload		Check that overload is indicated correctly.
RF Freq Shift		Check that frequencies are measured correctly.
RF T-Domain		Check that data is continuous in the time domain.
RF F-Domain		Check that there is no abnormal spurious.

Running the Diagnostics

This subsection explains how to run the diagnosis program.

Equipment Required	One 50 Ω BNC-N coaxial cable
Prerequisites	Power on the analyzer and allow a 20 minute warm-up before doing this procedure.

1. Connect the 50 Ω BNC-N coaxial cable to 10 MHz REF OUT (BNC-type connector) on the rear panel and RF INPUT (N-type connector) on the front panel.
2. Press the **MODE** key in the CONFIG area on the front panel. See Figure 4–4 on the left page.
3. Press the **More...** side key twice.
4. Press the **Diag** side key.
5. Press the **C** key in the VIEW area on the front panel.

6. Press the **Mode** side key to select an execution mode:

Interactive — Press the **Execute All** side key or the side key that corresponds to each test item to perform a test once.

Continuous — Press the **Execute All** side key or the side key that corresponds to each test item to perform a test repeatedly. To stop testing, press the **CLEAR** key.

StopOnFail — Press the **Execute All** side key or the side key that corresponds to each test item to perform a test until an error occurs. To stop testing, press the **CLEAR** key.

7. Press the **Execute All** side key to perform a test on every item. If you want to perform a test on each item, refer to Table 4–2 to press the side key that corresponds to each test item.

The execution results of the diagnosis program are displayed in the VIEW C (upper right window). The numbers of passes and fails are displayed for each test item. Passed items are shown with a green background and failed items with red.

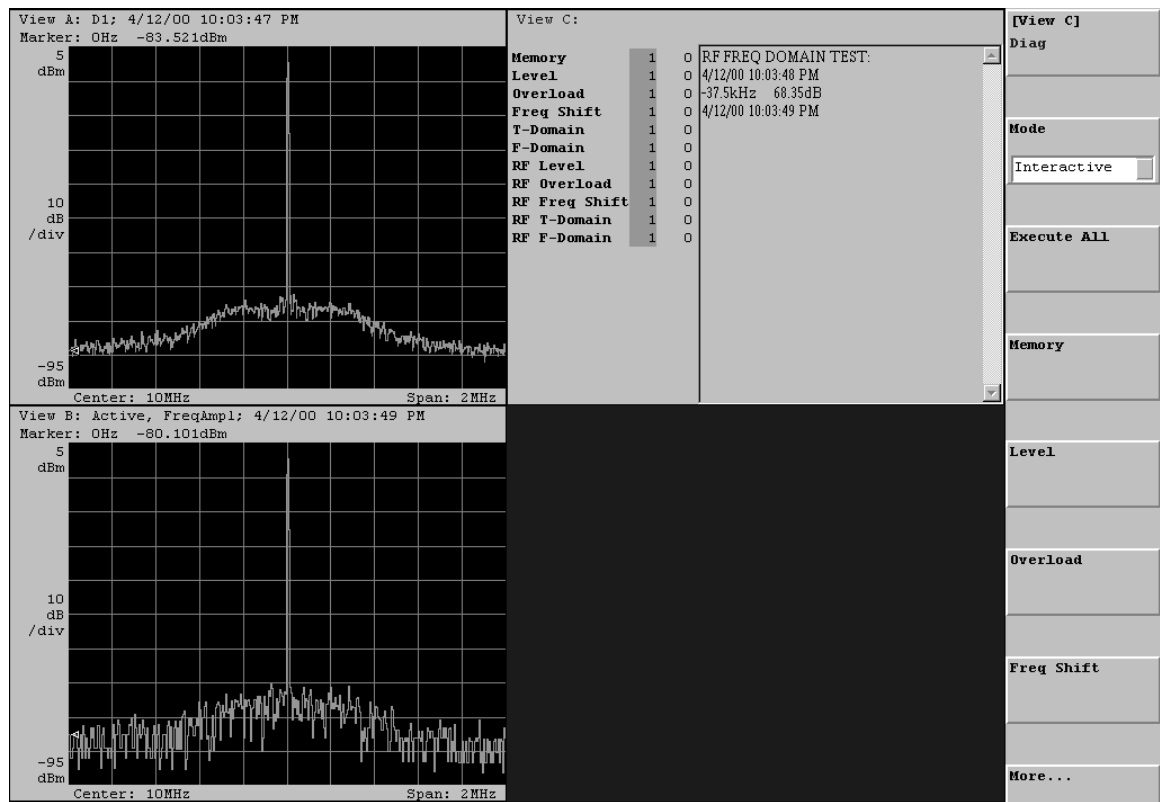


Figure 4-5: Execution results of diagnostic routines (View C)

Performance Tests

This section contains a collection of procedures for checking that the WCA330 and WCA380 analyzers perform as warranted.

There are two types of performance tests: *Auto Tests* and *Manual Tests*.

- *Auto Tests* use internal routines to verify that the analyzer functions and was adjusted properly. The Auto Tests are divided into two main groups by the input frequency band: *Baseband Tests* and *RF Tests*.
 - *Baseband Tests* check the analyzer performance in the baseband (up to 10 MHz).
 - *RF Tests* check the analyzer performance in the RF band (10 MHz to 3 GHz (WCA330) / 8 GHz (WCA380)). The RF Tests are divided into the subgroup Test A to F due to test signal connections.
- *Manual Tests* supplement the Auto Tests to verify the analyzer performance formally and report the test records.

Prerequisites

The tests in this section provide confirmation of instrument performance and functionality when the following requirements are met:

- The cabinet must be installed on the WCA330 or WCA380 analyzer.
- You must have performed and passed the procedures under *Self Tests*, found on page 4–3.
- A signal-path compensation must have been done within the recommended calibration interval and at a temperature within $\pm 3^{\circ}$ C of the present operating temperature. (If at the time you did the prerequisite *Self Tests*, the temperature was within the limits just stated, consider this prerequisite met.)
- The WCA330/WCA380 analyzer must have been last adjusted at an ambient temperature between $+20^{\circ}$ C and $+30^{\circ}$ C, must have been operating for a warm-up period of at least 20 minutes, and must be operating at an ambient temperature between $+10^{\circ}$ C and $+40^{\circ}$ C. (The warm-up requirement is usually met in the course of meeting the Self Tests prerequisites listed above.)
- The frequency counter (refer to page 4–13) must have been operating for a warm-up period of at least 24 hours.
- The setup files (Item 21 in Table 4–3) must be loaded to the waveform generator (Item 6). The setup files contain the test settings and waveforms. For the installation procedure, refer to *Installing Setup Files on the Waveform Generator* on page 5–14.
- The SG and MSG flatness floppy disks must be prepared (Item 19 and 20 in Table 4–3). For the procedure to create or update the flatness correction files, refer to *Preparing the Flatness Correction File* on page 5–15.

Equipment Required

These procedures use external, traceable signal sources to directly check warranted characteristics. The required equipment list follows this introduction.

Table 4–3: Test equipment

Item number and description	Minimum requirements	Example	Purpose
1. Frequency counter	Frequency range: 10 MHz; Aging rate: $<5 \times 10^{-10}$ /day; Accuracy: <0.01 ppm at 10 MHz	Anritsu MF1603A option 03	Checking the reference output frequency accuracy
2. Signal generator	Frequency range: 10 kHz to 3 GHz; Variable amplitude from -70 dBm to $+13$ dBm into 50Ω ; Accuracy: $<\pm 1$ dB; Function: FM	HP 8648C/D option 1E5 ¹	Checking RF flatness
3. Signal generator	Output: ≥ -10 dBm at 25 MHz; SSB phase noise: <-110 dBc/Hz at 10 kHz offset	Anritsu MG3642A	Checking spectrum purity
4. Signal generator	Frequency: 2GHz; Output: ≥ -10 dBm; Digital modulation: QPSK; Symbol rate: 4.096 M/s	Rohde & Schwartz SMIQ option 03	Checking digital demodulation accuracy
5. Microwave signal generator	Frequency range: 10 MHz to 8 GHz; Output level: -4 dBm to $+10$ dBm; Accuracy: $<\pm 1$ dB	HP 83711B ¹ or Anritsu 69053A ¹	Checking RF flatness
6. Waveform generator	Arbitrary waveform; Two output channels; Sampling frequency: 50 kHz to 1 GHz; Amplitude range: 20 mV to 2 V	Sony/Tektronix AWG520 ¹	Software-based adjustments
7. RF power meter	1 MHz to 8 GHz	HP E4418B	Checking reference level accuracy
8. RF power sensor	10 MHz to 8 GHz; RF Flatness: <3 %; Uncertainty of calibration factor data: <2 % (RSS)	HP E4412A	Checking reference level accuracy in the RF band
9. RF power sensor	1 MHz to 25 MHz; RF Flatness: <3 %; Uncertainty of calibration factor data: <2 % (RSS)	HP 8482A	Checking reference level accuracy in the baseband
10. RF step attenuator	10 dB step; Accuracy: <3 %; Range: ≥ 1 MHz	HP 8496B	Checking reference level accuracy
11. Power combiner	Range: 500 MHz to 2 GHz; Isolation: >18 dB; Insertion loss: <1.0 dB	Mini-Circuits ZAPD-21	Checking 2-signal 3rd-distortion

Table 4-3: Test equipment (Cont.)

Item number and description	Minimum requirements	Example	Purpose
12. BNC cable	50 Ω , 36 in, male to male BNC connectors	Tektronix part number 012-1341-00	Signal interconnection
13. BNC-SMB cable	50 Ω , 90 in, male BNC to male SMB connectors		Signal interconnection
14. N-N cable	50 Ω , 36 in, male to male N connectors		Signal interconnection
15. N-SMA cable (Three required)	50 Ω , 36 in, male N to male SMA connectors		Signal interconnection
16. GPIB cable	2m, double-shielded	Tektronix 012-0991-00	Software-based tests
17. BNC-N adapter	Female BNC to male N connectors	Standard accessory Tektronix part number 103-0045-00	Signal interconnection
18. Terminator	Impedance: 50 Ω ; connectors: female BNC input, male BNC output	Tektronix part number 011-0049-01	Signal termination for checking frequency accuracy
19. SG flatness floppy disk	Created or updated with the procedures described on page 5-15	3.5 inch, 720 K or 1.44 Mbyte, DOS-compatible floppy disk	Storing flatness correction data for the signal generator (Item 2)
20. MSG flatness floppy disk	Created or updated with the procedures described on page 5-15	3.5 inch, 720 K or 1.44 Mbyte, DOS-compatible floppy disk	Storing flatness correction data for the microwave signal generator (Item 5)
21. AWG520 setup disk (CD-ROM)	Contain the setting and waveform files for the analyzer calibration	Tektronix part number 062-A250-00	Setting up the AWG520 waveform generator (Item 6)

¹ Use this instrument only. The performance tests specify that the analyzer controls this instrument over the GPIB.

Auto Test Procedures

This section describes the performance tests that are done automatically by executing the internal test routines. The performance tests are divided into two main categories by the input frequency bands:

- *Baseband tests* check the Baseband (up to 10 MHz) performance of the analyzer by running the internal test routines. The test items are listed in Table 4-4.
- *RF tests* check the RF band (10 MHz to 3 GHz (WCA330) / 8 GHz (WCA380)) performance of the analyzer by running the internal test routines. The tests are divided into Test A to F due to test signal connections. The test items are listed in Table 4-5.

Table 4-4: Baseband tests

Title	Description	Spec.
Memory test	<ul style="list-style-type: none"> ■ Checks the RAMs that store captured data. 	
Attenuator test	<ul style="list-style-type: none"> ■ Checks that the baseband reference level satisfies the specification. ■ Checks that the overload detector works correctly. 	1-7
Span and center frequency test	<ul style="list-style-type: none"> ■ Checks that the span setting operates correctly. ■ Checks that the center frequency setting operates correctly. 	
Frame update interval test	<ul style="list-style-type: none"> ■ Checks that the frame update interval setting operates correctly. ■ Checks that FFT of both 256 and 1024 points works correctly. 	
Internal trigger test	<ul style="list-style-type: none"> ■ Checks that the frequency-domain event trigger works correctly. ■ Checks that the frequency resolution satisfies the specification. 	1-8
External trigger test	<ul style="list-style-type: none"> ■ Checks that the external trigger works correctly. ■ Checks that the delay from the external trigger satisfies the specification. 	1-8
Time-domain trigger test	<ul style="list-style-type: none"> ■ Checks that the time-domain trigger works correctly. ■ Checks that the trigger level satisfies the specification. 	1-8
Flatness and aliasing test	<ul style="list-style-type: none"> ■ Checks that the level accuracy within the baseband satisfies the specification. ■ Checks that the alias suppression ratio satisfies the specification. 	1-7
FM zoom test	<ul style="list-style-type: none"> ■ Checks that the zoom functions correctly. ■ Checks that the frequency modulation (FM) demodulation functions correctly. 	
Key test	<ul style="list-style-type: none"> ■ Checks that the front panel key works correctly. 	

Table 4-5: RF tests

Title	Description	Spec.
Test A	Checks RF (WCA330) / RF1 (WCA380) band performance.	
Self gain-calibration test	<ul style="list-style-type: none"> ■ Checks that the self gain-calibration works correctly. ■ Checks that the level accuracy satisfies the specification after the calibration. 	1-7
RF reference level test	<ul style="list-style-type: none"> ■ Checks that the reference level accuracy satisfies the specification at 1.5 GHz. ■ Tests with the input signal that is +5 dB lower than the reference level. 	1-7
IF flatness test	<ul style="list-style-type: none"> ■ Checks that the in-band level accuracy of the Normal and HiRes IF modes satisfies the specification. 	1-7
RF flatness test	<ul style="list-style-type: none"> ■ Checks the in-band level accuracy of the RF (WCA330) or RF1 (WCA380) bands satisfies the specification. 	1-7
RF residual response test	<ul style="list-style-type: none"> ■ Checks that the display spectrum with no input satisfies the specification. 	
Average noise test	<ul style="list-style-type: none"> ■ Checks that the average display noise level satisfies the specification. 	
RF zoom test	<ul style="list-style-type: none"> ■ Checks that the zoom functions correctly in the RF mode. ■ Checks that the time-domain data is acquired continuously. 	
RF spurious response test	<ul style="list-style-type: none"> ■ Checks that the spurious level when inputting a signal satisfies the specification. 	
Test B	Checks the Wide IF mode performance.	
Wide IF reference level test	<ul style="list-style-type: none"> ■ Checks the reference level accuracy satisfies the specification in the Wide IF mode. ■ Tests with the input signal that is +5 dB lower than the reference level. 	1-7
Wide IF flatness test	<ul style="list-style-type: none"> ■ Checks that the in-band flatness satisfies the specification. 	1-7
Wide IF residual response test	<ul style="list-style-type: none"> ■ Checks that the display spectrum with no input satisfies the specification. 	
Sideband spurious response test	<ul style="list-style-type: none"> ■ Checks that the sideband level when inputting a signal satisfies the specification. 	
Wide IF zoom test	<ul style="list-style-type: none"> ■ Checks that the zoom functions correctly in the Wide IF mode. ■ Checks that the time-domain data is acquired continuously. 	
Test C (WCA380 only)	Checks the RF2 to RF4 band performance.	
RF3/4 reference level test	<ul style="list-style-type: none"> ■ Checks that the reference level accuracy satisfies the specification at 5 GHz (RF3) and 6.5 GHz (RF4). ■ Tests with the input signal that is +5 dB lower than the reference level. 	1-7
RF2 flatness test	<ul style="list-style-type: none"> ■ Checks that the in-band level accuracy for the RF2 band satisfies the specification. 	1-7
RF3 flatness test	<ul style="list-style-type: none"> ■ Checks that the in-band level accuracy for the RF3 band satisfies the specification. 	1-7
RF4 flatness test	<ul style="list-style-type: none"> ■ Checks that the in-band level accuracy for the RF4 band satisfies the specification. 	1-7
RF2 spurious response test	<ul style="list-style-type: none"> ■ Checks that the spurious level for the RF2 input signal satisfies the specification. 	
RF3 spurious response test	<ul style="list-style-type: none"> ■ Checks that the spurious level for the RF3 input signal satisfies the specification. 	
RF4 spurious response test	<ul style="list-style-type: none"> ■ Checks that the spurious level for the RF4 input signal satisfies the specification. 	

Table 4-5: RF tests (Cont.)

Title	Description	Spec.
Test D	Checks the trigger in the Wide IF mode and the digital demodulation performance.	
Wide IF trigger test	■ Checks that the trigger functions correctly in the Wide IF mode.	1-8
Digital demodulation test 1	■ Checks that the EVM accuracy of digital demodulation satisfies the specification for the Normal IF mode.	1-8
Digital demodulation test 2	■ Checks that the EVM accuracy of digital demodulation satisfies the specification for the Wide IF mode.	1-8
Test E	Checks the 2-signal 3rd-distortion.	
2-signal 3rd-distortion test	■ Checks that the 2-signal 3rd-distortion satisfies the specification.	1-7
Test F	Checks the IQ input characteristics.	
IQ input level test	■ Checks that the reference level accuracy for the IQ input satisfies the specification.	1-7

STOP. These procedures extend the confidence level provided by the basic procedures described on page 4-3. The basic procedures should be done first, then these procedures may be performed if desired.

Executing the Auto Tests

The auto tests are done by running the internal test routines. Use the side keys to run the tests. See Figure 4–6. The results are shown in View C. The detail procedures start on the next page.

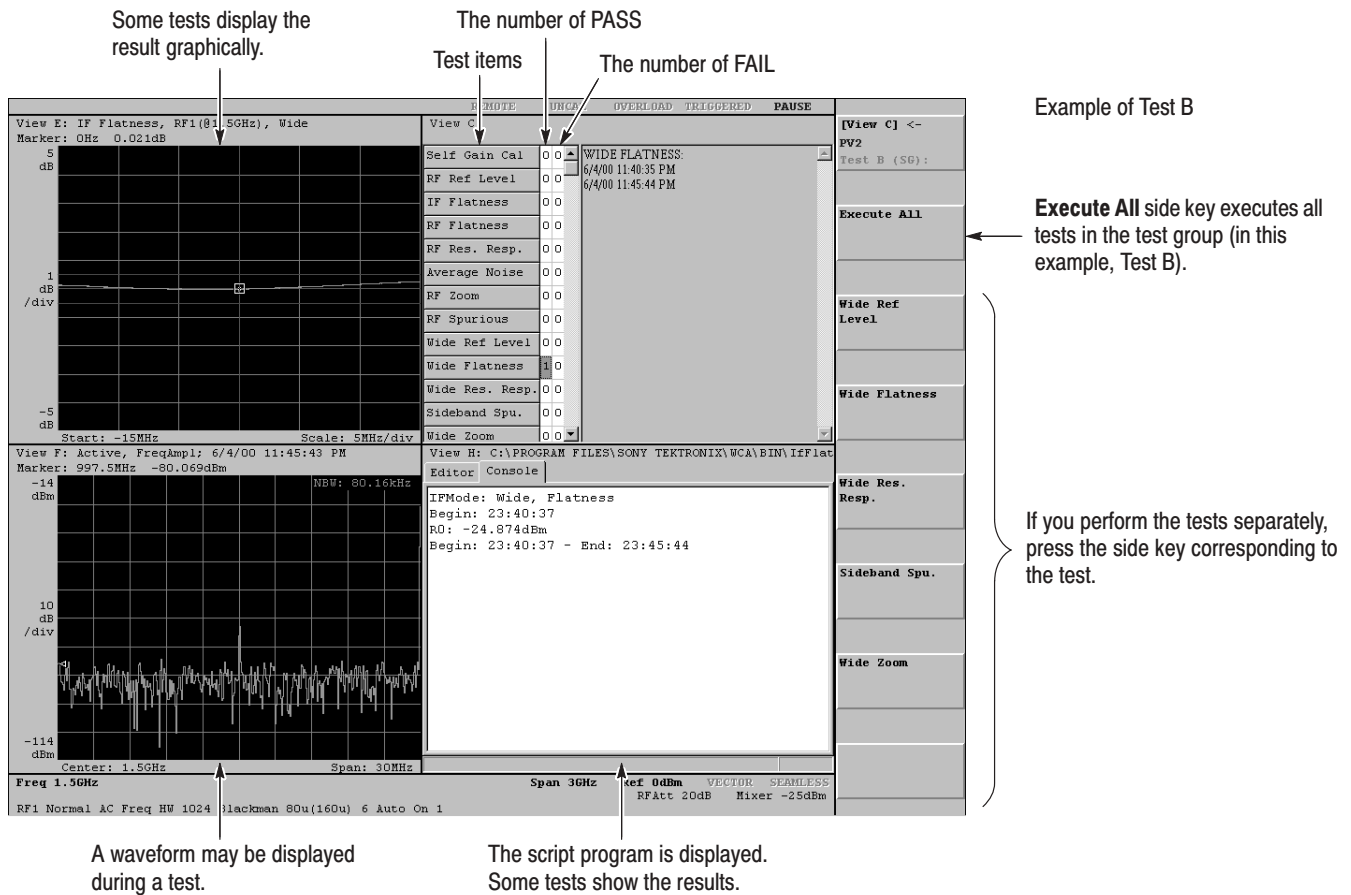


Figure 4–6: Executing the performance test routines

Retrieving the Test Results. The test results are shown in View C (upper right window) with Pass/Fail and View H (lower right window) with the measurement data. After you have done all or one of the auto tests, the RF test results are written in this file:

PV2.log under the directory *C:\Program Files\SONY Tektronix\wca\Sys\Log*

This file simply adds the new test data i.e. does not overwrite the previous data. You can retrieve test data by searching the test title (e.g. “2-Tone Distortion”) in a text editor such as Notepad.

Baseband Tests

This section describes the Baseband test procedures. Table 4–6 lists the test titles and menu items. You can do the all tests automatically by running the internal routines except for the 10 MHz reference output test that is done manually.

Table 4–6: Baseband tests

Test title	Menu item
Memory test	Memory
Attenuator test	Att
Span and center frequency test	Span / CF
Frame update interval test	Frame Update
Internal trigger test	Int Trigger
External trigger test	Ext Trigger
Time-domain trigger test	Time Trigger
Flatness and aliasing test	Flatness / Aliasing
FM zoom test	FM Zoom
Key test	Key

The baseband tests in Table 4–6 are done automatically by running the internal routines with the following procedure.

Equipment Required	One waveform generator (Item 6) One 50 Ω BNC coaxial cable (Item 12) One 50 Ω BNC-SMB coaxial cable (Item 13) One female BNC to male N adapter (Item 17) One GPIB cable (Item 16)
Prerequisites	Refer to page 4–12. The setup files must be loaded to the waveform generator.

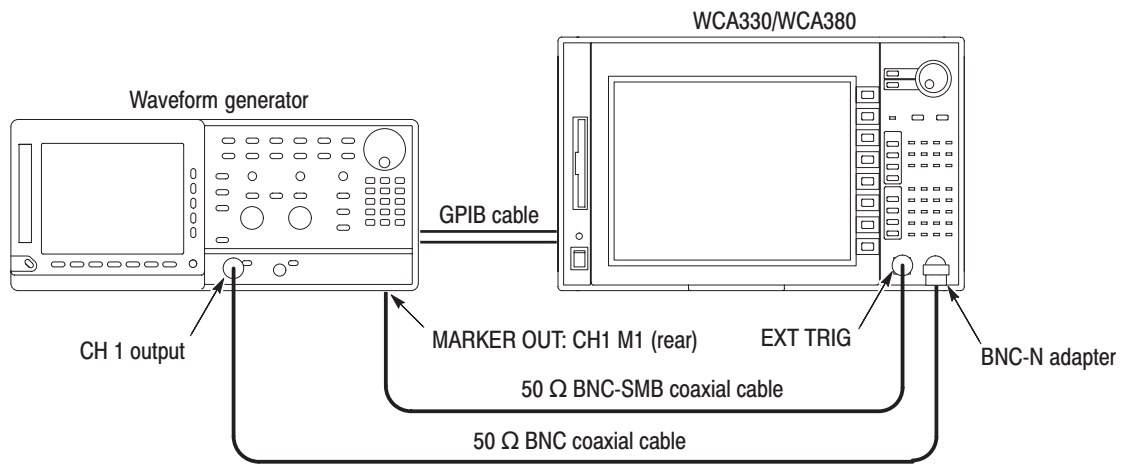


Figure 4–7: Initial test hookup

1. *Install the test hookup and preset the instrument controls:*
 - a. Power off the WCA330/WCA380 analyzer and waveform generator.
 - b. Connect the generator CH 1 output through a 50 Ω BNC coaxial cable and a BNC-N adapter to the analyzer **RF INPUT**. See Figure 4–7.
 - c. Connect the generator **MARKER OUT: CH1 M1** SMB connector on the rear panel through a 50 Ω BNC-SMB coaxial cable to the analyzer **EXT TRIG** BNC input connector. See Figure 4–7.
 - d. Connect the analyzer and the generator with a GPIB cable.
 - e. Power on the analyzer and the generator.
 - f. Set the GPIB address of the generator to 3.

2. *Let the instruments warm up:* Allow a 20 minute warm-up period before you go to the next step.
3. *Load the performance verification setup file:*
 - a. Press **CONFIG:MODE** → **Load From File (*.CFG)**.
The directory and file lists are displayed.
 - b. Open the directory *C:\Program Files\SONY Tektronix\wca\Bin*.
 - c. Select the file *PVI.cfd* and Press **OK**.

The setup file is loaded.
4. Press **VIEW:C** to display the test menu.
5. Press the **Mode** side key to select an execution mode:

Interactive — Performs the test once by pressing the **Execute All** side key or the side key that corresponds to each test item.

Continuous — Performs the test repeatedly by pressing the **Execute All** side key or the side key that corresponds to each test item. To stop testing, press the **CLEAR** key.

StopOnFail — Performs the test until an error occurs by pressing the **Execute All** side key or the side key that corresponds to each test item. To stop testing, press the **CLEAR** key.
6. Press the **Execute All** side key to perform a test on every item. If you want to perform a test on each item, refer to Table 4–6 to press the side key that corresponds to each test item.

All of the tests are executed automatically, except for the Key test. When running the Key test, press any key on the front panel and make sure that the correct key name is displayed in View C.

The results are shown in View C. The numbers of Passes or Fails are indicated with the background color green or red, respectively. Some tests show the results graphically in View A.

RF Tests

The RF tests are divided into Test A to F due to test signal connections. The details are described in order below.

Test A Test A uses the signal generator to check the RF performance.

Table 4-7: RF tests — Test A

Test title	Menu item
Self gain-calibration test	Self Gain Cal
RF reference level test	RF Ref Level
IF flatness test	IF Flatness
RF flatness test	RF Flatness
RF residual response test	RF Res. Resp.
Average noise test	Average Noise
RF zoom test	RF Zoom
RF spurious response test	RF Spurious

Equipment Required	One signal generator (Item 2) One 50 Ω N-N coaxial cable (Item 14) One GPIB cable (Item 16) One SG flatness floppy disk (Item 19)
Prerequisites	Refer to page 4-12

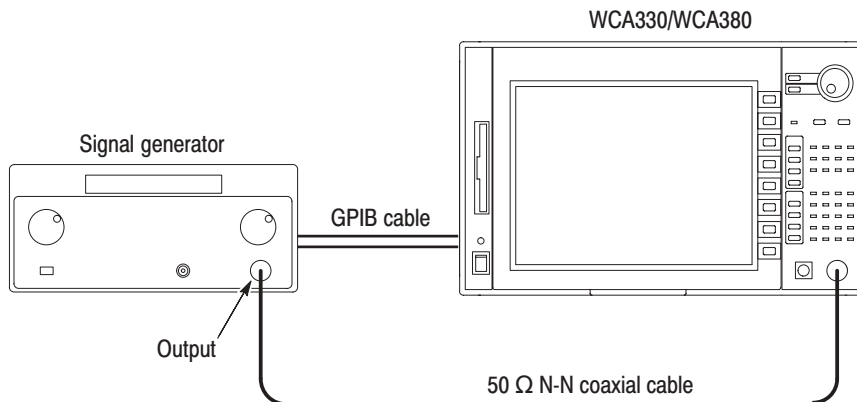


Figure 4-8: Initial test hookup

1. *Install the test hookup and preset the instrument controls:*
 - a. Power off the WCA330/WCA380 analyzer and the signal generator.
 - b. Connect the generator output through a 50 Ω N-N coaxial cable to the analyzer **RF INPUT**. See Figure 4–8.
 - c. Connect the analyzer and the generator with a GPIB cable.
 - d. Power on the analyzer and the generator.
 - e. Set the GPIB address of the generator to 1.
 - f. Insert the SG flatness floppy disk (Item 19) to the floppy disk drive of the analyzer.
2. *Load the performance verification setup file:*
 - a. Press **CONFIG:MODE** → **Load From File (*.CFG)**.
The directory and file lists are displayed.
 - b. Open the directory *C:\Program Files\SONY Tektronix\wca\Bin*.
 - c. Select the file *PV2.cfd* and Press **OK**.

The setup file is loaded.
3. Press **VIEW:C** → **Test A (SG)...** to display the test menu.

NOTE. *Do not use the Spurious Setup... submenu in the Test A menu: it represents factory troubleshooting and calibration aids not intended for general use.*

4. *Let the instruments warm up:* Allow a 20 minute warm-up period before you go to the next step.
5. Press the **Execute All** side key to perform tests on every item. If you want to perform a test on each item, refer to Table 4–7 to press the side key that corresponds to each test item.

Test B Test B uses the signal generator to check the Wide IF mode performance.

Table 4-8: RF tests — Test B

Test title	Menu item
Wide IF reference level test	Wide Ref Level
Wide IF flatness test	Wide Flatness
Wide IF residual response test	Wide Res. Resp.
Sideband spurious response test	Sideband Spu.
Wide IF zoom test	Wide Zoom

Equipment Required	One signal generator (Item 2) One 50 Ω N-N coaxial cable (Item 14) One GPIB cable (Item 16) One SG flatness floppy disk (Item 19)
Prerequisites	See page 4-12

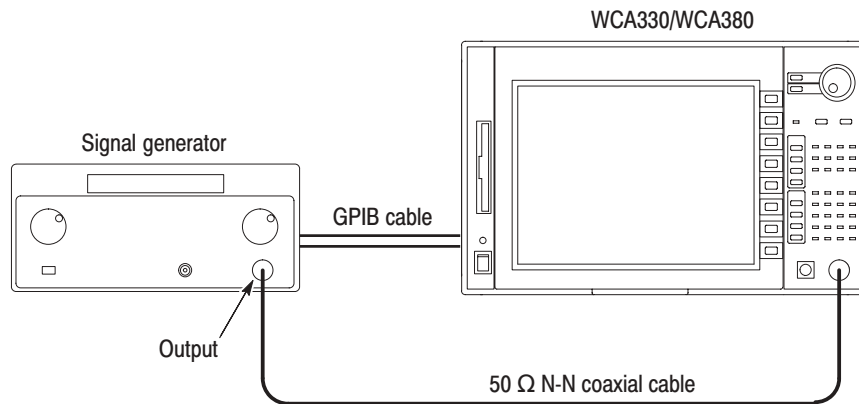


Figure 4-9: Initial test hookup

1. *Install the test hookup and preset the instrument controls:*
 - a. Power off the WCA330/WCA380 analyzer and the signal generator.
 - b. Connect the generator output through a 50 Ω N-N coaxial cable to the analyzer **RF INPUT**. See Figure 4–9.
 - c. Connect the analyzer and the generator with a GPIB cable.
 - d. Power on the analyzer and the generator.
 - e. Set the GPIB address of the generator to 1.
 - f. Insert the SG flatness floppy disk (Item 19) to the floppy disk drive of the analyzer.
2. *Load the performance verification setup file:*
 - a. Press **CONFIG:MODE** → **Load From File (*.CFG)**.
The directory and file lists are displayed.
 - b. Open the directory *C:\Program Files\SONY Tektronix\wca\Bin*.
 - c. Select the file *PV2.cfd* and Press **OK**.

The setup file is loaded.
3. Press **VIEW:C** → **Test B (SG)...** to display the test menu.
4. *Let the instruments warm up:* Allow a 20 minute warm-up period before you go to the next step.
5. Press the **Execute All** side key to perform a test on every item. If you want to perform a test on each item, refer to Table 4–8 to press the side key that corresponds to each test item.

**Test C
(WCA380 Only)**

Test C uses the microwave signal generator to check the RF 2 to 4 performance.

Table 4-9: RF tests — Test C

Test title	Menu item
RF3/4 reference level test	RF3/4 Ref Level
RF2 flatness test	RF2 Flatness
RF3 flatness test	RF3 Flatness
RF4 flatness test	RF4 Flatness
RF2 spurious response test	RF2 Spurious
RF3 spurious response test	RF3 Spurious
RF4 spurious response test	RF4 Spurious

Equipment Required	One microwave signal generator (Item 5) One 50 Ω N-N coaxial cable (Item 14) One GPIB cable (Item 16) One MSG flatness floppy disk (Item 20)
Prerequisites	See page 4-12

1. *Install the test hookup and preset the instrument controls:*
 - a. Power off the WCA380 analyzer and the signal generator.
 - b. Connect the generator output through a 50 Ω N-N coaxial cable to the analyzer **RF INPUT**. See Figure 4-10.

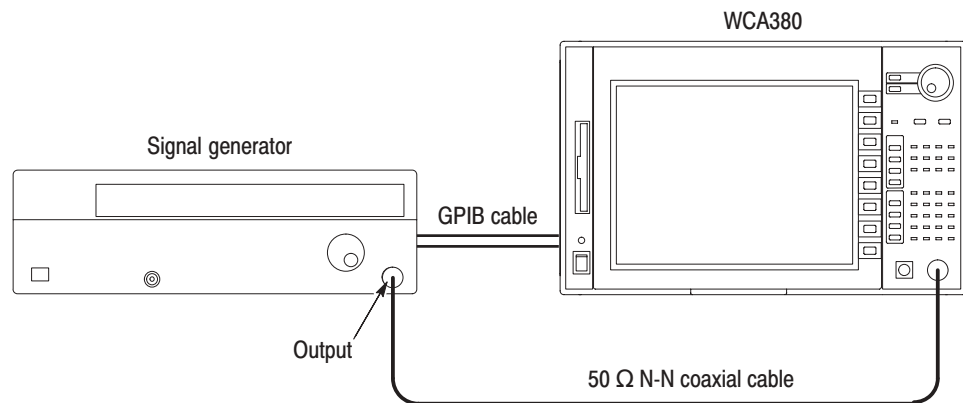


Figure 4-10: Initial test hookup

- c. Connect the analyzer and the generator with a GPIB cable.
 - d. Power on the analyzer and the generator.
 - e. Set the GPIB address of the generator to 5.
 - f. Insert the MSG flatness floppy disk (Item 20) to the floppy disk drive of the analyzer.
2. *Load the performance verification setup file:*
 - a. Press **CONFIG:MODE** → **Load From File (*.CFG)**.
The directory and file lists are displayed.
 - b. Open the directory *C:\Program Files\SONY Tektronix\wca\Bin*.
 - c. Select the file *PV2.cfd* and Press **OK**.

The setup file is loaded.
 3. Press **VIEW:C** → **Test C (MSG)...** to display the test menu.
 4. With the **RF2-4 SG** side key, select **HP** or **Anritsu** for the generator connected to the analyzer.

NOTE. Do not use the RF2-4 Spu. Setup... submenu in the Test A menu: it represents factory troubleshooting and calibration aids not intended for general use.

5. *Let the instruments warm up:* Allow a 20 minute warm-up period before you go to the next step.
6. Press the **Execute All** side key to perform a test on every item. If you want to perform a test on each item, refer to Table 4-9 to press the side key that corresponds to each test item.

Test D Test D uses the waveform generator to check the wide mode trigger and digital demodulation performance.

Table 4-10: RF tests — Test D

Test title	Menu item
Wide trigger test	Wide Trigger
Digital demodulation test 1	Digital Demod 1
Digital demodulation test 2	Digital Demod 2

Equipment Required	One waveform generator (Item 6) One 50 Ω BNC-BNC coaxial cable (Item 14)
Prerequisites	Refer to page 4-12. The setup files must be loaded to the waveform generator.

1. *Install the test hookup and preset the instrument controls:*
 - a. Power off the WCA330/WCA380 analyzer and waveform generator.
 - b. Connect the generator CH 1 output through a 50 Ω BNC coaxial cable and a BNC-N adapter to the analyzer **RF INPUT**. See Figure 4-11.

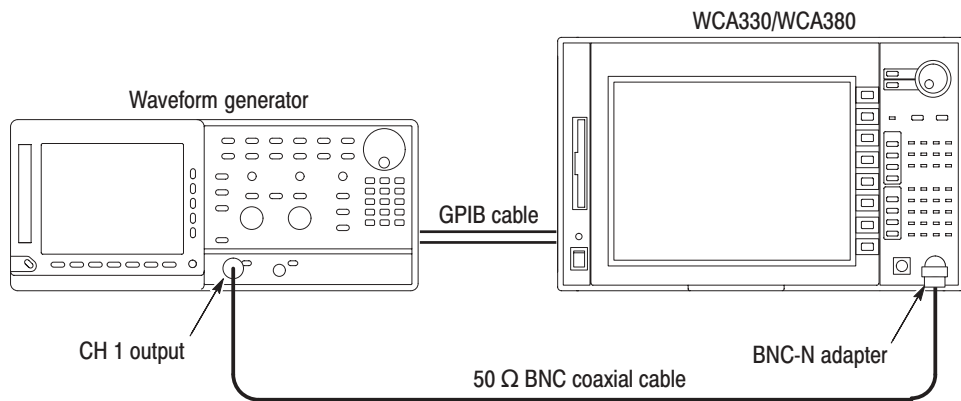


Figure 4-11: Initial test hookup

- c. Connect the analyzer and the generator with a GPIB cable.
- d. Power on the analyzer and the generator.
- e. Set the GPIB address of the generator to 3.

2. *Load the performance verification setup file:*
 - a. Press **CONFIG:MODE** → **Load From File (*.CFG)**.
The directory and file lists are displayed.
 - b. Open the directory *C:\Program Files\SONY Tektronix\wca\Bin*.
 - c. Select the file *PV2.cfd* and Press **OK**.

The setup file is loaded.
3. Press **VIEW:C** → **Test D (AWG)...** to display the test menu.
4. *Let the instruments warm up:* Allow a 20 minute warm-up period before you go to the next step.
5. Press the **Execute All** side key to perform a test on every item. If you want to perform a test on each item, refer to Table 4–10 to press the side key that corresponds to each test item.

Test E Test E uses the signal generator and the microwave signal generator to check the 3rd intermodulation distortion.

Table 4-11: RF tests — Test E

Test title	Menu item
2-signal 3 rd -distortion test	2-Tone Distortion

Equipment Required	One signal generator (Item 2) One microwave signal generator (Item 5) One power combiner (Item 11) Three 50 Ω N-SMA coaxial cables (Item 15) Two GPIB cables (Item 16)
Prerequisites	Refer to page 4-12.

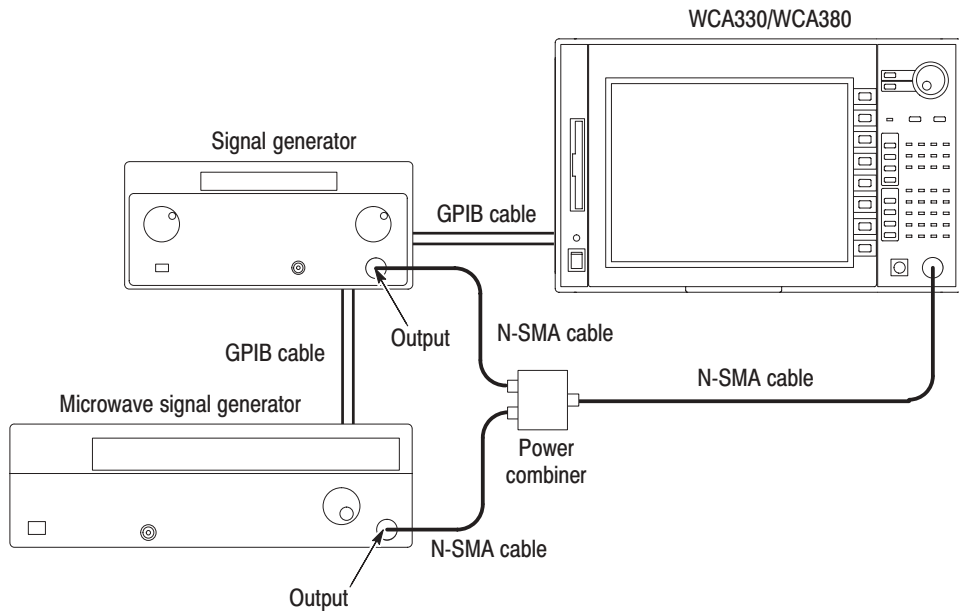


Figure 4-12: Initial test hookup

1. *Install the test hookup and preset the instrument controls:*
 - a. Power off the WCA330/WCA380 analyzer and two signal generators.
 - b. Connect each generator output through a 50 Ω N-SMA coaxial cable to each power combiner input. See Figure 4–12.
 - c. Connect the power combiner output through a 50 Ω N-SMA coaxial cable to the analyzer **RF INPUT**. See Figure 4–12 again.
 - d. Connect the analyzer and the generators with GPIB cables.
 - e. Power on the analyzer and the generators.
 - f. Set the GPIB address of the signal generator to 1.
 - g. Set the GPIB address of the microwave signal generator to 5.
2. *Load the performance verification setup file:*
 - a. Press **CONFIG:MODE** → **Load From File (*.CFG)**.
The directory and file lists are displayed.
 - b. Open the directory *C:\Program Files\SONY Tektronix\wca\Bin*.
 - c. Select the file *PV2.cfd* and press **OK**.

The setup file is loaded.
3. Press **VIEW:C** → **Test E (SG, MSG)...** to display the test menu.
4. With the **RF2–4 SG** side key, select **HP** or **Anritsu** for the microwave signal generator connected to the analyzer.
5. *Let the instruments warm up:* Allow a 20 minute warm-up period before you go to the next step.
6. Press the **Execute All** side key to perform a test on every item. If you want to perform a test on each item, refer to Table 4–11 to press the side key that corresponds to each test item.

Test F Test F uses the waveform generator to check the IQ characteristics.

Table 4-12: RF tests — Test F

Test title	Menu item
IQ input level test	IQ Input Level

Equipment Required	One waveform generator (Item 6) One 50 Ω BNC-BNC coaxial cable (Item 14)
Prerequisites	Refer to page 4-12. The setup files must be loaded to the waveform generator.

1. *Install the test hookup and preset the instrument controls:*
 - a. Power off the WCA330/WCA380 analyzer and the waveform generator.
 - b. Connect the CH 1 output of the generator through a 50 Ω BNC coaxial cable to the **I INPUT** connector on the analyzer rear panel. See Figure 4-13.

NOTE. Make sure that the two BNC cables for I and Q signal connections have the same length.

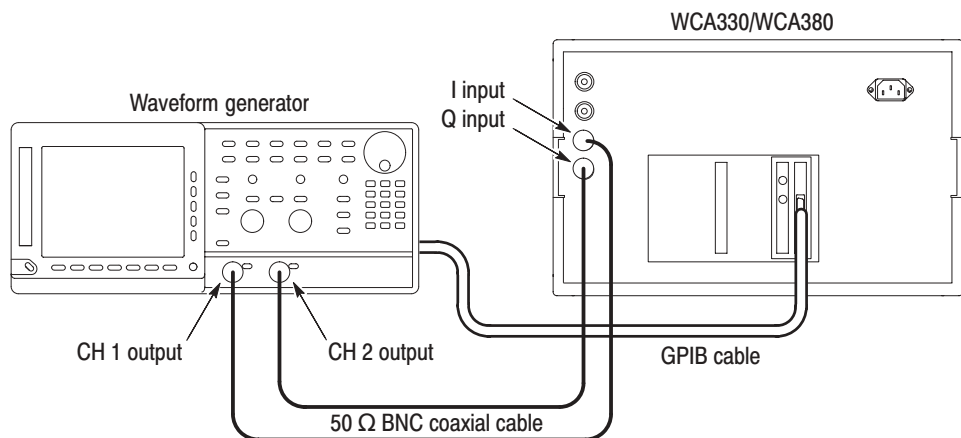


Figure 4-13: Initial test hookup

- c. Connect the CH 2 output of the generator through a 50 Ω BNC coaxial cable to the **Q INPUT** connector on the analyzer rear panel. See Figure 4–13.
 - d. Connect the analyzer and the generator with a GPIB cable.
 - e. Power on the analyzer and the generator.
 - f. Set the GPIB address of the generator to 3.
2. *Load the performance verification setup file:*
 - a. Press **CONFIG:MODE** → **Load From File (*.CFG)**.
The directory and file lists are displayed.
 - b. Open the directory *C:\Program Files\SONY Tektronix\wca\Bin*.
 - c. Select the file *PV2.cfd* and Press **OK**.

The setup file is loaded.
3. Press **VIEW:C** → **Test F (AWG)...** to display the test menu.
4. *Let the instruments warm up:* Allow a 20 minute warm-up period before you go to the next step.
5. Press the **Execute All** side key to perform a test on every item. If you want to perform a test on each item, refer to Table 4–12 to press the side key that corresponds to each test item.

Manual Test Procedures

This section provides the manual test procedures for checking that the analyzer performs as warranted.

Table 4-13: Manual tests

Title	Page	Spec.
10 MHz reference output test	4-35	1-6
Center frequency setting test	4-36	1-6
Spectrum purity test	4-38	1-6
Reference level accuracy test	4-42	1-7
Digital demodulation accuracy test	4-51	1-8

10 MHz Reference Output Test

This procedure checks that the output frequency from the **10 MHz REF OUTPUT** connector on the rear panel, is within the specified range for the analyzer.

Equipment Required	One frequency counter (Item 1) One 50 Ω BNC coaxial cable (Item 12) One 50 Ω terminator (Item 18)
Prerequisites	Refer to page 4-12.

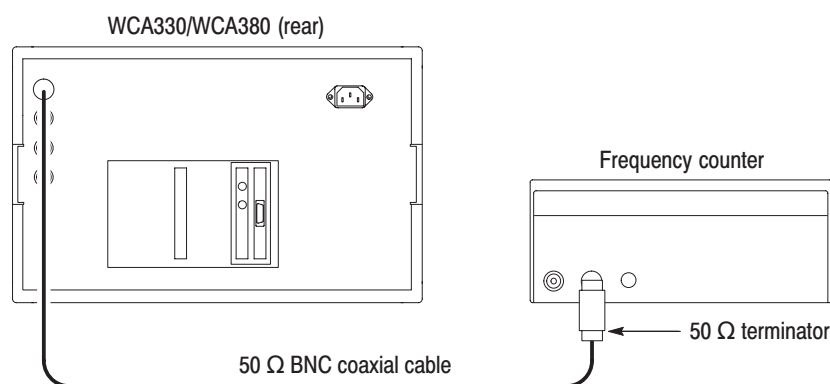


Figure 4-14: Initial test hookup

1. *Install the test hookup and preset the instrument controls:*
 - a. *Hook up the frequency counter:* Connect **10 MHz REF OUTPUT** of the analyzer through a 50 Ω precision coaxial cable and a 50 Ω precision terminator to INPUT-A of the counter. See Figure 4-14.
 - b. *Set the counter controls:*

```

Function ..... A-FREQ
Gate time ..... 2 s

```
2. *Check the frequency:* Check that the frequency of the counter shows 10 MHz \pm 0.1 Hz.
3. *Disconnect the hookup:* Disconnect the cable at **10 MHz REF OUTPUT**.

Center Frequency Setting Test

This procedure checks that the center frequency setting error is within the specified range for the analyzer.

Equipment Required	One frequency counter (Item 1) One signal generator (Item 2) One 50 Ω BNC coaxial cable (Item 12) One 50 Ω N-N coaxial cable (Item 14)
Prerequisites	See page 4-12

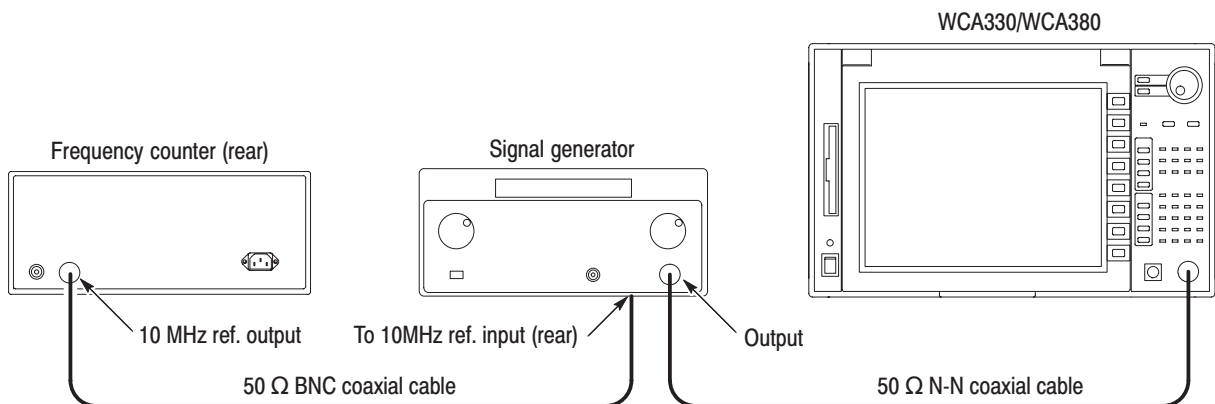


Figure 4-15: Initial test hookup

1. Install the test hookup and preset the instrument controls:

- a. *Hook up the frequency counter and the signal generator:* Connect the 10 MHz reference output of the counter through a 50 Ω BNC coaxial cable to the 10 MHz reference input of the signal generator. See Figure 4-15.
- b. *Set the signal generator controls:*
 - Frequency 5 MHz
 - Amplitude -10 dBm
 - RF Output On
- c. *Hook up the signal generator:* Connect the signal generator output through a 50 Ω N-N coaxial cable to the analyzer **RF INPUT**.

-
- d. *Set the analyzer controls:*
 - Press **SETUP:MAIN**.
 - Press the **Band** side key and select Baseband.
 - Press the **IF Mode** side key and select Normal.
 - Press the **Freq, Span, Ref...** side key and set the parameters as follows:
 - Freq 5 MHz
 - Span 100 Hz
 2. *Acquire data:* Press **START/STOP:ROLL**.
 3. *Check the frequency:*
 - a. Press **View:SRCH** to place the marker on the peak signal.
 - b. Read the frequency on the screen.
 - c. Check that the frequency is within a range of 5 MHz \pm 3.1 Hz.
 4. *Disconnect the hookup:* Disconnect the cable at **RF INPUT**.

Spectrum Purity Test

This procedure checks that the Carrier-to-Noise (C/No) is within the specified range for the analyzer.

Equipment Required	One signal generator (Item 3) One 50 Ω N-N coaxial cable (Item 14)
Prerequisites	See page 4-12

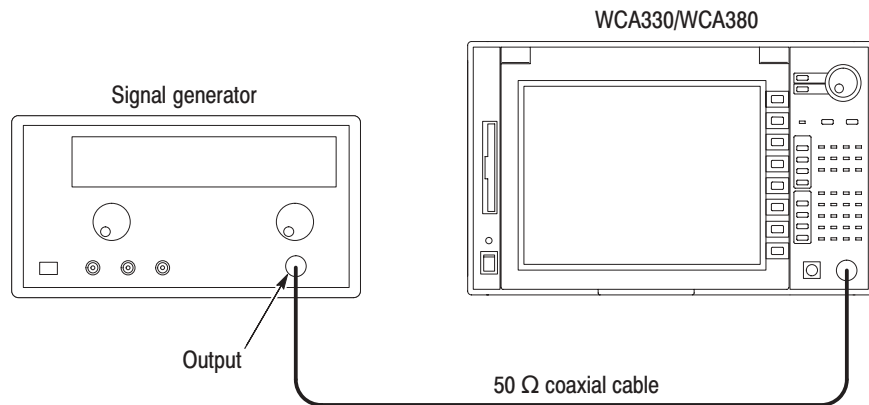


Figure 4-16: Initial test hookup

1. Install the test hookup and preset the instrument controls:

a. Set the analyzer controls:

- Press **CONFIG:MODE** → **Spectrum**.
- Press **SETUP:MAIN**.
- Press the **Band** side key and select RF (WCA330) or RF1 (WCA380).
- Press the **IF Mode** side key and select Normal.
- Press the **Memory Mode, Input, FFT...** side key and set the parameters as follows:

FFT Points 1024
 FFT Window Blackman

- Press [**Setup**] <- (top side key) → **Freq, Span, Ref...** and set the parameters as follows:
 - Freq 1500 MHz
 - Span 50 kHz
 - Ref -5 dBm
 - RF Att 0 dB
 - Press VIEW:**A** → **Average...** and set the parameters as follows:
 - Average On
 - Average Type RMS Expo
 - Num Averages 100
 - Press VIEW:**MKR** → **Measurement** and select C/No.
- b.** *Set the signal generator controls:*
- Frequency 1500 MHz
 - Amplitude -7 dBm
 - RF Output On
- c.** *Hook up the signal generator:* Connect the generator output through a 50 Ω N-N coaxial cable to the analyzer **RF INPUT**. See Figure 4-16.
- 2.** *Acquire data:* Press START/STOP:**ROLL**.
- 3.** *Wait:* Wait until the averaged waveform is stable.
- 4.** *Check C/No:*
- a.** Press VIEW:**SRCH** to place the marker on the peak signal.
 - b.** Press VIEW:**MKR** → **Band Power Markers...** and set the parameters as follows:
 - Center (Marker frequency) + 10 kHz
 - Width 1 kHz
 - c.** Confirm that C/No is 100 dBc/Hz or higher.

5. *Modify the analyzer settings:* Press **SETUP:SPAN** and set the span to 500 kHz.
6. *Wait:* Wait until the averaged waveform is stable.
7. *Check C/No:*
 - a. Press **VIEW:MKR** → **Band Power Markers...** and set the parameters as follows:
Center (Marker frequency) + 100 kHz
Width 10 kHz
 - b. Confirm that C/No is 103 dBc/Hz or higher.
8. *Modify the analyzer settings:* Press **SETUP:SPAN** and set the span to 5 MHz.
9. *Wait:* Wait until the averaged waveform is stable.
10. *Check C/No:*
 - a. Press **VIEW:MKR** → **Band Power Markers...** and set the parameters as follows:
Center (Marker frequency) + 1 MHz
Width 100 kHz
 - b. Confirm that C/No is 120 dBc/Hz or higher.
11. *Modify the analyzer settings:*
 - a. Press **SETUP:MAIN** → **IF Mode** and select HiRes.
 - b. Press **SETUP:SPAN** and set the span to 50 kHz.
12. *Wait:* Wait until the averaged waveform is stable.
13. *Check C/No:*
 - a. Press **VIEW:MKR** → **Band Power Markers...** and set the parameters as follows:
Center (Marker frequency) + 10 kHz
Width 1 kHz
 - b. Confirm that C/No is 95 dBc/Hz or higher.

-
14. *Modify the analyzer settings:* Press **SETUP:SPAN** and set the span to 500 kHz.
 15. *Wait:* Wait until the averaged waveform is stable.
 16. *Check C/No:*
 - a. Press **VIEW:MKR** → **Band Power Markers...** and set the parameters as follows:
 - Center (Marker frequency) + 100 kHz
 - Width 10 kHz
 - b. Confirm that C/No is 105 dBc/Hz or higher.
 17. *Modify the analyzer settings:* Press **SETUP:SPAN** and set the span to 5 MHz.
 18. *Wait:* Wait until the averaged waveform is stable.
 19. *Check C/No:*
 - a. Press **VIEW:MKR** → **Band Power Markers...** and set the parameters as follows:
 - Center (Marker frequency) + 1 MHz
 - Width 100 kHz
 - b. Confirm that C/No is 125 dBc/Hz or higher.
 20. *Disconnect the hookup:* Disconnect the cable at **RF INPUT**.

Reference Level Accuracy Test

This procedure checks the reference level error is within the specified range for the analyzer. It uses the power meter, power sensor, and step attenuator to set the signal generator output (i.e. the analyzer input) accurately.

Equipment Required	One signal generator (Item 2) One microwave signal generator (Item 5) One power meter (Item 7) Two power sensors (Item 8 and 9) One step attenuator (Item 10) Two 50 Ω N-N coaxial cables (Item 14)
Prerequisites	See page 4-12

1. Set up the power meter and sensor:

NOTE. Load the power sensor correction factors into the power meter, if not yet.

- a. Connect the power meter and the power sensor (Item 9 initially). See Figure 4-17 below.

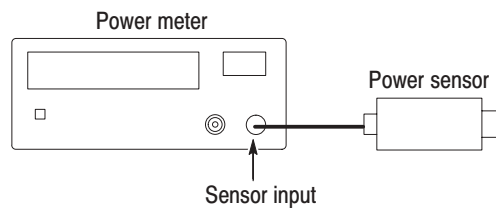


Figure 4-17: Initial hookup for setting up the power meter and sensor

- b. Warm up the power meter and sensor for more than 20 minutes.
- c. Press **ZERO** on the power meter.
- d. Connect the RF input of the power sensor to the power reference output of the power meter. See Figure 4-18 on the next page.
- e. Turn on **POWER REF** and execute the calibration.
- f. Disconnect the RF input of the power sensor from the reference output of the power meter.

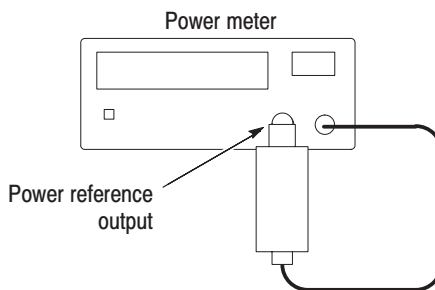


Figure 4-18: Hookup for calibrating the power sensor

2. Preset the instrument controls:

a. Set the WCA330/WCA380 controls:

- Press **CONFIG:MODE** → **Spectrum**.
- Press **SETUP:MAIN**.
- Press the **Band** side key and select Baseband.
- Press the **IF Mode** side key and select Normal.
- Press **Memory Mode, Input, FFT...** and set the parameters as follows:
 - FFT Points 1024
 - FFT Window Blackman
- Press **[Setup] <- (top side key) → Freq, Span, Ref...** and set the parameters as follows:
 - Freq 5 MHz
 - Span 5 MHz
 - Ref 30 dBm
- Press **VIEW:A → Average...** and set the parameters as follows:
 - Average On
 - Average Type RMS Expo
 - Num Averages 100

b. Perform the WCA330/WCA380 self calibration:
Press **CONFIG:UTILITY** → **Util A** → **Gain Cal**.

c. Set the signal generator controls:

Frequency 5 MHz
RF output On

3. Set the signal generator output:

a. Hook up the instruments: See Figure 4–19.

- Connect the signal generator (Item 2) output through a 50 Ω N-N coaxial cable to the step attenuator input.
- Connect the step attenuator output through a 50 Ω N-N coaxial cable to the power sensor input.

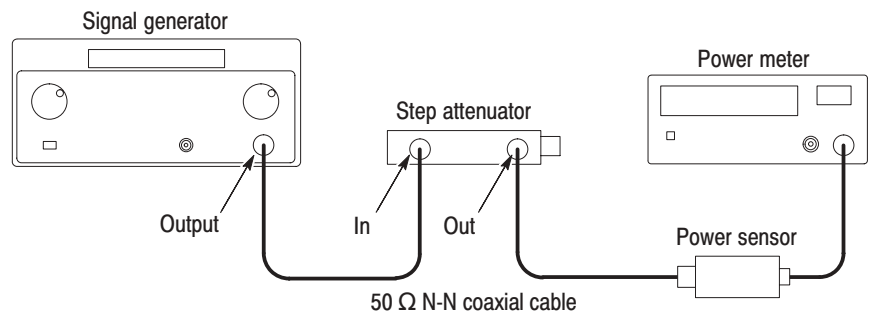


Figure 4-19: Hookup for setting the signal generator

- b. Set the step attenuator to 0 dBm.
- c. Adjust the signal generator so that the power meter reads 10 dBm.
- d. Disconnect the cable from the power sensor input.

4. Hookup the signal source: Connect the step attenuator output through a 50 Ω N-N coaxial cable to the WCA330/WCA380 **RF INPUT**. See Figure 4–20.

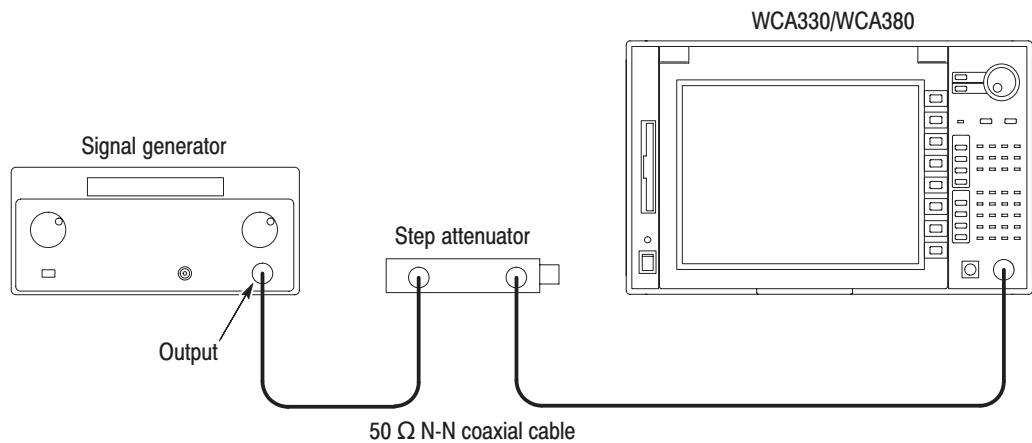


Figure 4-20: Hookup for checking the reference level accuracy

5. Check the WCA330/WCA380 reference level in the baseband: Do the procedure for each combination of the settings specified in Table 4–14.

Table 4–14: The instrument settings in the baseband

Analyzer ref. level setting	Step attenuator setting	Analyzer input level
+30 dBm	0 dB	+10 dBm
+20 dBm	0 dB	+10 dBm
+10 dBm	–10 dB	0 dBm
0 dBm	–20 dB	–10 dBm
–10 dBm	–30 dB	–20 dBm
–20 dBm	–40 dB	–30 dBm
–30 dBm	–50 dB	–40 dBm

- a. Set the reference level and step attenuator to one of the settings listed in Table 4–14 not yet checked. (Start with the 0 dB step attenuator setting.)
 - b. Press START/STOP:**ROLL** to acquire data.
 - c. Wait until the averaged waveform is stable.
 - d. Press START/STOP:**ROLL** again to stop the acquisition.
 - e. Press VIEW:**SRCH** to place the marker on the peak signal.
 - f. Read the peak level and confirm that the value is within ± 0.8 dBm of the input level.
 - g. Repeat substeps a through f until all reference level settings listed in Table 4–14 are checked.
6. Change the power sensor from Item 9 to Item 8 for the RF band:

NOTE. Load the power sensor correction factors into the power meter, if not yet.

- a. Disconnect the power sensor (Item 9) from the power meter.
- b. Connect the power sensor (Item 8) to the power meter. See Figure 4–17 on page 4–42.
- c. Specify the power sensor on the power meter.
- d. Do Step 1 on page 4–42 to calibrate the power meter and sensor.

7. *Modify the signal generator output:*

a. *Hook up the instruments:* See Figure 4–21.

- Connect the microwave signal generator (Item 5) output through a 50 Ω N-N coaxial cable to the step attenuator input.
- Connect the step attenuator output through a 50 Ω N-N coaxial cable to the power sensor input.

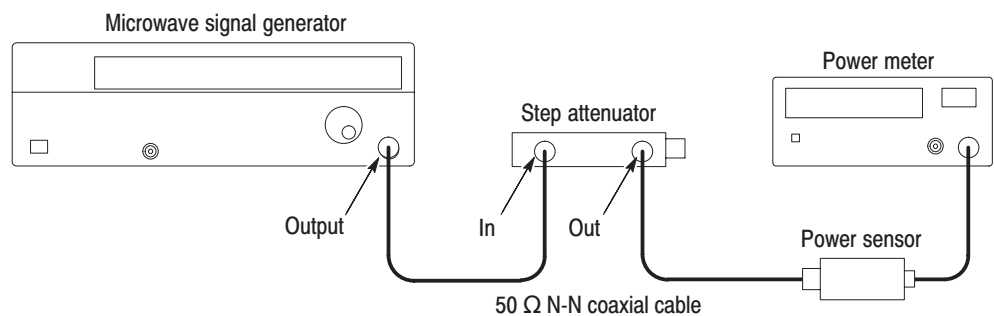


Figure 4-21: Hookup for setting the microwave signal generator

- b. Set the step attenuator to 0 dBm.
- c. Adjust the signal generator so that the power meter reads 10 dBm.
- d. Disconnect the cable from the power sensor input.

8. *Hookup the signal source:* Connect the step attenuator output through a 50 Ω N-N coaxial cable to the WCA330/WCA380 **RF INPUT**. See Figure 4–22.

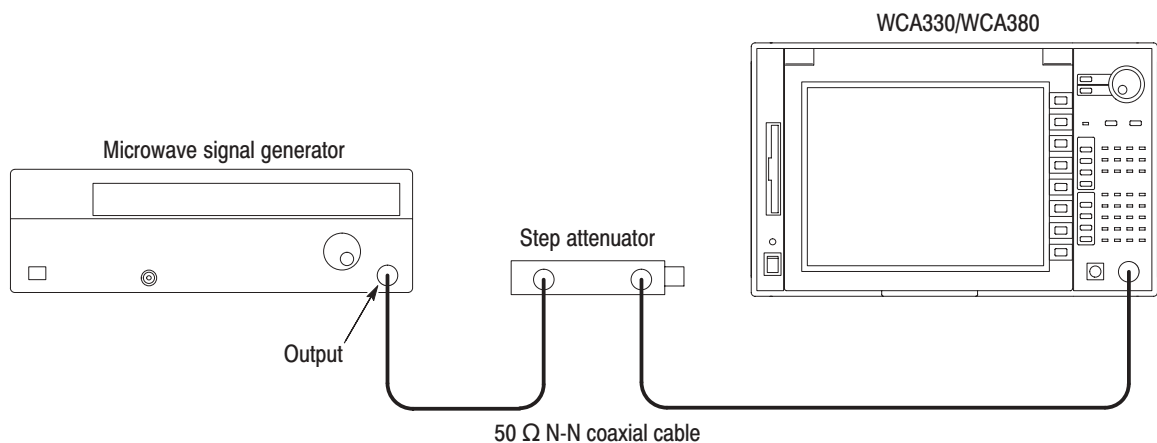


Figure 4-22: Hookup for checking the reference level accuracy

9. *Modify the instrument settings:*

- a. *Set the analyzer settings:* Press **SETUP:Freq** and set the parameters as follows.

Freq 1500 MHz
 Span 5 MHz
 Ref 30 dBm

- b. *Set the signal generator controls:*

Frequency 1500 MHz
 RF output On

10. *Check the WCA330/WCA380 reference level in the RF/RF1 band:* Do the procedure for each combination of the settings specified in Table 4–15.

Table 4–15: The instrument settings in the RF band

Analyzer ref. level setting	Step attenuator setting	Analyzer input level
+30 dBm	0 dB	+10 dBm
+20 dBm	0 dB	+10 dBm
+10 dBm	–10 dB	0 dBm
0 dBm	–20 dB	–10 dBm
–10 dBm	–30 dB	–20 dBm
–20 dBm	–40 dB	–30 dBm
–30 dBm	–50 dB	–40 dBm
–40 dBm	–60 dB	–50 dBm
–50 dBm	–70 dB	–60 dBm

- a. Set the reference level and step attenuator to one of the settings listed in Table 4–15 not yet checked. (Start with the 0 dB step attenuator setting.)
- b. Press **START/STOP:ROLL** to acquire data.
- c. Wait until the averaged waveform is stable.
- d. Press **START/STOP:ROLL** again to stop the acquisition.
- e. Press **VIEW:SRCH** to place the marker on the peak signal.
- f. Read the peak level and confirm that the value is within ± 1.5 dBm of the input level.
- g. Repeat substeps a through f until all reference level settings listed in Table 4–15 are checked.

NOTE. *The following steps are for WCA380 only. For WCA330, skip to Step 23.*

11. *Set the signal generator output:*

- a.** *Hook up the instruments:* Connect the step attenuator output through a 50 Ω N-N coaxial cable to the power sensor (Item 8) input. See Figure 4–21 on page 4–46.
- b.** Set the step attenuator to 0 dBm.
- c.** Adjust the signal generator so that the power meter reads 10 dBm.
- d.** Turn off the RF output of the signal generator.
- e.** Disconnect the cable from the power sensor input.

12. *Hookup the signal source:* Connect the step attenuator output through a 50 Ω N-N coaxial cable to the WCA330/WCA380 **RF INPUT**. See Figure 4–22.

13. *Modify the instrument settings:*

- a.** *Set the analyzer settings:* Press **SETUP:FREQ** and set the parameters as follows.

Freq 3000 MHz
 Span 5 MHz
 Ref 30 dBm

- b.** *Set the signal generator controls:*

Frequency 3000 MHz
 RF output On

14. *Check the WCA380 reference level in the RF2 band:* Do the procedure for each combination of the settings specified in Table 4–15 on page 4–47.

- a.** Set the reference level and step attenuator to one of the settings listed in Table 4–15 not yet checked. (Start with the 0 dB step attenuator setting.)
- b.** Press **START/STOP:ROLL** to acquire data.
- c.** Wait until the averaged waveform is stable.
- d.** Press **START/STOP:ROLL** again to stop the acquisition.
- e.** Press **VIEW:SRCH** to place the marker on the peak signal.
- f.** Read the peak level and confirm that the value is within ± 1.5 dBm of the input level.
- g.** Repeat substeps **a** through **f** until all reference level settings listed in Table 4–15 are checked.

15. *Set the signal generator output:*
- Hook up the instruments:* Connect the step attenuator output through a 50 Ω N-N coaxial cable to the power sensor (Item 8) input. See Figure 4–21 on page 4–46.
 - Set the step attenuator to 0 dBm.
 - Adjust the signal generator so that the power meter reads 10 dBm.
 - Turn off the RF output of the signal generator.
 - Disconnect the cable from the power sensor input.
16. *Hookup the signal source:* Connect the step attenuator output through a 50 Ω N-N coaxial cable to the WCA330/WCA380 **RF INPUT**. See Figure 4–22 on page 4–46.
17. *Modify the instrument settings:*
- Set the analyzer settings:* Press **SETUP:FREQ** and set the parameters as follows.

Freq	5000 MHz
Span	5 MHz
Ref	30 dBm
 - Set the signal generator controls:*

Frequency	5000 MHz
RF output	On
18. *Check the WCA380 reference level in the RF3 band:* Do the procedure for each combination of the settings specified in Table 4–15 on page 4–47.
- Set the reference level and step attenuator to one of the settings listed in Table 4–15 not yet checked. (Start with the 0 dB step attenuator setting.)
 - Press **START/STOP:ROLL** to acquire data.
 - Wait until the averaged waveform is stable.
 - Press **START/STOP:ROLL** again to stop the acquisition.
 - Press **VIEW:SRCH** to place the marker on the peak signal.
 - Read the peak level and confirm that the value is within ± 2.0 dBm of the input level.
 - Repeat substeps **a** through **f** until all reference level settings listed in Table 4–15 are checked.

19. Set the signal generator output:

- a. *Hook up the instruments:* Connect the step attenuator output through a 50 Ω N-N coaxial cable to the power sensor (Item 8) input. See Figure 4–21 on page 4–46.
- b. Set the step attenuator to 0 dBm.
- c. Adjust the signal generator so that the power meter reads 10 dBm.
- d. Turn off the RF output of the signal generator.
- e. Disconnect the cable from the power sensor input.

20. Hookup the signal source: Connect the step attenuator output through a 50 Ω N-N coaxial cable to the WCA330/WCA380 **RF INPUT**. See Figure 4–22 on page 4–46.

21. Modify the instrument settings:

- a. *Set the analyzer settings:* Press **SETUP:FREQ** and set the parameters as follows.

Freq 6500 MHz
 Span 5 MHz
 Ref 30 dBm

- b. *Set the signal generator controls:*

Frequency 6500 MHz
 RF output On

22. Check the WCA380 reference level in the RF4 band: Do the procedure for each combination of the settings specified in Table 4–15 on page 4–47.

- a. Set the reference level and step attenuator to one of the settings listed in Table 4–15 not yet checked. (Start with the 0 dB step attenuator setting.)
- b. Press **START/STOP:ROLL** to acquire data.
- c. Wait until the averaged waveform is stable.
- d. Press **START/STOP:ROLL** again to stop the acquisition.
- e. Press **VIEW:SRCH** to place the marker on the peak signal.
- f. Read the peak level and confirm that the value is within ±2.0 dBm of the input level.
- g. Repeat substeps **a** through **f** until all reference level settings listed in Table 4–15 are checked.

23. Disconnect the hookup: Disconnect the cable at **RF INPUT**.

Digital Demodulation Accuracy Test

This procedure checks the digital demodulation error is within the specified range for the analyzer.

Equipment Required	One signal generator (Item 4) One 50 Ω N-N coaxial cable (Item 14)
Prerequisites	See page 4-12

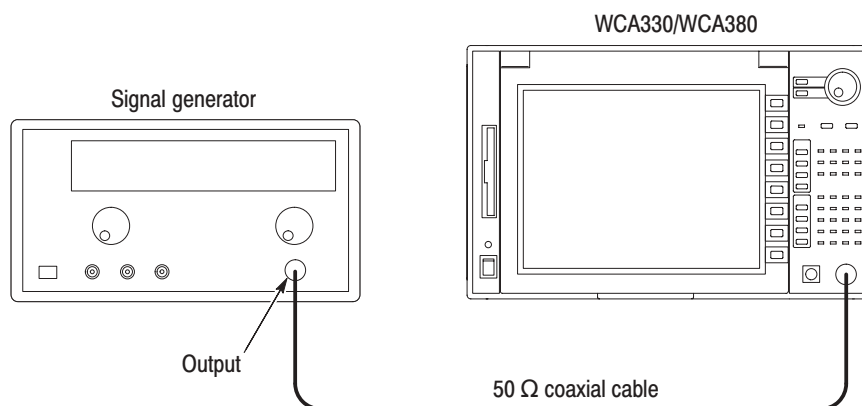


Figure 4-23: Initial test hookup

1. *Install the test hookup and preset the instrument controls:*
 - a. *Set the analyzer controls:*
 - Press **CONFIG:MODE** → **More...** (twice) → **Digital Demod.**
 - Press **SETUP:MAIN**.
 - Press the **Band** side key and select RF (WCA330) or RF1 (WCA380).
 - Press the **IF Mode** side key and select Wide.
 - Press **Freq, Span, Ref...** and set the parameters as follows:
 - Freq 2000 MHz
 - Span 20 MHz
 - Press **CONFIG:VIEW** → **View B** and select EVM.

- Press VIEW:C → **Manual Setup...**, and set the parameters as follows:

Modulation QPSK
 Symbol Rate 4.096M
 Measurement Filter Root Raised Cosine
 Reference Filter Raised Cosine
 Alpha/BT 0.2

- b. *Set the signal generator controls:*

Frequency 2 GHz
 Level -10 dBm

Digital modulation

State On
 Symbol rate 4,096,000 sym/s
 Filter type SQR cos
 Filter parameter 0.2
 Filter mode Low EVM

- c. *Hook up the signal generator:* Connect the generator output through a 50 Ω N-N coaxial cable to the analyzer **RF INPUT**. See Figure 4–23.

2. *Acquire data:* Press START/STOP:**BLOCK**.
3. *Check EVM:* Confirm that EVM is less than 2.5 % in View B.
4. *Disconnect the hookup:* Disconnect the cable at **RF INPUT**.

Test Record

Photocopy the following test record pages and use them to record the performance test results for your analyzer.

Report the following test data:

- *10 MHz reference output test* on page 4–35
- *Center frequency setting test* on page 4–36
- *Spectrum purity test* on page 4–38
- *Reference level accuracy test* on page 4–42
- *3rd order intermodulation distortion test*: This test is done in Test E on page 4–30. For obtaining the test results, refer to *Retrieving the Test Results* on page 4–18. The test title is “2-Tone Distortion” in the file *PV2.log*.
- *Digital demodulation accuracy test* on page 4–51
- *Frequency event trigger test*: This test is done in the *Internal trigger test* of the Baseband tests on page 4–19. The Pass/Fail result is shown in View C.

WCA330/WCA380 Test Record

Serial Number:

Certificate Number:

Calibration Date:

Technician:

10 MHz reference output test	Low limit	Test result	High limit
Initial accuracy	9,999,999 Hz		10,000,001 Hz

Center frequency setting test	Low limit	Test result	High limit
Frequency accuracy at 5 MHz (Span = 100 Hz)	4.9999969 MHz		5.0000031 MHz

Spectrum purity test				
IF mode	Offset	Low limit	Test result	High limit
Normal (at 1,500 MHz)	10 kHz			-100 dBc/Hz
	100 kHz			-103 dBc/Hz
	1 MHz			-120 dBc/Hz
HiRes (at 1,500 MHz)	10 kHz			-95 dBc/Hz
	100 kHz			-105 dBc/Hz
	1 MHz			-125 dBc/Hz

Reference level test				
Reference level	Test level	Low limit	Test result	High limit
Baseband (Center frequency = 5 MHz, Span = 5 MHz)				
+30 dBm	+10 dBm	+9.2 dBm		+10.8 dBm
+20 dBm	+10 dBm	+9.2 dBm		+10.8 dBm
+10 dBm	0 dBm	-0.8 dBm		+0.8 dBm
0 dBm	-10 dBm	-10.8 dBm		-9.2 dBm
-10 dBm	-20 dBm	-20.8 dBm		-19.2 dBm
-20 dBm	-30 dBm	-30.8 dBm		-29.2 dBm
-30 dBm	-40 dBm	-40.8 dBm		-39.2 dBm

Reference level test				
Reference level	Test level	Low limit	Test result	High limit
RF (WCA330) / RF1 (WCA380) (Center frequency = 1500 MHz, Span = 5 MHz, Normal IF mode)				
+30 dBm	+10 dBm	+8.5 dBm		+11.5 dBm
+20 dBm	+10 dBm	+8.5 dBm		+11.5 dBm
+10 dBm	0 dBm	-1.5 dBm		+1.5 dBm
0 dBm	-10 dBm	-11.5 dBm		-8.5 dBm
-10 dBm	-20 dBm	-21.5 dBm		-18.5 dBm
-20 dBm	-30 dBm	-31.5 dBm		-28.5 dBm
-30 dBm	-40 dBm	-41.5 dBm		-38.5 dBm
-40 dBm	-50 dBm	-51.5 dBm		-48.5 dBm
-50 dBm	-60 dBm	-61.5 dBm		-58.5 dBm
RF2 (WCA380 only) (Center frequency = 3000 MHz, Span = 5 MHz, Normal IF mode)				
+30 dBm	+10 dBm	+8.5 dBm		+11.5 dBm
+20 dBm	+10 dBm	+8.5 dBm		+11.5 dBm
+10 dBm	0 dBm	-1.5 dBm		+1.5 dBm
0 dBm	-10 dBm	-11.5 dBm		-8.5 dBm
-10 dBm	-20 dBm	-21.5 dBm		-18.5 dBm
-20 dBm	-30 dBm	-31.5 dBm		-28.5 dBm
-30 dBm	-40 dBm	-41.5 dBm		-38.5 dBm
-40 dBm	-50 dBm	-51.5 dBm		-48.5 dBm
-50 dBm	-60 dBm	-61.5 dBm		-58.5 dBm
RF3 (WCA380 only) (Center frequency = 5000 MHz, Span = 5 MHz, Normal IF mode)				
+30 dBm	+10 dBm	+8.0 dBm		+12.0 dBm
+20 dBm	+10 dBm	+8.0 dBm		+12.0 dBm
+10 dBm	0 dBm	-2.0 dBm		+2.0 dBm
0 dBm	-10 dBm	-12.0 dBm		-8.0 dBm
-10 dBm	-20 dBm	-22.0 dBm		-18.0 dBm
-20 dBm	-30 dBm	-32.0 dBm		-28.0 dBm
-30 dBm	-40 dBm	-42.0 dBm		-38.0 dBm
-40 dBm	-50 dBm	-52.0 dBm		-48.0 dBm
-50 dBm	-60 dBm	-62.0 dBm		-58.0 dBm

Reference level test				
Reference level	Test level	Low limit	Test result	High limit
RF4 (WCA380 only) (Center frequency = 6500 MHz, Span = 5 MHz, Normal IF mode)				
+30 dBm	+10 dBm	+8.0 dBm		+12.0 dBm
+20 dBm	+10 dBm	+8.0 dBm		+12.0 dBm
+10 dBm	0 dBm	-2.0 dBm		+2.0 dBm
0 dBm	-10 dBm	-12.0 dBm		-8.0 dBm
-10 dBm	-20 dBm	-22.0 dBm		-18.0 dBm
-20 dBm	-30 dBm	-32.0 dBm		-28.0 dBm
-30 dBm	-40 dBm	-42.0 dBm		-38.0 dBm
-40 dBm	-50 dBm	-52.0 dBm		-48.0 dBm
-50 dBm	-60 dBm	-62.0 dBm		-58.0 dBm

2-signal 3rd-distortion test		Low limit	Test result	High limit
3 rd order intermodulation distortion (Signal level ≤ -10 dBfs, 2 GHz)	HiRes IF mode			-73 dBc
	Normal IF mode			-70 dBc
	Wide IF mode			-55 dBc

Digital demodulation test	Low limit	Test result	High limit
EVM (QPSK, 4.096 Msps, 2 GHz carrier, 20 MHz span, Wide IF mode)			2.5 % rms

Frequency event trigger test	Normal	Abnormal
Mask resolution = 1 bin (Center frequency = 1500 MHz, Span = 5 MHz)		

Adjustment Procedures

Adjustment Procedures

This section contains information needed to manually adjust the WCA330 and WCA380 Wireless Communication Analyzers.

The section is divided into three subsections:

- General information about adjusting the analyzer
- A list of equipment required to perform the adjustments
- The written procedures for adjusting the analyzer

Purpose This procedure is used to return the analyzer to conformance with its *Warranted Characteristics* as listed in Section 1, *Specification*. It can also be used to optimize the performance of the analyzer. For performance verification procedures, refer to Section 4, *Performance Verification*.

Adjustment Interval Generally, these adjustments should be done every 12 months.

Adjustment After Repair After the removal and replacement of a module due to electrical failure, do the adjustment procedures in this section.

Adjustments Table 5-1 lists the adjustment procedures.

Table 5-1: Adjustments

Adjustments	Page
Adjustment of clock frequency	5-4
Adjustment of TFT panel luminance	5-6
Reconfiguration of down converter	5-8
Execution of auto calibration (CAL A to G)	5-24

NOTE. Whenever replacing the down converter, do the procedure Reconfiguration of Down Converter on page 5-8.

Requirements for Adjustments

Before doing the adjustments, note the following requirements.

Personnel This procedure is only to be performed by trained service technicians.

Warm-Up Period This analyzer requires a 20 minute warm-up time in a 20° C to 30° C environment before it is adjusted. Adjustments done before the operating temperature has stabilized may cause errors in performance.

Test Equipment Table 5–2 lists all test equipment required to adjust the analyzer.

Equipment Required

Table 5–2 lists the test equipment required to adjust the analyzer.

Table 5–2: Test equipment

Item description	Minimum requirements	Example	Purpose
1. Frequency counter	Frequency range: 10 MHz; Reference output: 10 MHz; Aging rate: $<5 \times 10^{-10}$ /day; Accuracy: <0.01 ppm at 10 MHz	Anritsu MF1603A option 03	Clock frequency adjustment
2. Signal generator	Frequency range: 10 kHz to 3 GHz; Output level: -70 dBm to +13 dBm; Accuracy: $<\pm 1$ dB; Function: FM	HP 8648C ¹	RF flatness compensation
3. Microwave signal generator	Frequency range: 10 MHz to 8 GHz; Output level: -4 dBm to +10 dBm; Accuracy: $<\pm 1$ dB	HP 83711B ¹ or Anritsu 69053A ¹	RF spurious correction
4. Waveform generator	Arbitrary waveform; Two output channels; Sampling frequency: 50 kHz to 1 GHz; Amplitude range: 20 mV to 2 V	Sony/Tektronix AWG520 ¹	Software-based adjustments
5. RF power meter ²	10 MHz to 8 GHz	HP 4418B ¹	RF flatness compensation
6. RF power sensor ²	10 MHz to 8 GHz; RF Flatness: <3 %; Uncertainty of calibration factor data: <2 % (RSS)	HP 4412A	RF flatness compensation

Table 5-2: Test equipment (Cont.)

Item description	Minimum requirements	Example	Purpose
7. BNC cable (two required)	50 Ω , 36 in, male to male BNC connectors	Tektronix part number 012-1341-00	Signal interconnection
8. N-N cable	50 Ω , 36 in, male to male N connectors		Signal interconnection
9. GPIB cable (two required)	2m, double-shielded	Tektronix part number 012-0991-00	Software-based adjustments
10. Terminator	Impedance: 50 Ω ; connectors: female BNC input, male BNC output	Tektronix part number 011-0049-01	Signal termination for clock frequency adjustment
11. N adapter ²	Female to female N connectors		Signal interconnection
12. BNC-N adapter	Female BNC to male N connectors	Standard accessory Tektronix part number 103-0045-00	Signal interconnection
13. Adjustment Tool			Manual adjustments
14. SG flatness floppy disk	Created or updated with the procedures described on page 5-15	3.5 inch, 720 K or 1.44 Mbyte, DOS-compatible floppy disk	Storing flatness correction data for the signal generator (Item 2)
15. MSG flatness floppy disk	Created or updated with the procedures described on page 5-15	3.5 inch, 720 K or 1.44 Mbyte, DOS-compatible floppy disk	Storing flatness correction data for the microwave signal generator (Item 3)
16. AWG520 setup disk (CD-ROM)	Contain the setting and waveform files for the analyzer calibration	Tektronix part number 062-A250-00	Setting up the AWG520 waveform generator

¹ Use this instrument only. The adjustment procedures specify that the analyzer controls this instrument over the GPIB.

² Required only when creating a flatness correction files for the signal generators (Item 2 and 3).

Adjustments

Clock Frequency Adjustment

This procedure adjusts the analyzer internal clock frequency.

Equipment Required	One frequency counter (Item 1) One 50 Ω BNC coaxial cable (Item 7) One 50 Ω terminator (Item 10) One adjustment tool (Item 13)
---------------------------	---

NOTE. Warm up the analyzer for more than 20 minutes and the frequency counter for more than 24 hours.

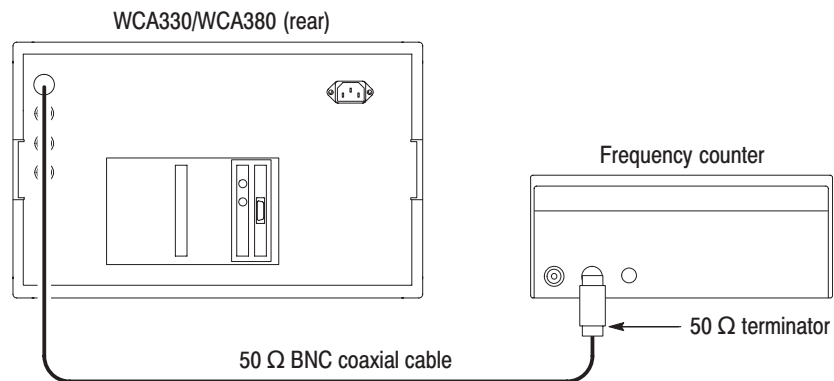


Figure 5-1: Initial test hookup

1. Access the inside of the analyzer: See *Removal and Installation Procedures* in Section 6 to remove the top cabinet.
2. Connect the test equipment and set test equipment controls:
 - a. Hook up the frequency counter: Connect **10 MHz REF OUTPUT** of the analyzer through a 50 Ω BNC coaxial cable and a 50 Ω terminator to INPUT-A of the counter. See Figure 5-1.
 - b. Set the frequency counter controls:

Function A-FREQ
 Gate time 2 s

3. *Adjust the clock frequency:* Adjust R100 on the A72 DC Power-3 board (see Figure 5-2) so that the counter frequency is $10 \text{ MHz} \pm 0.1 \text{ Hz}$.

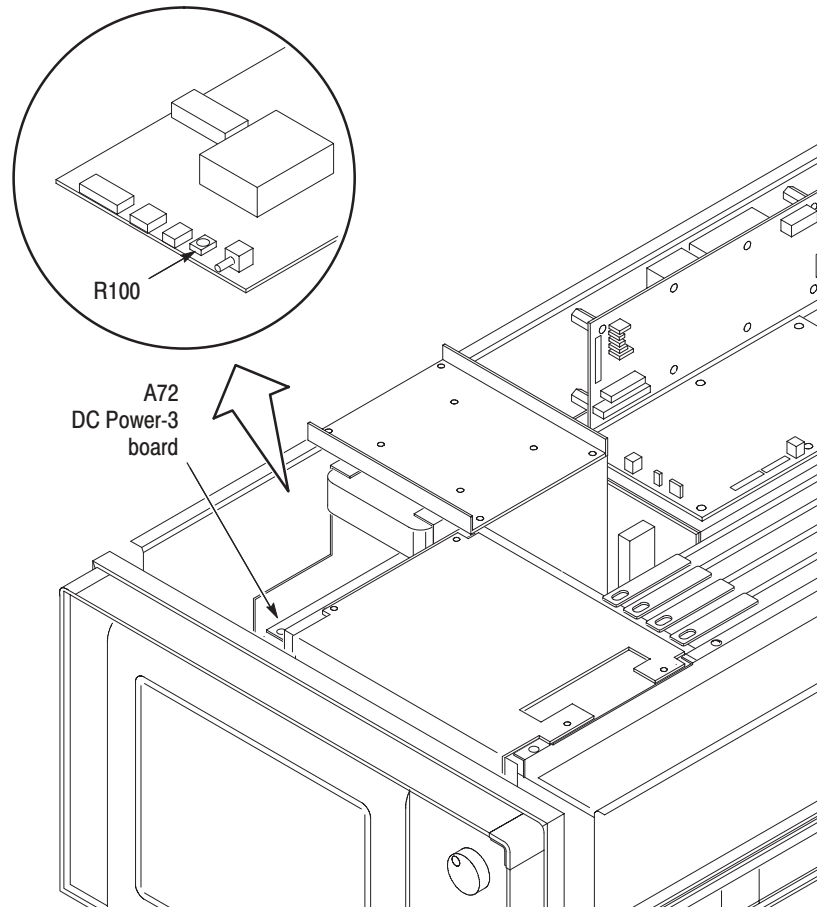


Figure 5-2: Adjustment location for the clock frequency

4. *Restore the analyzer to normal operation:*
 - a. Power off the analyzer.
 - b. Refer to *Removal and Installation Procedures* in Section 6 to reinstall the top cabinet and other modules removed in step 1.

TFT Panel Luminance Adjustment

This procedure adjusts the TFT panel luminance.

Equipment Required	One adjustment tool (Item 13)
---------------------------	-------------------------------

STOP. *This procedure is not part of the complete adjustment procedure. Only use this procedure to adjust the display assembly if it has been repaired or if brightness and contrast have become unsatisfactory.*

1. *Access the inside of the analyzer:* Remove the top cabinet. Refer to *Removal and Installation Procedures* in Section 6.
2. *Make the luminance adjustment:*
 - a. Locate R501 on the A71 DC power-2 board. See Figure 5–3.
 - b. Adjust R501 so that the luminance is satisfactory.
3. *Restore the analyzer to normal operation:*
 - a. Power off the analyzer.
 - b. Reinstall the top cabinet and other modules removed in step 1. Refer to *Removal and Installation Procedures* in Section 6.

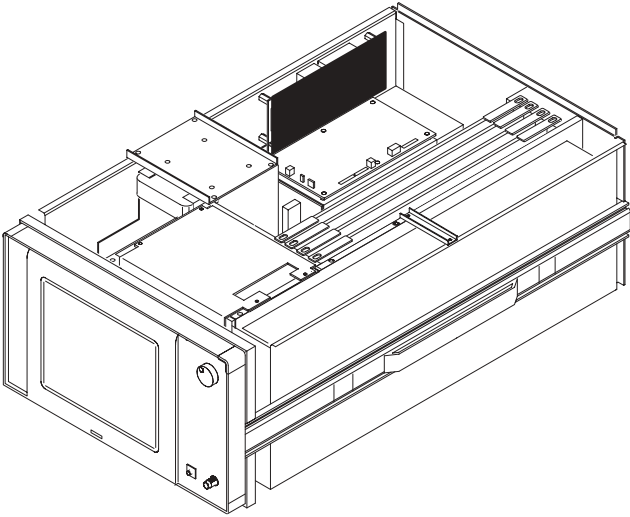
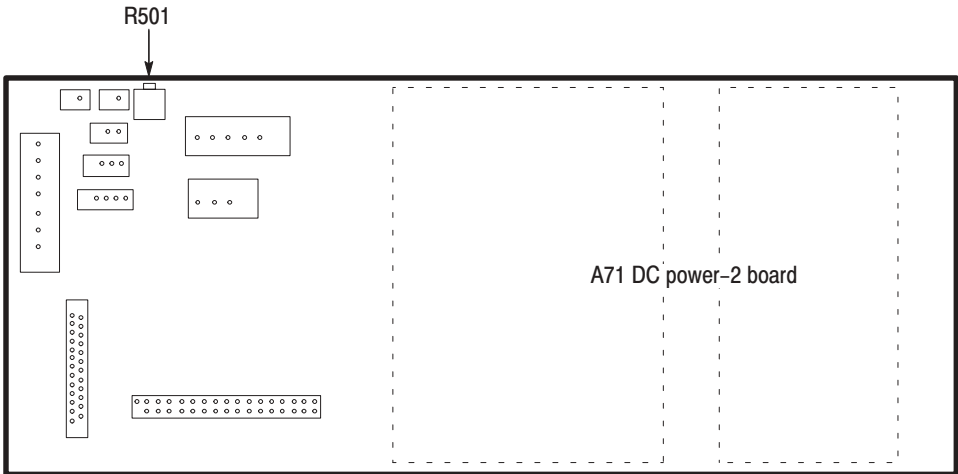


Figure 5-3: Adjustment location of TFT panel luminance

**Reconfiguration of
Down Converter**

The following procedures update the down-converter configuration file when replacing the down converter unit 1 and/or 2. The procedure for the down converter unit 2 is for the WCA380 analyzer only.

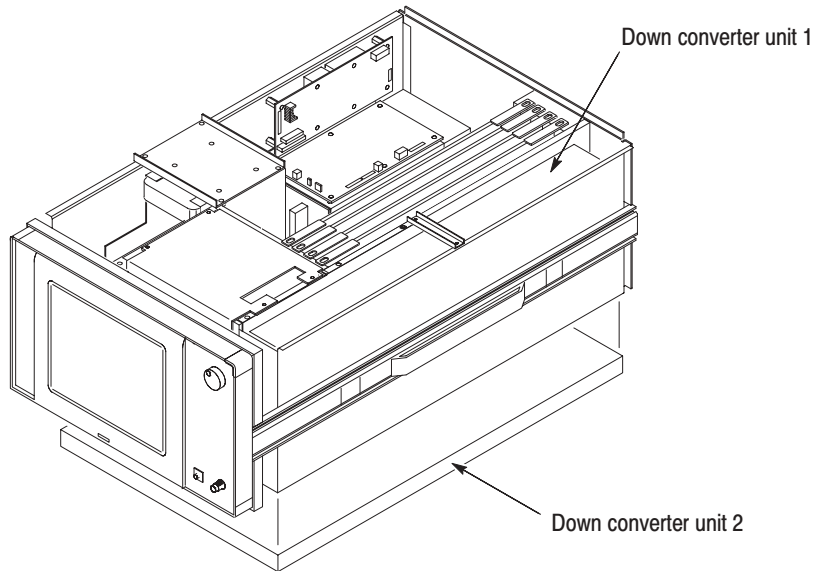


Figure 5-4: Location of the down converter unit 1 and 2

Reconfiguration of Down Converter Unit 1. When replacing the down converter unit 1, do the following procedure.

Equipment Required	One signal generator (Item 2) One 50 Ω N-N coaxial cable (Item 8)
---------------------------	---

1. Edit the RF DAC setting:

- a. Press **CONFIG:Mode** → **Load** → **Dir** and select the directory *Bin* using the general purpose knob.
- b. Press **Expand Dir** → **File** and select the file *cal.cfd* using the general purpose knob.
- c. Press **OK**.
- d. Note the “m” and “o” values which are indicated on the front surface of the down converter unit 1 on the right side of the analyzer.
- e. Press **VIEW:C** → **Dac...** → **YTO...** and replace the parameters as follows using the numeric keypad.

Conv DacGain	“m” value
Conv DacOffset	“o” value
- f. Press **Write Dac.txt**.

2. *Install the test hookup and preset the instrument controls:*

a. *Set the signal generator controls:*

Frequency 1500 MHz
 Amplitude -10 dBm
 RF Output On

b. *Hook up the signal generator:* Connect the generator output through a 50 Ω N-N coaxial cable to the analyzer **RF INPUT**. See Figure 5-5.

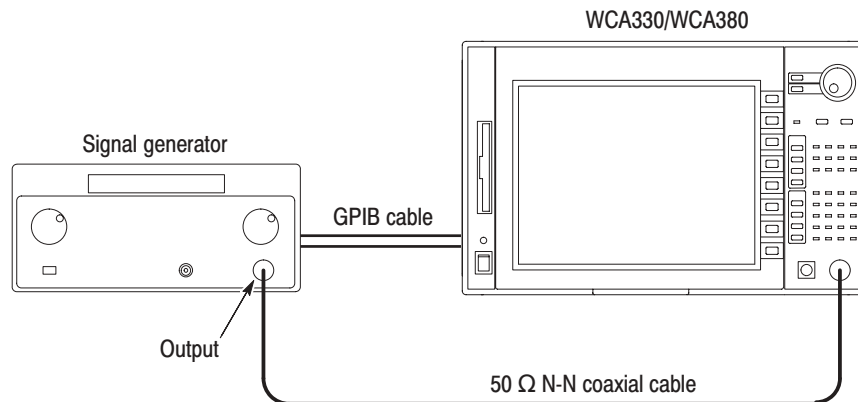


Figure 5-5: Test hookup

c. *Set the analyzer controls:*

- Press **CONFIG:Mode** → **Spectrum**.
- Press **SETUP:MAIN**.
- Press the **Band** side key and select RF (WCA330) or RF1 (WCA380).
- Press the **IF Mode** side key and select Normal.
- Press **SETUP:MAIN** → **Freq, Span, Ref...** and set the parameters as follows:

Frequency 1500 MHz
 Span 3 GHz

3. *Acquire data:* Press **START/STOP:ROLL**.

4. *Check the display:* Confirm that a spectrum displays at around 1500 MHz.

5. *Disconnect the hookup:* Disconnect the cable at **RF INPUT**.

Reconfiguration of Down Converter Unit 2. When replacing the down converter unit 2, do the following procedure. This procedure is for WCA380 only.

Equipment Required	One signal generator (Item 3) One 50 Ω N-N coaxial cable (Item 8)
---------------------------	---

1. *Edit the RF DAC setting:*
 - a. Press **CONFIG:Mode** → **Load** → **Dir** and select the directory *Bin* using the general purpose knob.
 - b. Press **Expand Dir** → **File** and select the file *cal.cfd* using the general purpose knob.
 - c. Press **OK**.
 - d. Note the “GAIN” and “OFFSET” values which are labeled on the surface of the YIG tuning filter (YTF) on the down converter unit 2 attached on the bottom of the analyzer (see Figure 5–6).

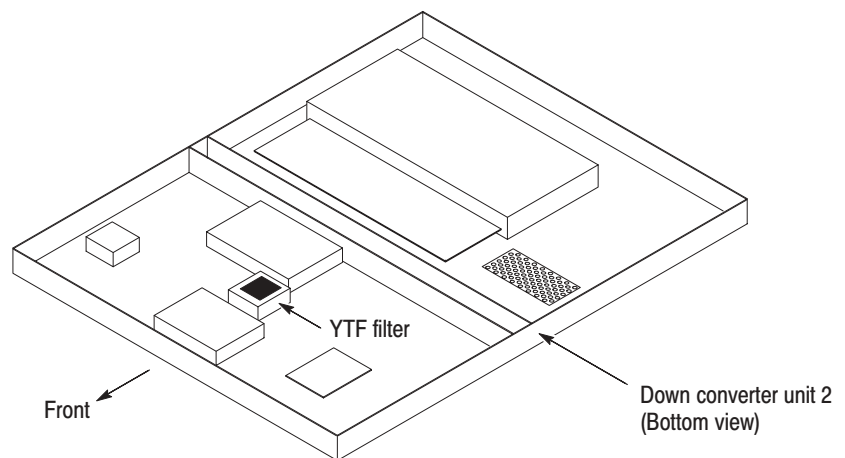


Figure 5-6: Location of labeling the “GAIN” and “OFFSET” values

- e. Press **VIEW:C** → **Dac...** → **YTF...** and replace the parameters as follows using the numeric keypad.

Conv YtfGain1	“GAIN” value
Conv YtfOffset1	“OFFSET” value
Conv YtfGain2	“GAIN” value
Conv YtfOffset2	“OFFSET” value
- f. Press **Write WcaDac.cal**.

2. *Install the test hookup and preset the instrument controls:*

a. *Set the signal generator controls:*

Frequency 6500 MHz
 Amplitude -10 dBm
 RF Output On

b. *Hook up the signal generator:* Connect the generator output through a 50 Ω N-N coaxial cable to the analyzer **RF INPUT**. See Figure 5-5.

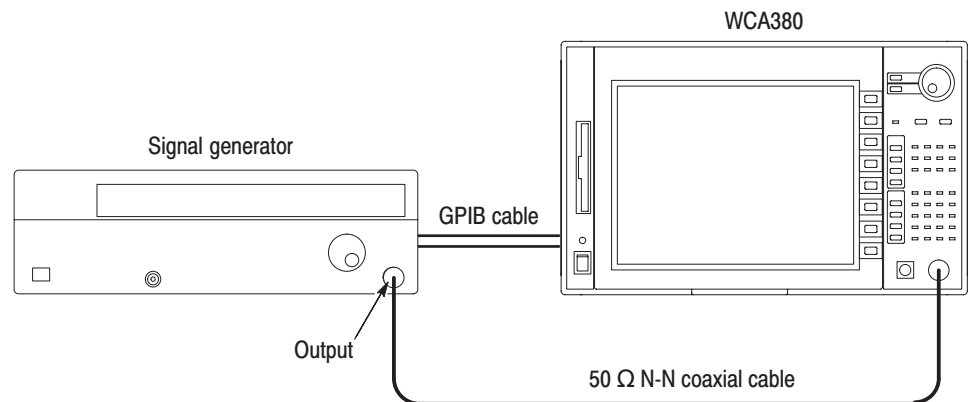


Figure 5-7: Test hookup

c. *Set the analyzer controls:*

- Press **CONFIG:Mode** → **Spectrum**.
- Press **SETUP:MAIN**.
- Press the **Band** side key and select RF4.
- Press the **IF Mode** side key and select Normal.
- Press **SETUP:MAIN** → **Freq, Span, Ref...** and set the parameters as follows:

Frequency 6500 MHz
 Span 3 GHz

3. *Acquire data:* Press **START/STOP:ROLL**.

4. *Check the display:* Confirm that a spectrum displays at around 6500 MHz.

5. *Disconnect the hookup:* Disconnect the cable at **RF INPUT**.

Auto Calibration Procedures

This section describes the procedures to run the internal calibration routines. The auto calibration is divided into five procedures, CAL A to G, due to the external signal connections. CAL G is for WCA380 only.

Table 5-3: Auto calibration

Procedure	Item	Purpose	Page
CAL A	DC offset	Minimize the baseband DC offset	5-24
	Center spurious	Minimize the baseband center spurious	
	Gain	Adjust the baseband gain for each range	
	RF gain	Adjust gain for each range in the RF (WCA330) / RF1 (WCA380) band	
	Reference level	Adjust the RF 25 MHz reference level	
	IF flatness	Correct the gain flatness within the IF bandwidth	
	RF flatness	Correct gain flatness for the RF (WCA330) / RF1 (WCA380) band	
	IQ offset	Minimize the wideband IQ offset	
CAL B	RF spurious	Minimize spurious for the RF (WCA330) / RF1 (WCA380) band	5-26
CAL C	IQ level balance	Balance I and Q levels	5-28
	IQ DC balance	Balance the wideband IQ gain and phase	5-28
	IQ AC balance	Balance the wideband IQ group delay	
CAL D	Wide gain	Adjust the wideband gain for each range	5-29
	Wide flatness	Correct the wideband gain flatness	
	IQ AC balance 2	Balance the wideband IQ group delay in detail	
	IQ shift	Correct the wideband IQ offset shift	
CAL E	IQ scale	Adjust the IQ input voltage scale	5-31
CAL F	Self gain-cal	Execute the self gain-calibration	5-33
	IF phase linearity	Correct the phase linearity within the IF bandwidth	
	Wide phase linearity	Correct the wideband phase linearity	
CAL G (WCA380 only)	RF2-4 RF gain	Adjust gain for each range for the RF2, RF3, and RF4 band	5-35
	RF3 IF flatness	Correct gain flatness within the IF bandwidth for the RF3 band	
	RF2-4 RF flatness	Correct gain flatness for the RF2, RF3, and RF4 band	
	RF2 spurious	Minimize spurious for the RF2 band	
	RF3 spurious	Minimize spurious for the RF3 band	
	RF4 spurious	Minimize spurious for the RF4 band	

NOTE. Do all the procedures in this order, to produce consistent results.

Preparation Do the following procedures before executing the auto calibration:

- Install the setup files on the AWG520 waveform generator.
- Prepare the flatness correction file for the signal generators.

Installing Setup Files on the Waveform Generator. The AWG520 waveform generator (Item 4) is used in the auto calibration (CAL E and F) and tests (Test D and F; refer to *Performance Verification*). The setting and waveform files must be installed from the AWG520 Setup Disk (CD-ROM, Item 16, Tektronix part number 062-A250-XX) onto the waveform generator hard disk before executing the auto calibration or tests.

- Copy all the files from the CD-ROM directory /3086 to the AWG520 directory /3086 using FTP.

For transferring the files from a PC to AWG520 using FTP, refer to *the AWG500 series User Manual*.

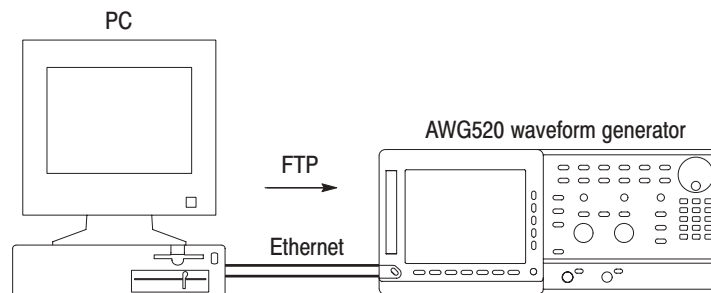


Figure 5-8: Downloading the setup files for AWG520

The following lists the setup files contained in the CD-ROM.

For adjustment

IQSCL12.SET	NPHCAL.SET	WPHCALB.WFM
IQSCL1.WFM	NPHCALB.WFM	
IQSCL2.WFM	WPHCAL.SET	

For performance verification

IQPV1.WFM	WQPRB2.WFM	FM5M8MS.WFM
IQPV2.WFM	AM5M50.WFM	SIN10P.WFM
WQPRB1.SET	DC.WFM	SIN100P.WFM
WQPRB1.WFM	FM5M1MS.WFM	SWP7M1.WFM
WQPRB2.SET	FM5M2MS.WFM	SWP7M2.WFM

Preparing the Flatness Correction File. The auto calibration CAL A and G need the SG and MSG flatness floppy disks (Item 14 and 15), respectively. The following procedures measure the flatness correction data for the signal generator (Item 2) and the microwave signal generator (Item 3) and saves the data to a floppy disk.

You must create or update the flatness correction file when one of these conditions is met:

- When you calibrate the analyzer initially
- When you calibrate the signal generator or microwave signal generator
- When you use another signal generator or microwave signal generator
- When you use another N-N cable
- When one year has elapsed from the last update of the file for the generator

The procedures are shown on the following pages:

- Preparing the SG flatness floppy disk (Item 14) page 5–16
- Preparing the MSG flatness floppy disk (Item 15) page 5–20

Preparing the SG flatness floppy disk (Item 14)

Equipment Required	One signal generator (Item 2) One power meter (Item 5) One power sensor (Item 6) One N-N cable (Item 8) Two GPIB cables (Item 9) One N adapter (Item 11) One floppy disk (Item 14)
---------------------------	--

1. Install the test hookup and preset the instrument controls:

NOTE. Load the power sensor correction factors into the power meter.

- a. Turn off the signal generator, power meter, and analyzer.
- b. Connect RF Output of the signal generator through an N adapter followed by an N-N coaxial cable to RF Input of the power sensor. See Figure 5-9.

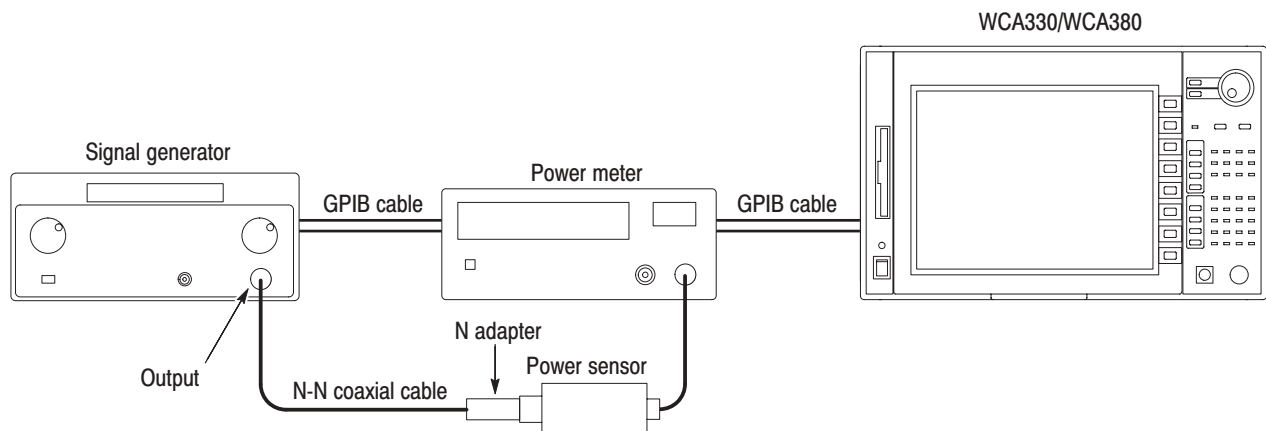


Figure 5-9: Initial test hookup

- c. Connect the GPIB cables at the signal generator, power meter, and analyzer rear panel.
 - d. Turn on the signal generator, power meter, and analyzer.
 - e. Set the GPIB address for the signal generator to 1, and the GPIB address for the power meter to 13.
2. *Let the instruments warm up:* Allow a 20 minute warm-up period before you go to the next step.
 3. *Perform the measurement:*
 - a. Press **CONFIG:Mode** → **Load** → **Dir** and select the directory *Bin* using the general purpose knob.
 - b. Press **Expand Dir** → **File** and select the file *cal.cfd* using the general purpose knob.
 - c. Press **OK**.
 - d. Press **View:C** → **SG...** → **SG Level**.
 - e. When the “Zero Cal” message box appears, do the following steps:
 - Connect the power sensor input to the power reference output of the power meter (see Figure 5–10).
 - Press **OK** in the message box.
 - If you want to quit the SG Level measurement, press **Cancel**.

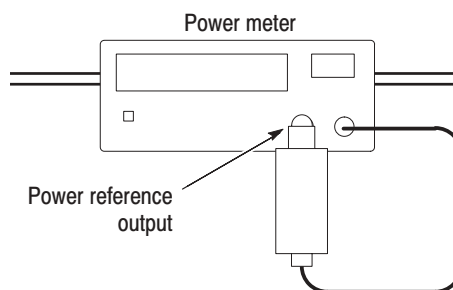


Figure 5–10: Hookup for calibrating the power sensor

- f. When the “Sensor Cal” message box appears, press **OK**.
If you want to quit the SG Level measurement, press **Cancel**.
- g. When the “Zero Cal” message box appears again, do the following steps:
 - Connect the signal generator output through an N adapter followed by an N-N coaxial cable to the power sensor input (see Figure 5–9 again).
 - Turn off the signal generator output.
 - Press **OK** in the message box.
 - If you want to quit the SG Level measurement, press **Cancel**.
- h. When the “Measurement” message box appears, do the following steps:
 - Turn on the signal generator output.
 - Press **OK** in the message box.
 - If you want to quit the SG Level measurement, press **Cancel**.
- i. Press **SG Flatness**.
- j. When the “Zero Cal” message box appears, do the following steps:
 - Connect the power sensor input to the power reference output of the power meter (see Figure 5–10 again).
 - Press **OK** in the message box.
 - If you want to quit the SG Flatness measurement, press **Cancel**.
- k. When the “Sensor Cal” message box appears, press **OK**.
If you want to quit the SG Flatness measurement, press **Cancel**.
- l. When the “Zero Cal” message box appears again, do the following steps:
 - Connect the signal generator output through an N adapter followed by an N-N coaxial cable to the power sensor input (see Figure 5–9 again).
 - Turn off the signal generator output.
 - Press **OK** in the message box.
 - If you want to quit the SG Flatness measurement, press **Cancel**.

- m. When the “Measurement” message box appears, do the following steps:
 - Turn on the signal generator output.
 - Press **OK** in the message box.
 - If you want to quit the SG Flatness measurement, press **Cancel**.
- 4. *Save the data on a floppy disk:*
 - a. Insert the adjustment floppy disk into the analyzer disk drive.
 - b. Press **Copy RF1 to Floppy** side key.

This copies the following two files under the directory
c:\Program Files\Sony Tektronix\wca\Sys to the floppy disk:

wcasglevel1.cal wcasgrfflatness1.cal

- 5. *Disconnect the hookup:*
 - a. Remove the floppy disk by pressing the eject button.
 - b. Turn off the signal generator, power meter, and analyzer.
 - c. Disconnect the GPIB cables.
 - d. Disconnect the power sensor and the N-N cable.

Preparing the MSG flatness floppy disk (Item 15)

Equipment Required	One microwave signal generator (Item 3) One power meter (Item 5) One power sensor (Item 6) One N-N cable (Item 8) Two GPIB cables (Item 9) One N adapter (Item 11) One floppy disk (Item 15)
---------------------------	--

1. Install the test hookup and preset the instrument controls:

NOTE. Load the power sensor correction factors into the power meter.

- a. Turn off the signal generator, power meter, and analyzer.
- b. Connect RF Output of the signal generator through an N adapter followed by an N-N coaxial cable to RF Input of the power sensor. See Figure 5-11.

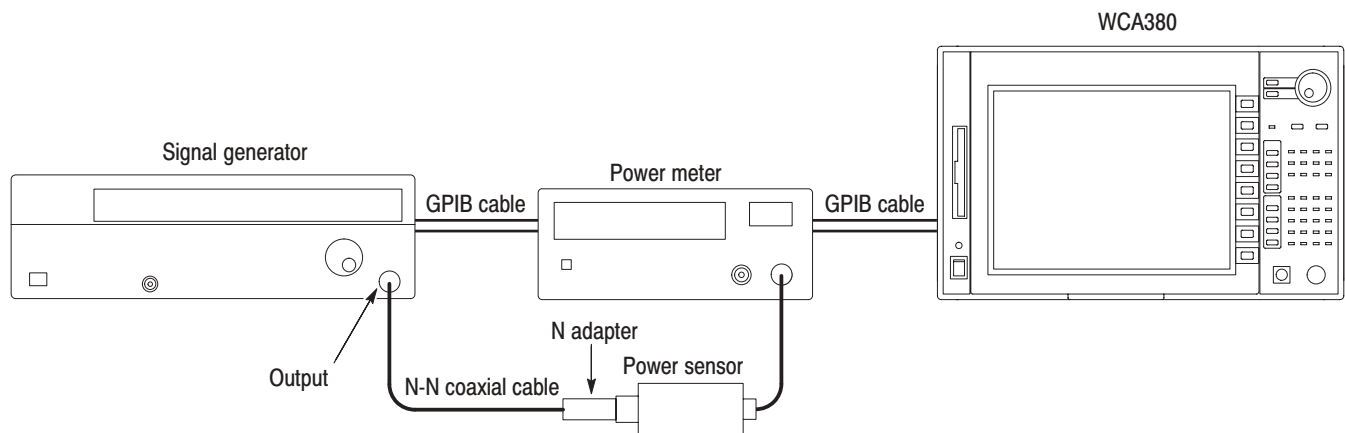


Figure 5-11: Test hookup

- c. Connect the GPIB cables to the signal generator, power meter, and analyzer rear panel.
 - d. Turn on the signal generator, power meter, and analyzer.
 - e. Set the GPIB address for the signal generator to 5, and the GPIB address for the power meter to 13.
2. *Let the instruments warm up:* Allow a 20 minute warm-up period before you go to the next step.
3. *Perform the measurement:*
- a. Press **CONFIG:Mode** → **Load** → **Dir** and select the directory *Bin* using the general purpose knob.
 - b. Press **Expand Dir** → **File** and select the file *cal.cfd* using the general purpose knob.
 - c. Press **OK**.
 - d. Press **View:C** → **SG...** → **More...** and select either HP or Anritus with the **RF2-4 SG** side key according to your instrument.
 - e. Press **RF2-4 SG Level**.
 - f. When the “Zero Cal” message box appears, do the following steps:
 - Connect the power sensor input to the power reference output of the power meter (see Figure 5-12).
 - Press **OK** in the message box.
 - If you want to quit the SG Level measurement, press **Cancel**.

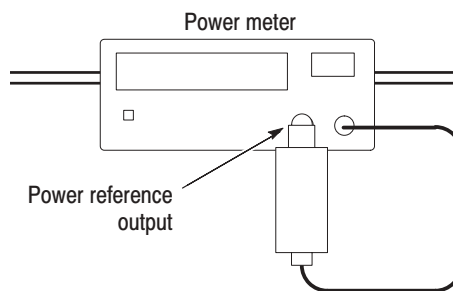


Figure 5-12: Hookup for calibrating the power sensor

- g.** When the “Sensor Cal” message box appears, press **OK**.
If you want to quit the SG Level measurement, press **Cancel**.
- h.** When the “Zero Cal” message box appears again, do the following steps:

 - Connect the signal generator output through an N adapter followed by an N-N coaxial cable to the power sensor input (see Figure 5–11 again).
 - Turn off the signal generator output.
 - Press **OK** in the message box.
 - If you want to quit the SG Level measurement, press **Cancel**.
- i.** When the “Measurement” message box appears, do the following steps:

 - Turn on the signal generator output.
 - Press **OK** in the message box.
 - If you want to quit the SG Level measurement, press **Cancel**.
- j.** Press **RF2–4 SG Flatness**.
- k.** When the “Zero Cal” message box appears, do the following steps:

 - Connect the power sensor input to the power reference output of the power meter (see Figure 5–12 again).
 - Press **OK** in the message box.
 - If you want to quit the SG Flatness measurement, press **Cancel**.
- l.** When the “Sensor Cal” message box appears, press **OK**.
If you want to quit the SG Flatness measurement, press **Cancel**.
- m.** When the “Zero Cal” message box appears again, do the following steps:

 - Connect the signal generator output through an N adapter followed by an N-N coaxial cable to the power sensor input (see Figure 5–11 again).
 - Turn off the signal generator output.
 - Press **OK** in the message box.
 - If you want to quit the SG Flatness measurement, press **Cancel**.

- n. When the “Measurement” message box appears, do the following steps:
 - Turn on the signal generator output.
 - Press **OK** in the message box.
 - If you want to quit the SG Flatness measurement, press **Cancel**.
4. *Save the data on a floppy disk:*
 - a. Insert the adjustment floppy disk into the analyzer disk drive.
 - b. Press **Copy RF2–4 to Floppy** side key.

This copies the following six files under the directory
c:\Program Files\Sony Tektronix\wca\Sys to the floppy disk:

wcasglevel2.cal	wcasgrfflatness2.cal
wcasglevel3.cal	wcasgrfflatness3.cal
wcasglevel4.cal	wcasgrfflatness4.cal

5. *Disconnect the hookup:*
 - a. Remove the floppy disk by pressing the eject button.
 - b. Turn off the signal generator, power meter, and analyzer.
 - c. Disconnect the GPIB cables.
 - d. Disconnect the power sensor and the N-N cable.

CAL A This procedure executes the auto calibration CAL A.

NOTE. In this procedure, you need a floppy disk storing the flatness correction file sflatoff.txt. Refer to Preparing the Flatness Correction File on page 5–15 for creating or updating the file.

Equipment Required	One signal generator (Item 2) One N-N cable (Item 8) One GPIB cable (Item 9) One SG flatness floppy disk (Item 14)
Prerequisites	Refer to page 5–13.

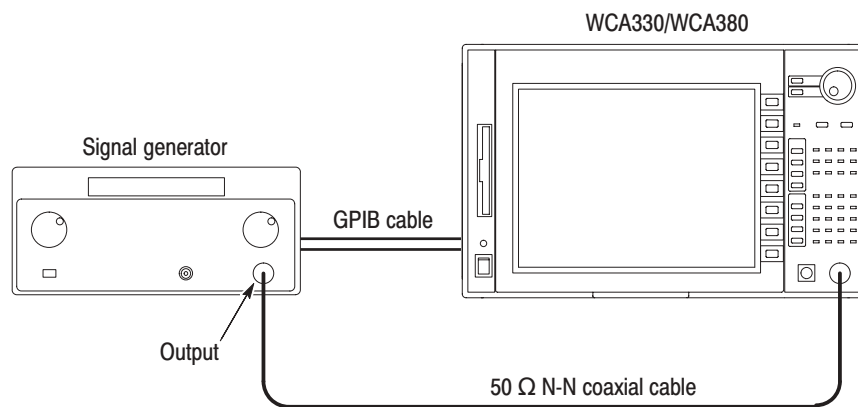


Figure 5–13: Initial test hookup

1. *Install the test hookup and preset the instrument controls:*
 - a. Power off the WCA330/WCA380 analyzer and the signal generator.
 - b. Connect the generator output through a 50 Ω N-N coaxial cable to the analyzer **RF INPUT**. See Figure 5–13.
 - c. Connect the analyzer and the generator with a GPIB cable.
 - d. Power on the analyzer and the generator.
 - e. Set the GPIB address of the generator to 1.
 - f. Insert the SG flatness floppy disk into the analyzer disk drive.

2. *Let the instruments warm up:* Allow a 20 minute warm-up period before you go to the next step.
3. *Execute the calibration:*
 - a. Press **CONFIG:Mode** → **Load** → **Dir** and select the directory *Bin* using the general purpose knob.
 - b. Press **Expand Dir** → **File** and select the file *cal.cfd* using the general purpose knob.
 - c. Press **OK**.
 - d. Press **View:C** → **Cal A...** → **Execute All**.
4. *Check the calibration result:* The results are shown in View C. The numbers of Passes or Fails are indicated with the background color green or red, respectively.
5. *Disconnect the hookup:*
 - a. Remove the floppy disk by pressing the eject button.

NOTE. *If you plan to perform CAL B, beginning on the next page, do not power off the analyzer or the generator, and do not disconnect the cables.*

- b. Power off the analyzer and generator.
- c. Disconnect the N-N cable.
- d. Disconnect the GPIB cable.

CAL B This procedure executes the auto calibration CAL B.

Equipment Required	One signal generator (Item 2) One N-N cable (Item 8) One GPIB cable (Item 9)
Prerequisites	Refer to page 5-13.

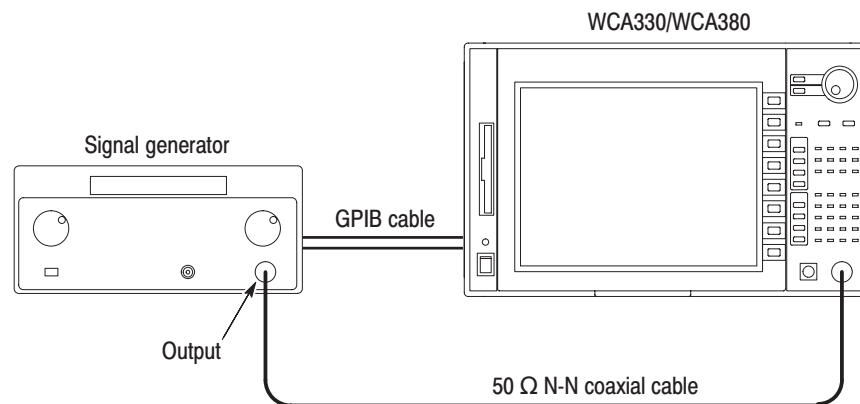


Figure 5-14: Initial test hookup

1. *Install the test hookup and preset the instrument controls:*
 - a. Power off the WCA330/WCA380 analyzer and the signal generator.
 - b. Connect the generator output through a 50 Ω N-N coaxial cable to the analyzer **RF INPUT**. See Figure 5-14.
 - c. Connect the analyzer and the generator with a GPIB cable.
 - d. Power on the analyzer and the generator.
 - e. Set the GPIB address of the generator to 1.
2. *Let the instruments warm up:* Allow a 20 minute warm-up period before you go to the next step.

3. *Execute the calibration:*
 - a. Press **CONFIG:Mode** → **Load** → **Dir** and select the directory *Bin* using the general purpose knob.
 - b. Press **Expand Dir** → **File** and select the file *cal.cfd* using the general purpose knob.
 - c. Press **OK**.
 - d. Press **View:C** → **Cal B...** → **Execute All**.
4. *Check the calibration result:* The results are shown in View C. The numbers of Passes or Fails are indicated with the background color green or red, respectively.
5. *Disconnect the hookup:*
 - a. Disconnect the N-N cable.
 - b. Power off the analyzer and generator.
 - c. Disconnect the GPIB cable.

CAL C This procedure executes the auto calibration CAL C using the internal signal generator.

Equipment Required	None
Prerequisites	Refer to page 5-13.

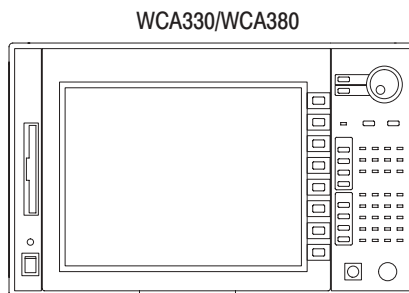


Figure 5-15: Initial test hookup

1. *Install the test hookup and preset the instrument controls:*
 - Power on the WCA330/WCA380 analyzer.
2. *Let the instruments warm up:* Allow a 20 minute warm-up period before you go to the next step.
3. *Execute the calibration:*
 - a. Press **CONFIG:Mode** → **Load** → **Dir** and select the directory *Bin* using the general purpose knob.
 - b. Press **Expand Dir** → **File** and select the file *cal.cfd* using the general purpose knob.
 - c. Press **OK**.
 - d. Press **View:C** → **Cal C...** → **Execute All**.
4. *Check the calibration result:* The results are shown in View C. The numbers of Passes or Fails are indicated with the background color green or red, respectively.
5. *Disconnect the hookup:*
 - Power off the analyzer.

CAL D This procedure executes the auto calibration CAL D.

Equipment Required	One signal generator (Item 2) One N-N cable (Item 8) One GPIB cable (Item 9)
Prerequisites	Refer to page 5-13.

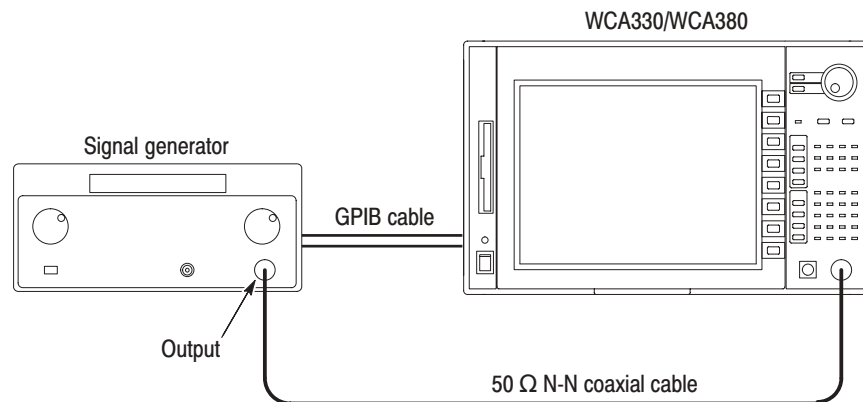


Figure 5-16: Initial test hookup

1. *Install the test hookup and preset the instrument controls:*
 - a. Power off the WCA330/WCA380 analyzer and the signal generator.
 - b. Connect the generator output through a 50 Ω N-N coaxial cable to the analyzer **RF INPUT**. See Figure 5-16.
 - c. Connect the analyzer and the generator with a GPIB cable.
 - d. Power on the analyzer and the generator.
 - e. Set the GPIB address of the generator to 1.
2. *Let the instruments warm up:* Allow a 20 minute warm-up period before you go to the next step.

3. *Execute the calibration:*
 - a. Press **CONFIG:Mode** → **Load** → **Dir** and select the directory *Bin* using the general purpose knob.
 - b. Press **Expand Dir** → **File** and select the file *cal.cfd* using the general purpose knob.
 - c. Press **OK**.
 - d. Press **View:C** → **Cal D...** → **Execute All**.
4. *Check the calibration result:* The results are shown in View C. The numbers of Passes or Fails are indicated with the background color green or red, respectively.
5. *Disconnect the hookup:*
 - a. Power off the analyzer and generator.
 - b. Disconnect the N-N cable and the GPIB cable.

CAL E This procedure executes the auto calibration CAL E.

Equipment Required	One waveform generator (Item 4) Two BNC cables (Item 7) One GPIB cable (Item 9)
Prerequisites	Refer to page 5-13. Setup files must be installed to the waveform generator (refer to page 5-14).

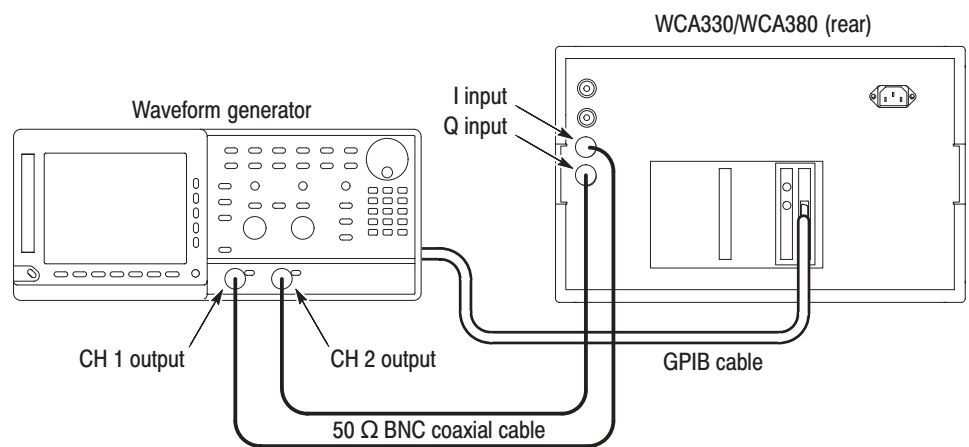


Figure 5-17: Initial test hookup

1. *Install the test hookup and preset the instrument controls:*
 - a. Power off the WCA330/WCA380 analyzer and waveform generator.
 - b. Connect the CH 1 output of the generator through a 50 Ω BNC coaxial cable to the **I INPUT** connector on the analyzer rear panel. See Figure 5-17.

NOTE. Make sure that the two BNC cables for I and Q signal connections have the same length.

CAL F This procedure executes the auto calibration CAL F.

Equipment Required	One waveform generator (Item 4) One BNC cables (Item 7) One GPIB cable (Item 9) One female BNC to male N adapter (Item 12)
Prerequisites	Refer to page 5-13. Setup files must be installed to the waveform generator (refer to page 5-14).

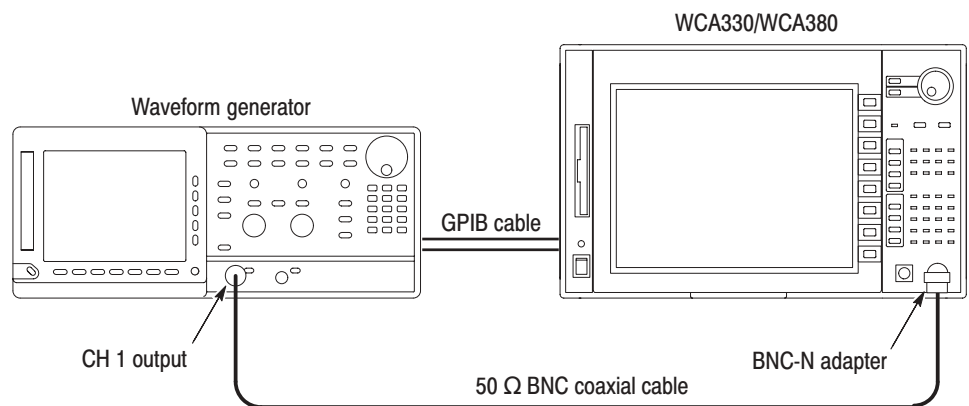


Figure 5-18: Initial test hookup

1. *Install the test hookup and preset the instrument controls:*
 - a. Power off the WCA330/WCA380 analyzer and waveform generator.
 - b. Connect the generator CH 1 output through a 50 Ω BNC coaxial cable to the analyzer **RF INPUT**. See Figure 5-18.
 - c. Connect the analyzer and the generator with a GPIB cable.
 - d. Power on the analyzer and the generator.
 - e. Set the GPIB address of the generator to 3.
2. *Let the instruments warm up:* Allow a 20 minute warm-up period before you go to the next step.

3. *Execute the calibration:*
 - a. Press **CONFIG:Mode** → **Load** → **Dir** and select the directory *Bin* using the general purpose knob.
 - b. Press **Expand Dir** → **File** and select the file *cal.cfd* using the general purpose knob.
 - c. Press **OK**.
 - d. Press **View:C** → **Cal F...** → **Execute All**.
4. *Check the calibration result:* The results are shown in View C. The numbers of Passes or Fails are indicated with the background color green or red, respectively.
5. *Disconnect the hookup:*
 - a. Power off the analyzer and generator.
 - b. Disconnect the BNC cable and GPIB cable.

CAL G (WCA380 Only)

This procedure executes the auto calibration CAL G for the WCA380 analyzer.

Equipment Required	One microwave signal generator (Item 3) One N-N cable (Item 8) One GPIB cable (Item 9) One MSG flatness floppy disk (Item 15)
Prerequisites	Refer to page 5-13.

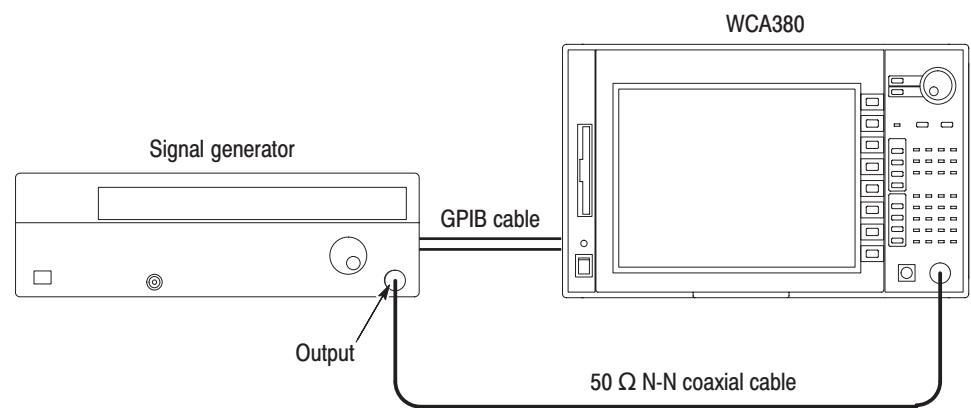


Figure 5-19: Initial test hookup

1. *Install the test hookup and preset the instrument controls:*
 - a. Power off the WCA380 analyzer and the signal generator.
 - b. Connect the generator output through a 50 Ω N-N coaxial cable to the analyzer **RF INPUT**. See Figure 5-19.
 - c. Connect the analyzer and the generator with a GPIB cable.
 - d. Power on the analyzer and the generator.
 - e. Set the GPIB address of the generator to 5.
 - f. Insert the MSG flatness floppy disk into the analyzer disk drive.
2. *Let the instruments warm up:* Allow a 20 minute warm-up period before you go to the next step.

3. *Execute the calibration:*
 - a. Press **CONFIG:Mode** → **Load** → **Dir** and select the directory *Bin* using the general purpose knob.
 - b. Press **Expand Dir** → **File** and select the file *cal.cfd* using the general purpose knob.
 - c. Press **OK**.
 - d. Press **View:C** → **Cal G...** → **Execute All**.
4. *Check the calibration result:* The results are shown in View C. The numbers of Passes or Fails are indicated with the background color green or red, respectively.
5. *Disconnect the hookup:*
 - a. Power off the analyzer and generator.
 - b. Disconnect the N-N cable and the GPIB cable.

Backing Up Calibration Files

You can back up the files in which the internal calibration routines store the correction factors. Copy these text files to a floppy disk:

WCA330 calibration files	24 files (total 489 Kbytes)
WCA380 calibration files	39 files (total 852 Kbytes)

Directory: C:\Program Files\SONY Tektronix\wca\Sys

Copying the Calibration Files. To copy the files, follow these steps:

1. Insert a floppy disk into the analyzer floppy disk drive.
2. Press **CONFIG:Mode** → **Load** → **Dir** and select the directory *Bin* using the general purpose knob.
3. Press **Expand Dir** → **File** and select the file *cal.cfd* using the general purpose knob.
4. Press **OK**.
5. Do either or both of these steps to save the calibration files:
 - To save the files to a floppy disk, press View:C → **Copy Results To Floppy**.
 - To save the files to the flash disk (drive D:), press View:C → **Copy Results To DiskOnChip**.

Restoring the Calibration Files. To restore the files, follow these steps:

1. Connect a mouse to the analyzer. Refer to *Connecting the Mouse* on page 2–5.
2. Turn on the analyzer.
3. Insert the floppy disk into the analyzer floppy disk drive.
4. Access Windows 98:
 - a. Use a mouse to move the pointer to the bottom of the display (see Figure 5–20). The task bar appears.
 - b. Locate the pointer on the **WCA330** or **WCA380** icon in the task bar and right-click. A menu appears.
 - c. Select **Close** in the menu. The system program of the analyzer terminates and a Windows 98 desktop screen appears.

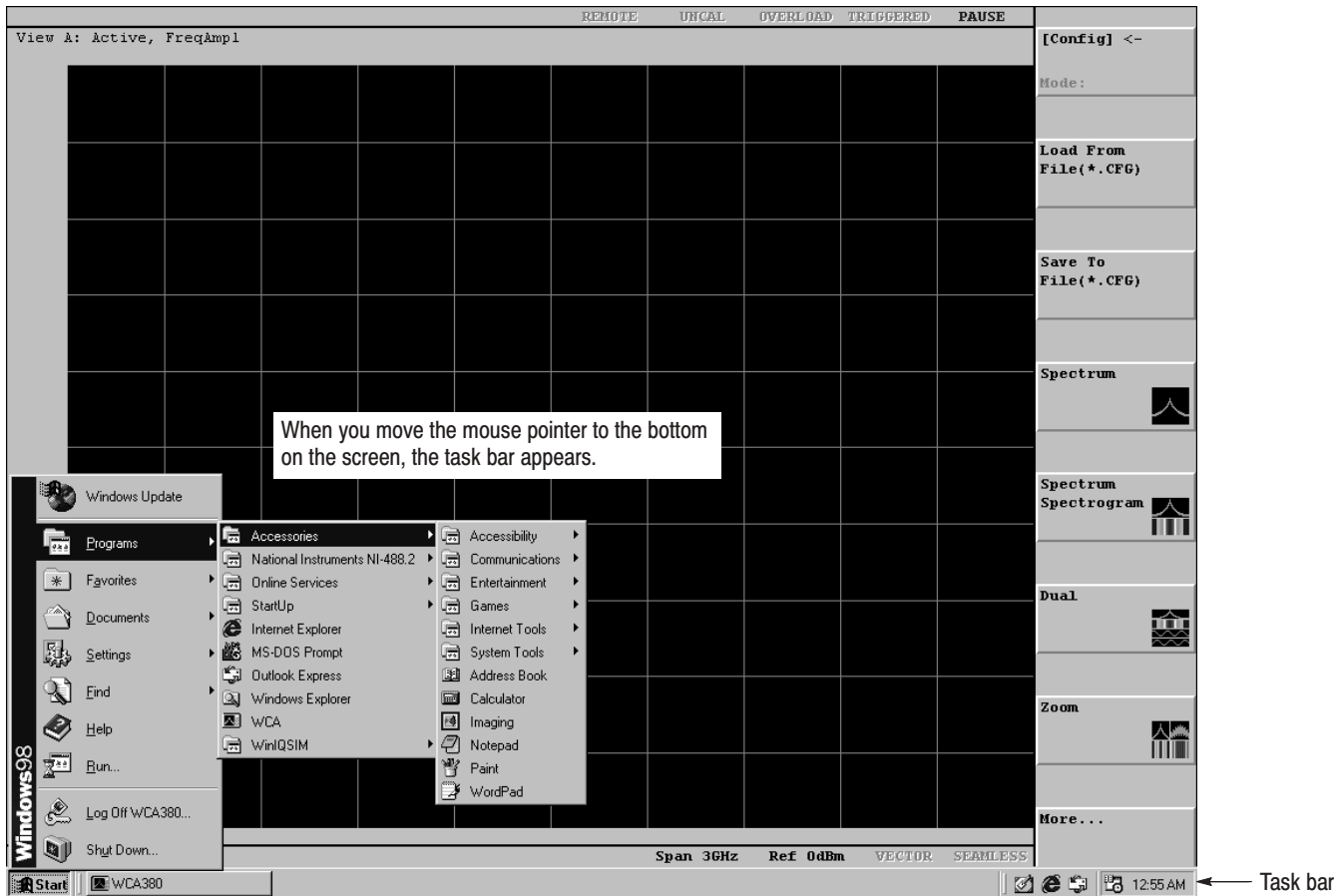


Figure 5-20: Displaying the Windows 98 accessory menu

5. Restore the calibration files from the floppy disk or flash disk to the directory *C:\Program Files\SONY Tektronix\wca\Sys* using Windows Explorer.
6. When you have finished copying files, close all windows.
7. Select **Start** → **Programs** → **WCA** from the task bar to restart the analyzer.

Maintenance

Maintenance

This section contains the information needed to do periodic and corrective maintenance on the WCA330 and WCA380 Wireless Communication Analyzers. The following subsections are included:

- *Preparation* — Introduction plus general information on preventing damage to internal modules when doing maintenance.
- *Inspection and Cleaning* — Information and procedures for inspecting the analyzer and cleaning its external and internal modules.
- *Removal and Installation Procedures* — Procedures for the removal of defective modules and replacement of new or repaired modules. Also included is a procedure for disassembly of the analyzer for cleaning.
- *Troubleshooting* — Information for isolating and troubleshooting failed modules. Included are instructions for operating the analyzer's internal diagnostic routines and troubleshooting trees.

Related Maintenance Procedures

The following sections contain information and procedures related to maintenance.

- Section 2, *Operating Information*, covers instructions useful when operating the analyzer in order to troubleshoot it. It also details the service strategy and lists options for obtaining maintenance service and for replacing failed modules.
- Section 3, *Theory of Operation*, contains a circuit description at the module, or block, level.
- Section 4, *Performance Verification*, contains procedures that may be useful in isolating problems to modules by testing analyzer performance.
- Section 5, *Adjustment Procedures*, addresses after repair adjustment and the interval between periodic adjustments. Procedures for adjusting the analyzer are included in this section.
- Section 9, *Diagrams*, contains a block diagram using individual modules as blocks and an interconnection diagram showing connections between modules.
- Section 10, *Mechanical Parts List*, lists all field replaceable modules by part number.

Preparation

Before servicing this product, read the *Safety Summary* and *Introduction* at the front of the manual and the ESD information below.



CAUTION. *Static discharge can damage any semiconductor component in this analyzer.*

Preventing ESD

When performing any service which requires internal access to the analyzer, adhere to the following precautions to avoid damaging internal modules and their components due to electrostatic discharge (ESD).

1. Minimize handling of static-sensitive modules.
2. Transport and store static-sensitive modules in their static protected containers or on a metal rail. Label any package that contains static-sensitive modules.
3. Discharge the static voltage from your body by wearing a grounded antistatic wrist strap while handling these modules. Do service of static-sensitive modules only at a static-free work station.
4. Nothing capable of generating or holding a static charge should be allowed on the work station surface.
5. Handle circuit boards by the edges when possible.
6. Do not slide the modules over any surface.
7. Avoid handling modules in areas that have a floor or work-surface covering capable of generating a static charge.

Susceptibility to ESD

Table 6–1 lists the relative susceptibility of various classes of semiconductors. Static voltages of 1 kV to 30 kV are common in unprotected environments.

Table 6–1: Relative susceptibility to static-discharge damage

Semiconductor classes	Relative susceptibility levels¹
MOS or CMOS microcircuits or discrete circuits, or linear microcircuits with MOS inputs (most sensitive)	1
ECL	2
Schottky signal diodes	3
Schottky TTL	4
High-frequency bipolar transistors	5
JFET	6
Linear microcircuits	7
Low-power Schottky TTL	8
TTL (least sensitive)	9

¹ **Voltage equivalent for levels (voltage discharged from a 100 pF capacitor through resistance of 100 ohms):**

1 = 100 to 500 V	6 = 600 to 800 V
2 = 200 to 500 V	7 = 400 to 1000 V (est.)
3 = 250 V	8 = 900 V
4 = 500 V	9 = 1200 V
5 = 400 to 600 V	

Inspection and Cleaning

Inspection and Cleaning describes how to inspect for dirt and damage. It also describes how to clean the exterior and interior of the analyzer. Inspection and cleaning are done as preventive maintenance. Preventive maintenance, when done regularly, may prevent analyzer malfunction and enhance its reliability.

Preventive maintenance consists of visually inspecting and cleaning the analyzer and using general care when operating it.

How often to do maintenance depends on the severity of the environment in which the analyzer is used. A proper time to perform preventive maintenance is just before analyzer adjustment.

General Care

The cabinet helps keep dust out of the analyzer and should normally be in place when operating the analyzer.

Inspection and Cleaning Procedures

Inspect and clean the analyzer as often as operating conditions require. The collection of dirt on components inside can cause them to overheat and breakdown. (Dirt acts as an insulating blanket, preventing efficient heat dissipation.) Dirt also provides an electrical conduction path that could cause an analyzer failure, especially under high-humidity conditions.



CAUTION. *Avoid the use of chemical cleaning agents which might damage the plastics used in this analyzer. Use only deionized water when cleaning the menu buttons or front-panel buttons. Use a 75% isopropyl alcohol solution as a cleaner and rinse with deionized water. Before using any other type of cleaner, consult your Tektronix Service Center or representative.*

Inspection — Exterior. Inspect the outside of the analyzer for damage, wear, and missing parts, using Table 6–2 as a guide. Analyzers that appear to have been dropped or otherwise abused should be checked thoroughly to verify correct operation and performance. Immediately repair defects that could cause personal injury or lead to further damage to the analyzer.

Table 6–2: External inspection check list

Item	Inspect for	Repair action
Cabinet, front panel, and cover	Cracks, scratches, deformations, damaged hardware or gaskets.	Repair or replace defective module.
Front-panel knobs	Missing, damaged, or loose knobs.	Repair or replace missing or defective knobs.
Connectors	Broken shells, cracked insulation, and deformed contacts. Dirt in connectors.	Repair or replace defective modules. Clear or wash out dirt.
Carrying handle, bail, cabinet feet.	Correct operation.	Repair or replace defective module.
Accessories	Missing items or parts of items, bent pins, broken or frayed cables, and damaged connectors.	Repair or replace damaged or missing items, frayed cables, and defective modules.

Cleaning Procedure — Exterior. To clean the analyzer exterior, do the following steps:

1. Remove loose dust on the outside of the analyzer with a lint free cloth.
2. Remove remaining dirt with a lint free cloth dampened in a general purpose detergent-and-water solution. Do not use abrasive cleaners.
3. Clean the light filter protecting the monitor screen with a lint-free cloth dampened with either isopropyl alcohol or, preferably, a gentle, general purpose detergent-and-water solution.



CAUTION. To prevent getting moisture inside the analyzer during external cleaning, use only enough liquid to dampen the cloth or applicator.

Inspection — Interior. To access the inside of the analyzer for inspection and cleaning, refer to the *Removal and Installation Procedures* in this section.

Inspect the internal portions of the analyzer for damage and wear, using Table 6–3 as a guide. Defects found should be repaired immediately.



CAUTION. To prevent damage from electrical arcing, ensure that circuit boards and components are dry before applying power to the analyzer.

Table 6–3: Internal inspection check list

Item	Inspect for	Repair action
Circuit boards	Loose, broken, or corroded solder connections. Burned circuit boards. Burned, broken, or cracked circuit-run plating.	Remove failed module and replace with a fresh module.
Resistors	Burned, cracked, broken, blistered condition.	Remove failed module and replace with a fresh module.
Solder connections	Cold solder or rosin joints.	Resolder joint and clean with isopropyl alcohol.
Capacitors	Damaged or leaking cases. Corroded solder on leads or terminals.	Remove damaged module and replace with a fresh module from the factory.
Semiconductors	Loosely inserted in sockets. Distorted pins.	Firmly seat loose semiconductors. Remove devices that have distorted pins. Carefully straighten pins (as required to fit the socket), using long-nose pliers, and reinsert firmly. Ensure that straightening action does not crack pins, causing them to break off.
Wiring and cables	Loose plugs or connectors. Burned, broken, or frayed wiring.	Firmly seat connectors. Repair or replace modules with defective wires or cables.
Chassis	Dents, deformations, and damaged hardware.	Straighten, repair, or replace defective hardware.

Cleaning Procedure — Interior. To clean the analyzer interior, do the following steps:

1. Blow off dust with dry, low-pressure, deionized air (approximately 9 psi).
2. Remove any remaining dust with a lint-free cloth dampened in isopropyl alcohol (75% solution) and rinse with warm deionized water. (A cotton-tipped applicator is useful for cleaning in narrow spaces and on circuit boards.)

STOP. *If, after doing steps 1 and 2, a module is clean upon inspection, skip the remaining steps.*

3. If steps 1 and 2 do not remove all the dust or dirt, the analyzer may be spray washed using a solution of 75% isopropyl alcohol by doing steps 4 through 8.
4. Gain access to the parts to be cleaned by removing easily accessible shields and panels (see *Removal and Installation Procedures*).
5. Spray wash dirty parts with the isopropyl alcohol and wait 60 seconds for the majority of the alcohol to evaporate.
6. Use hot (120° F to 140° F) deionized water to thoroughly rinse them.
7. Dry all parts with low-pressure, deionized air.
8. Dry all components and assemblies in an oven or drying compartment using low-temperature (125° F to 150° F) circulating air.

Lubrication. There is no periodic lubrication required for this analyzer.

Removal and Installation Procedures

This subsection contains procedures for removal and installation of all mechanical and electrical modules. Any electrical or mechanical assembly, or part listed in Section 10 of this manual is a module.

Preparation



WARNING. Before doing this or any other procedure in this manual, read the Safety Summary found at the beginning of this manual. Also, to prevent possible injury to service personnel or damage to this analyzer's components, read Installation in Section 2, and Preventing ESD in this section.

This subsection contains the following items:

- This preparatory information that you need to properly do the procedures that follow.
- List of tools required to remove and disassemble all modules.
- Six module locator diagrams for finding the External modules (see Figure 6-2), Inner-chassis modules (see Figure 6-3), Power supply modules (see Figure 6-4), Mother board and its daughter boards (see Figure 6-5), Front panel modules (see Figure 6-6), and Rear chassis modules (see Figure 6-7) in this analyzer.
- Procedures for removal and reinstallation of the electrical and mechanical modules.
- A disassembly procedure for removal of all the major modules from the analyzer at one time and for reassembly of those modules into the analyzer. Such a complete disassembly is normally only done when completely cleaning the analyzer. (Instructions for doing the actual cleaning are found under *Inspection and Cleaning* at the beginning of this section.)



WARNING. Before doing any procedure in this subsection, disconnect the power cord from the line voltage source. Failure to do so could cause serious injury or death.

List of Modules Section 10 lists all modules.

General Instructions

STOP. READ THESE GENERAL INSTRUCTIONS BEFORE REMOVING A MODULE.

First read over the Summary of Procedures that follows to understand how the procedures are grouped. Then read Equipment Required for a list of the tools needed to remove and install modules in this analyzer.

If you are removing a module for service, begin by doing the procedure Access Procedure (page 6–19). By following the instructions in that procedure, you remove the module to be serviced while removing the minimum number of additional modules.

Summary of Procedures

The procedures are described in the order in which they appear in this section. In addition, you can look up any procedure for removal and reinstallation of any module in the *Table of Contents* of this manual.

- The *Access Procedure* on page 6–19 first directs you to the procedure(s) (if any) that are required to access the module to be serviced, then it directs you to the procedure to remove that module.

Table 6–4: Summary of procedures

Procedure	Module	Page
Procedures for External Modules	<ul style="list-style-type: none"> ■ Line cord ■ Cabinet ■ Foot ■ Handle 	6–20
Procedures for Inner-Chassis Modules	<ul style="list-style-type: none"> ■ A12 IF gain board ■ A13 IF A/D board ■ Down converter unit 1 ■ Down converter unit 2 ■ Fan ■ Hard disk drive ■ Floppy disk drive 	6–24
Procedures for Power Supply Modules	<ul style="list-style-type: none"> ■ Standby power supply ■ Power supply ■ AC line filter ■ Heat sink ■ A70 DC Power-1 board ■ A71 DC Power-2 board ■ A72 DC Power-3 board 	6–36
Procedures for Mother Board and its Daughter Boards	<ul style="list-style-type: none"> ■ A20 DDC board ■ A22 Wide ADC board ■ A30 FFT board ■ A40 Memory board ■ A50 Mother board ■ CPU board ■ Video board ■ GPIB board 	6–44
Procedures for Front-Panel Modules	<ul style="list-style-type: none"> ■ Front panel assembly ■ Display unit ■ Left front-panel ■ Right front-panel 	6–52
Procedures for Rear-Chassis Modules	<ul style="list-style-type: none"> ■ Fan ■ Receptacle ■ Rear connectors 	6–59

Equipment Required. Most modules in this analyzer can be removed with a screwdriver with a size #2, Phillips tip. *Use this tool whenever a procedure step instructs you to remove or install a screw unless a different size screwdriver is specified in that step.* All equipment required to remove and reinstall a module are listed in the first step of each procedure.

Table 6-5: Tools required for module removal

Item No.	Name	Description	Tektronix part number
1	Screwdriver handle	Accepts $\frac{1}{4}$ inch hex-head driver tips	
2	#1 Phillips tip	Phillips-driver bit for #1 size screw heads	
3	#2 Phillips tip	Phillips-driver bit for #2 size screw heads	
4	No. 2 Pozidrive tip	Pozidrive-driver bit for number 2 size screw heads	
5	Flat-bladed screwdriver	Screwdriver for removing standard-headed screws	
6	Nutdriver, $\frac{1}{4}$ inch	Standard tool	
7	Nutdriver, $\frac{9}{16}$ inch	Standard tool	
8	Nutdriver, 5.5 mm	Standard tool	
9	Nutdriver, 7 mm	Standard tool	
10	Nutdriver, 12 mm	Standard tool	
11	Wrench, $\frac{1}{16}$ inch	Standard tool	
12	Wrench, $\frac{5}{16}$ inch	Standard tool	
13	Angle-tip tweezers	Standard tool	
14	Pliers	Standard tool	
15	Soldering iron	Standard tool	
16	Solder wick	Standard tool	
17	Adhesive	TRA-CON: Tra-Bond #BA-2114	

Analyzer Orientation

In this manual, procedures refer to “front,” “right,” “top,” etc. of the analyzer. Figure 6–1 shows how the sides are referenced.

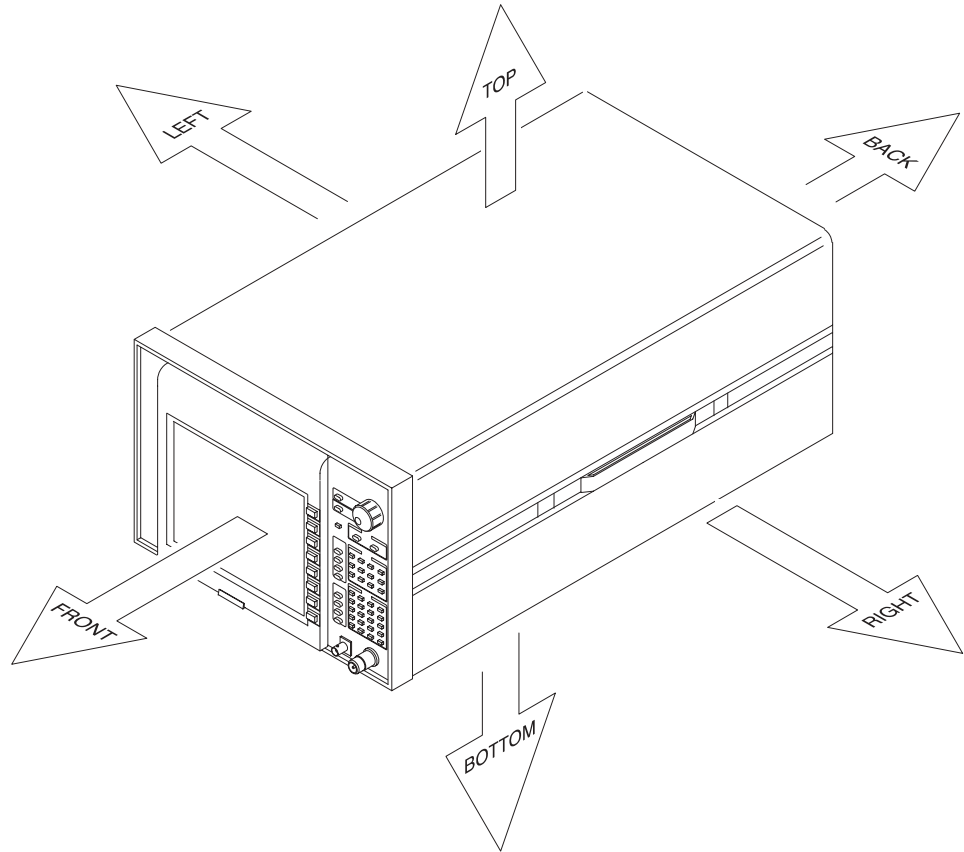


Figure 6-1: Analyzer orientation

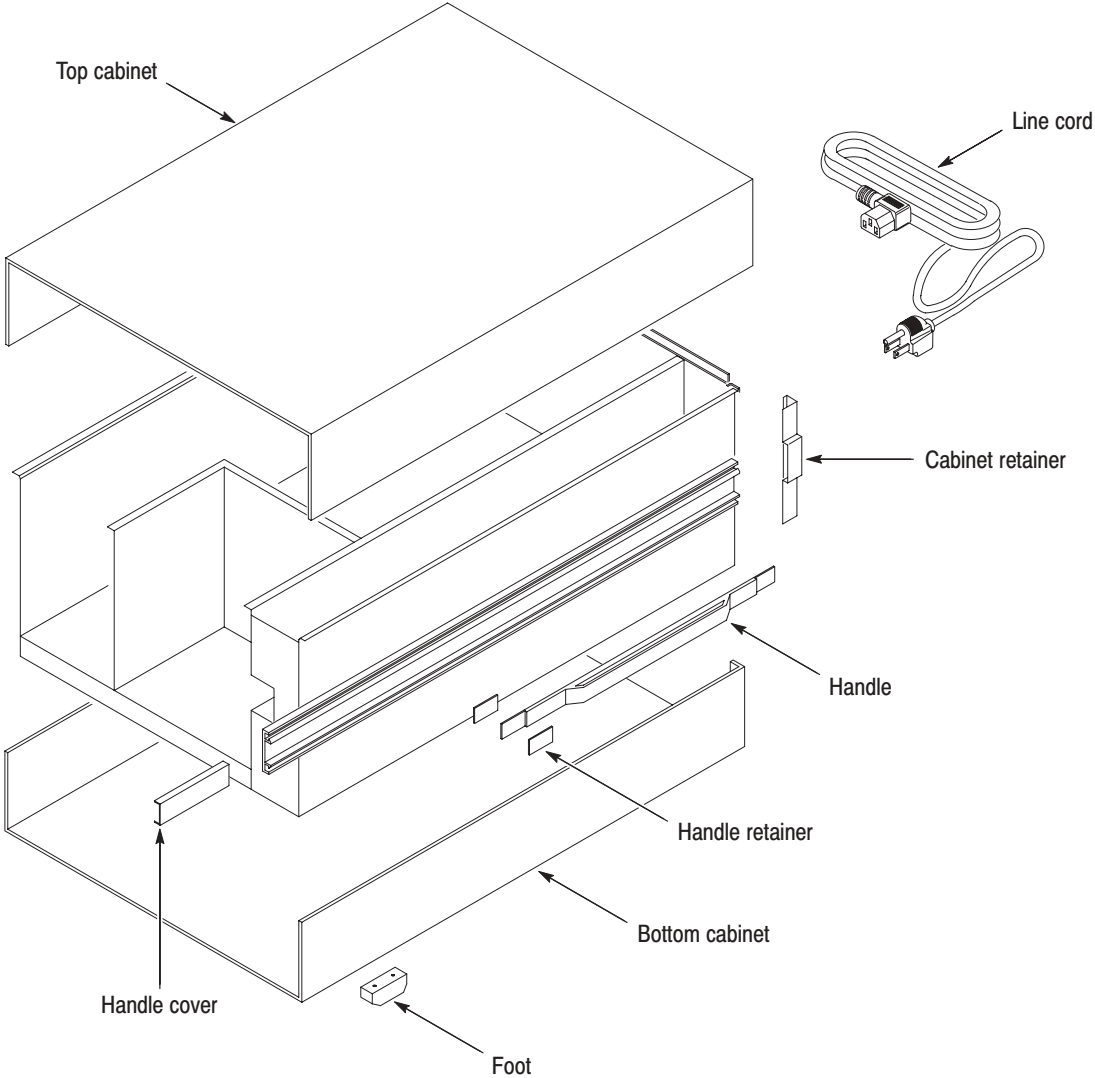


Figure 6-2: External modules

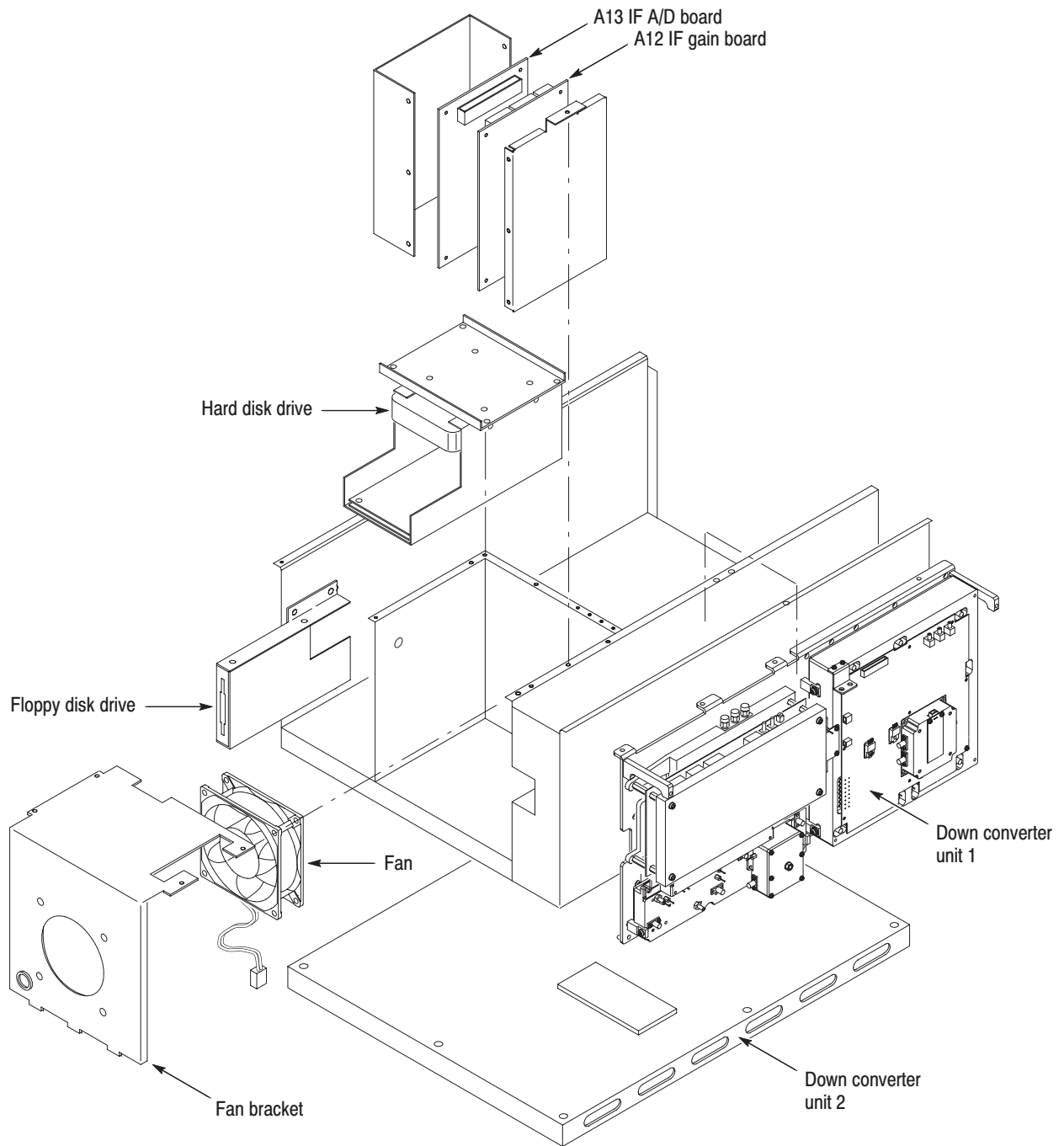


Figure 6-3: Inner-chassis modules

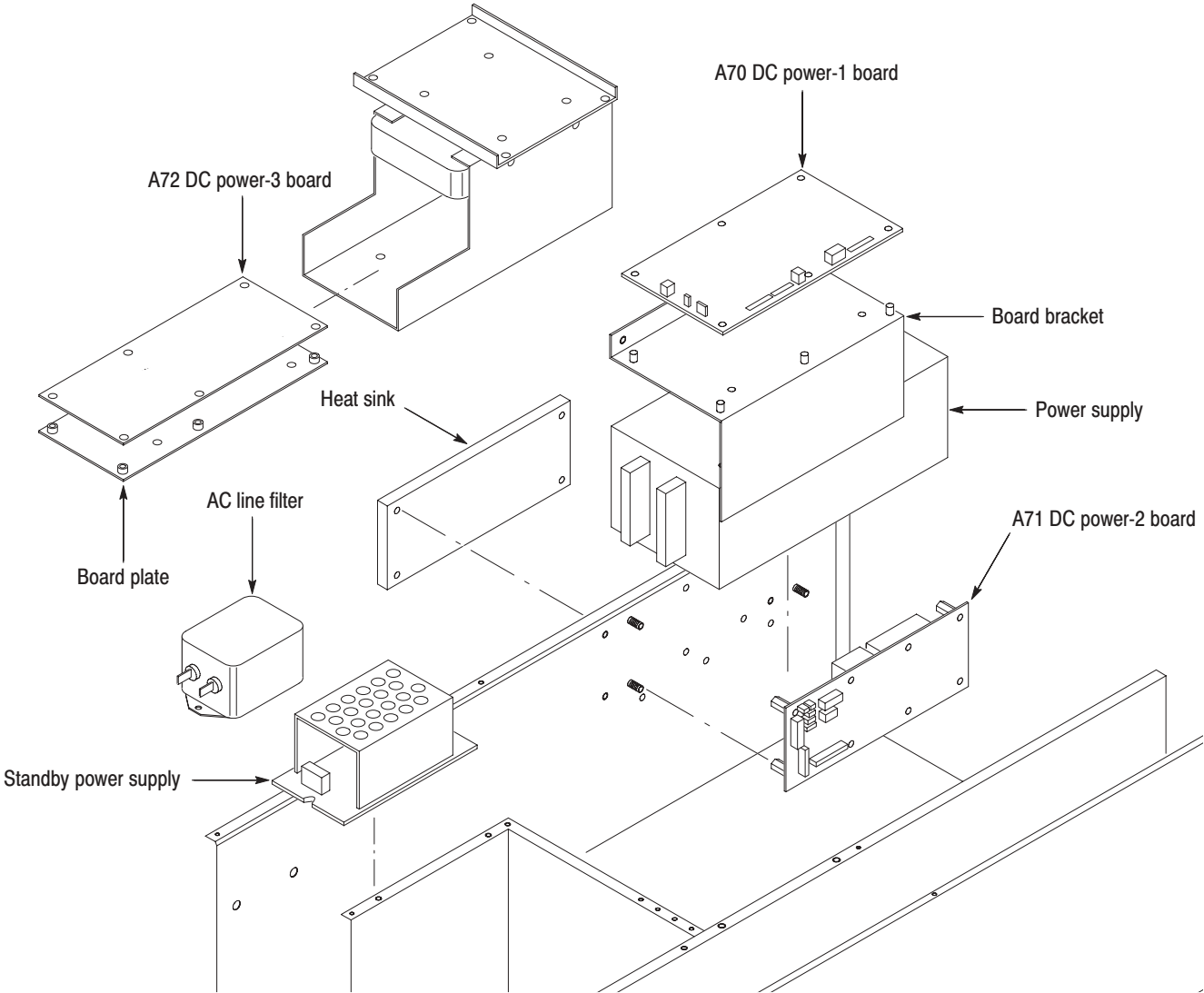


Figure 6-4: Power supply modules

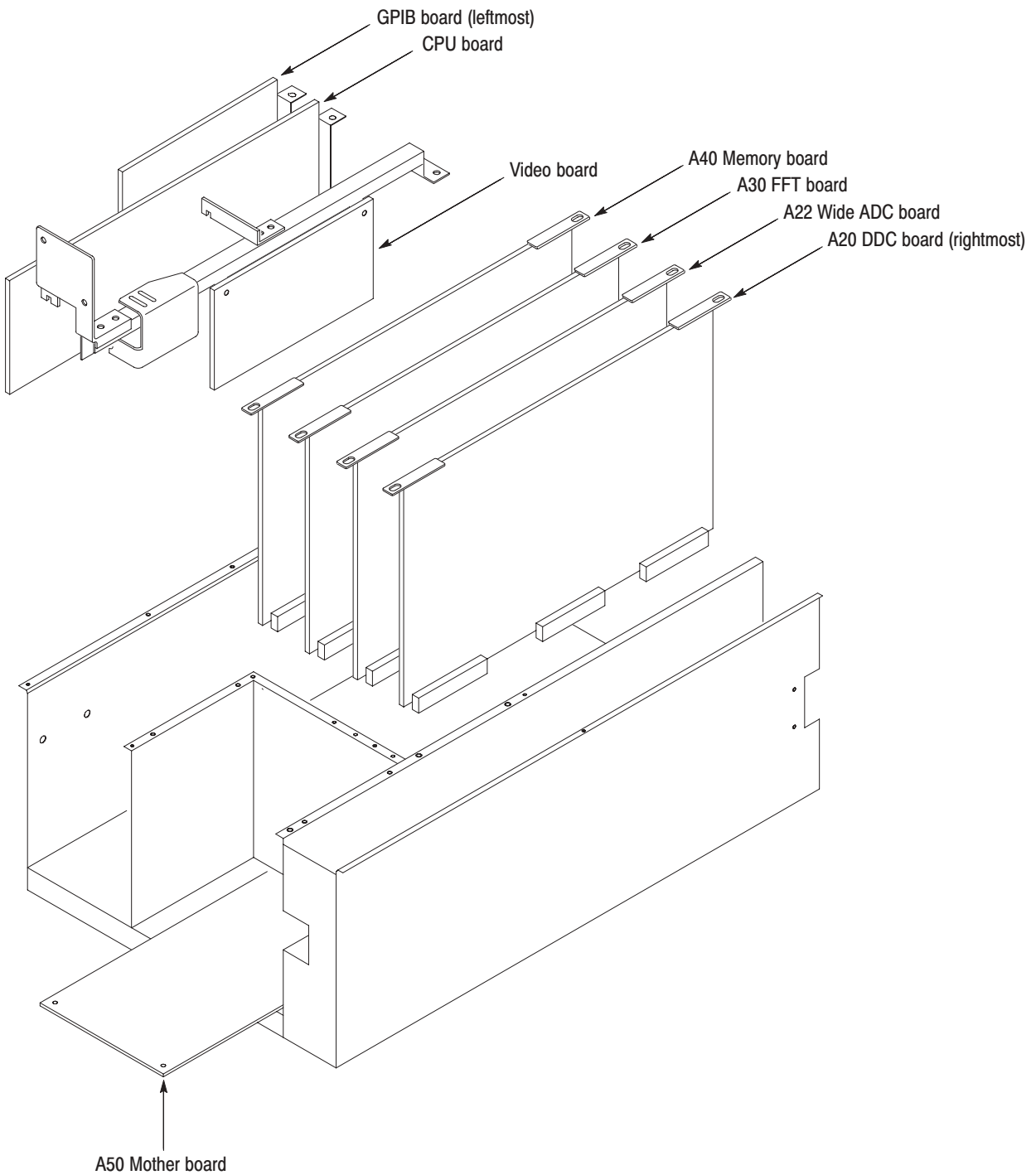


Figure 6-5: Mother board and its daughter boards

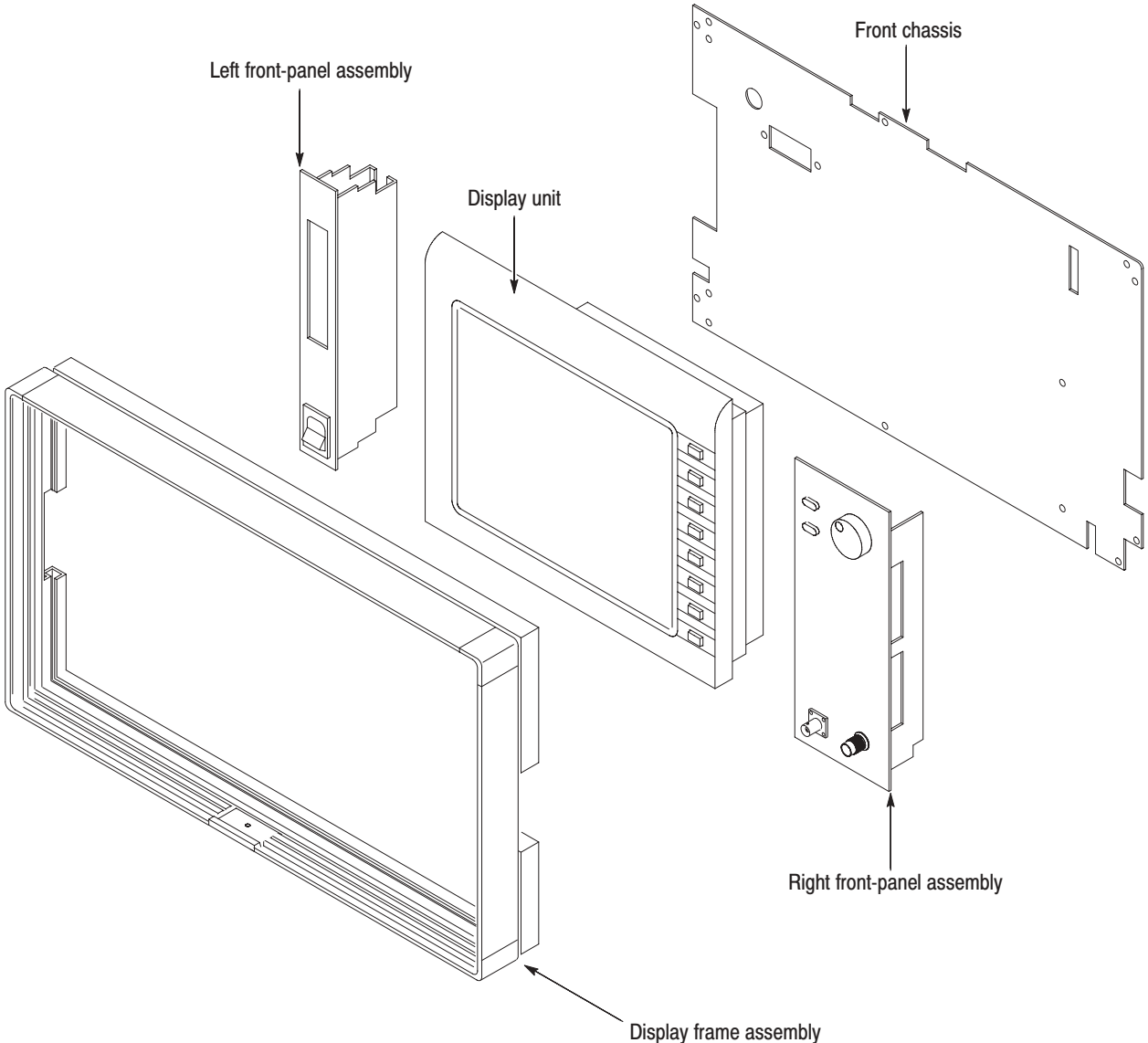


Figure 6-6: Front panel modules

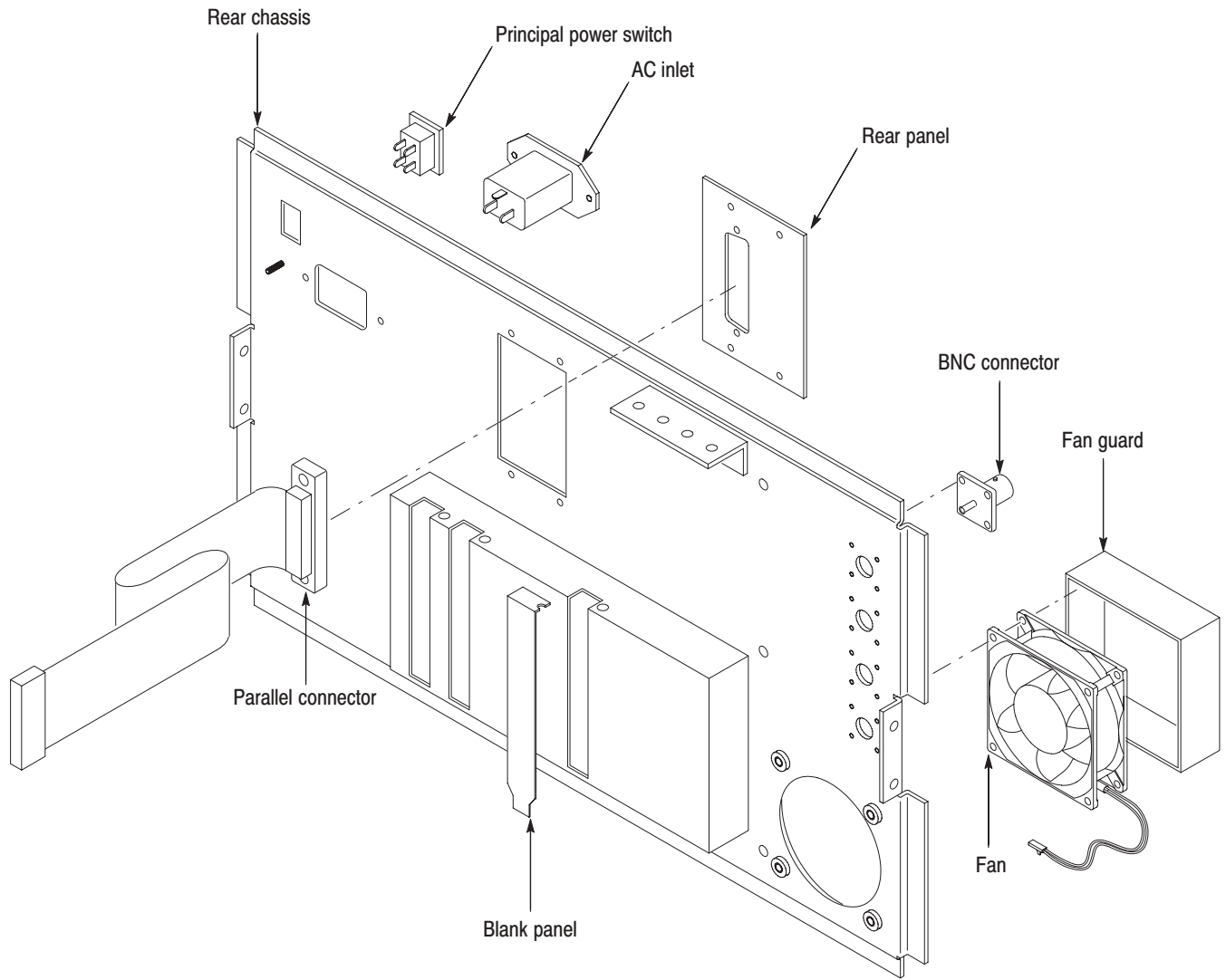


Figure 6-7: Rear chassis modules

Access Procedure

When you have identified the module to be removed for service, read *General Instructions* found earlier in this section. Then use the flowchart in Figure 6-8 to determine which procedures to use for removing the module. The removal procedures end with reinstallation instructions.

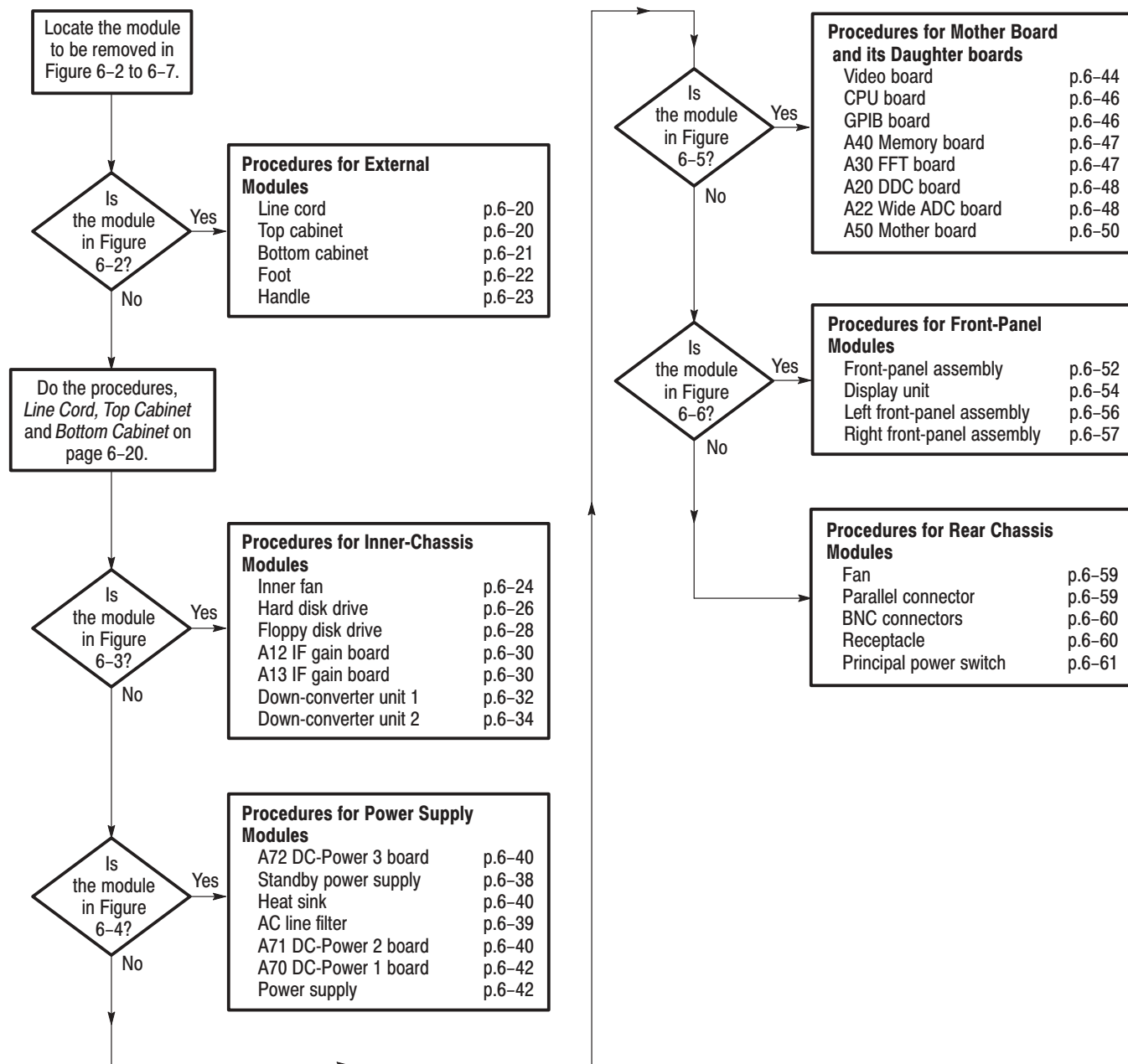


Figure 6-8: Guide to removal procedures

Procedures for External Modules

Do the *Access Procedure* (page 6–19) before doing any procedure in this collection. The following procedures are found here and are listed in order presented.

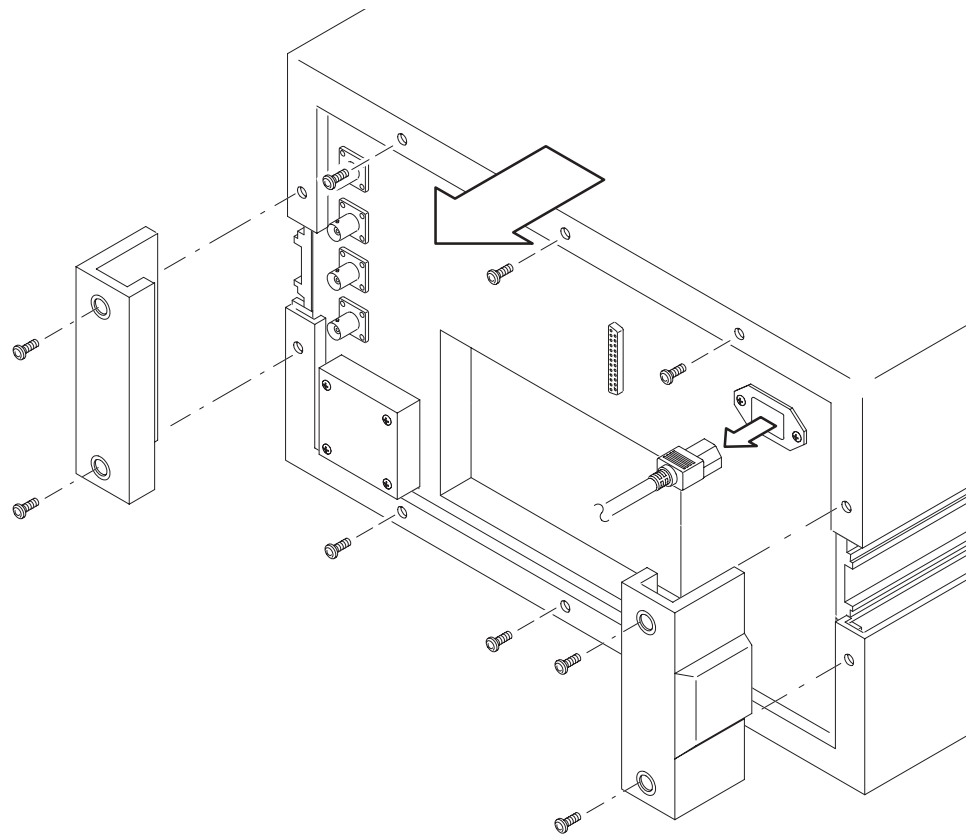
- *Line Cord*
- *Top Cabinet*
- *Bottom Cabinet*
- *Foot*
- *Handle*

- Line Cord**
1. *Assemble equipment and locate modules to be removed:* Locate the line cord in the locator diagram *External Modules*, Figure 6–2.
 2. *Orient the analyzer:* Position the analyzer so its bottom is down on the work surface and the rear panel is facing you.
 3. *Remove the line cord:* Find the line cord on the rear cover. See Figure 6–9. Pull the line cord away to complete the removal.
 4. *Reinstallation:* Reinstall the line cord by performing step 3 in reverse.

- Top Cabinet**
1. *Assemble equipment and locate modules to be removed:*
 - a. You will need a screwdriver with a size Phillips #1 tip (Items 1 and 2) to perform the following procedures.
 - b. Locate the cabinet in the *External Modules* diagram, Figure 6–2.
 2. *Orient the analyzer:* Position the analyzer so its bottom is down on the work surface and the rear panel is facing you.
 3. *Remove the top cabinet:* See Figure 6–9.
 - a. Remove the two screws securing the plastic cover to the rear panel at each side.
 - b. Remove the three screws securing the top cabinet to the rear panel.
 - c. Slide the cabinet backward. Take care not to bind or snag the cabinet on the analyzer's internal cabling as you remove it.
 4. *Reinstallation:* Reinstall the top cabinet by performing step 3 in reverse.

Bottom Cabinet

1. *Assemble equipment and locate modules to be removed:*
 - a. You will need a screwdriver with a size Phillips #1 tip (Items 1 and 2).
 - b. Locate the cabinet in the *External Modules* diagram, Figure 6-2.
2. *Orient the analyzer:* Set the analyzer so its top is down on the work surface and the rear panel is facing you.
3. *Remove the bottom cabinet:* See Figure 6-9.
 - a. Remove the two screws securing the plastic cover to the rear panel at each side.
 - b. Remove the three screws securing the bottom cabinet to the rear panel.
 - c. Slide the cabinet backward. Take care not to bind or snag the cabinet on the analyzer's internal cabling as you remove it.
4. *Reinstallation:* Reinstall the bottom cabinet by performing step 3 in reverse.

**Figure 6-9: Line cord and cabinet removal**

- Foot**
1. *Assemble equipment and locate modules to be removed:*
 - a. You will need a screwdriver with a size Phillips #2 tip (Items 1 and 3).
 - b. Locate the foot in the *External Modules* diagram, Figure 6-2.
 2. *Orient the analyzer:* Position the analyzer so its top is down on the work surface and the front panel is facing you.
 3. *Remove the foot:* Remove the two screws securing the foot to the bottom cabinet. See Figure 6-10.
 4. *Reinstallation:* Reinstall the foot by performing step 3 in reverse.

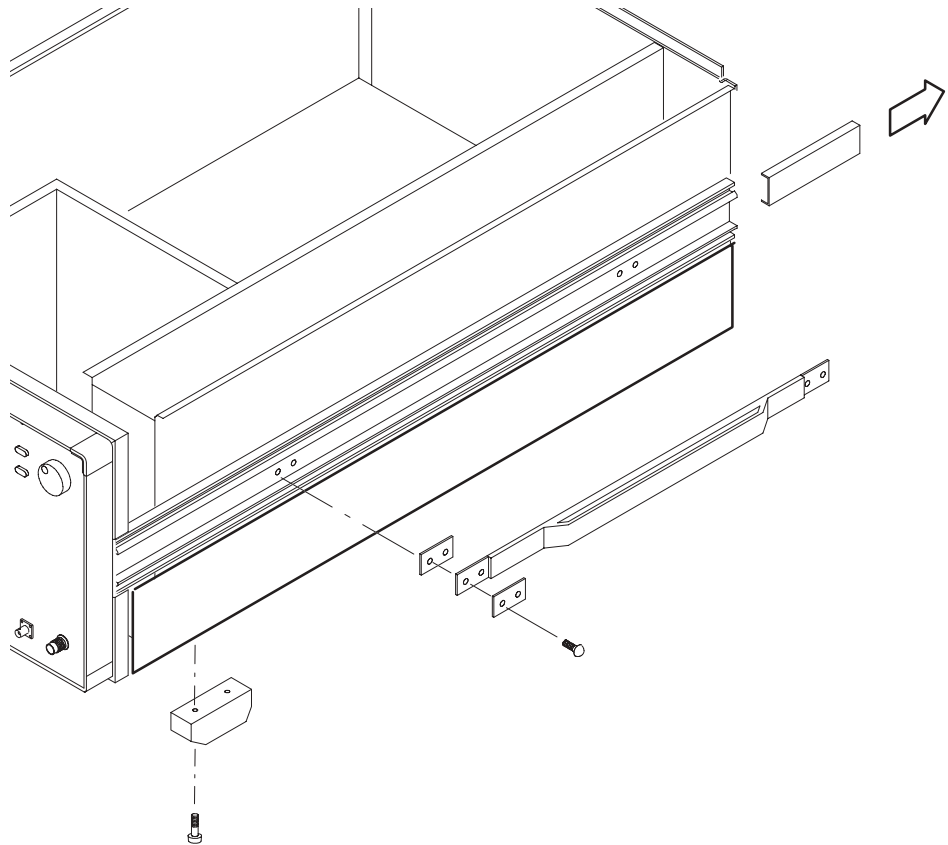


Figure 6-10: Handle and foot removal

- Handle**
1. *Assemble equipment and locate modules to be removed:*
 - a. You will need a screwdriver with a size No.2 Pozidrive tip (Items 1 and 4).
 - b. Locate the handle in the *External Modules* diagram, Figure 6-2.
 - c. Do the procedure *Top Cabinet* on page 6-20 to remove the plastic cover on the rear. It is **not** necessary to remove the cabinet.
 2. *Orient the analyzer:* Position the analyzer so the bottom is down on the work surface and the handle serviced is facing you.
 3. *Remove the handle:* See Figure 6-10.
 - a. Slide the handle cover out.
 - b. Remove the four screws securing the handle to the chassis.
 4. *Reinstallation:* Reinstall the handle by performing step 3 in reverse.

Procedures for Inner-Chassis Modules

You should have completed the *Access Procedure* before doing any procedure in this collection. The procedures found here, listed in order presented, follow.

- *Inner fan*
- *Hard disk drive*
- *Floppy disk drive*
- *A12 IF gain board and A13 IF A/D board*
- *Down converter unit 1*
- *Down converter unit 2*

Inner Fan

1. *Assemble equipment and locate module to be removed:*
 - a. You will need a screwdriver with a size Phillips #2 tip (Items 1 and 3) and a 7 mm nutdriver (Items 9).
 - b. Locate the fan in the locator diagram *Inner-Chassis Modules*, Figure 6-3, page 6-14.
2. *Orient the analyzer:* Position the analyzer so the bottom is down on the work surface and the front panel is facing you.
3. *Remove the bracket with the fan:* See Figure 6-11.
 - a. Remove the four screws securing the bracket to the main chassis and lift the bracket up.
 - b. Unplug the fan's power cable at J541 on the A71 DC Power-2 board.
4. *Remove the fan:* Using a 7 mm nutdriver, remove the four nuts securing the fan to the bracket. Lift the fan away from the bracket. See Figure 6-11.
5. *Reinstallation:* Reinstall the fan by performing step 3 and 4 in reverse.

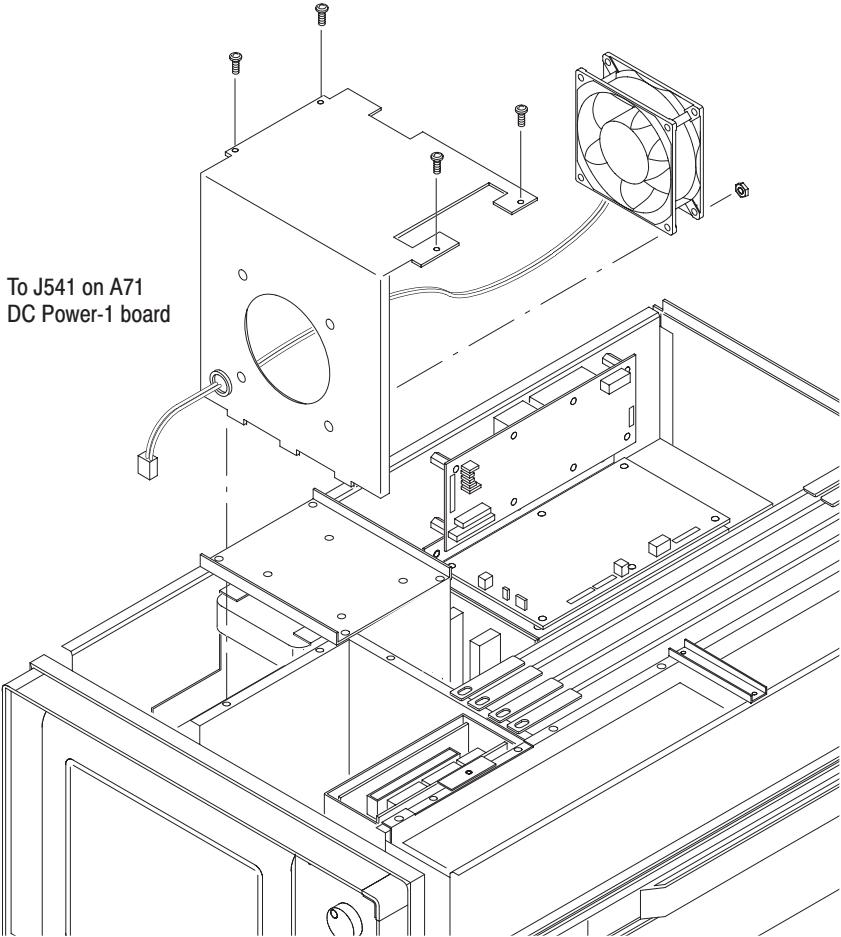


Figure 6-11: Inner fan removal

Hard Disk Drive

1. *Back up the user files:*

Use the Windows Back Up tool to back up files stored on the hard disk. The Back Up tool is located in the System Tools folder in the Accessories folder. Start the tool and determine which files and folders to back up. Use the Windows on-line help for information on using the Back Up tool.

For the analyzer, the user-generated files consist of configuration and data files, which have these extensions:

- Configuration files: .CFG, .TRG
- Data files: .AP, .IQ, .APT, .IQT

2. *Assemble equipment and locate module to be removed:*

- a. You will need a screwdriver with a size Phillips #2 tip (Items 1 and 3) and a No.2 Pozidrive tip (Item 4).
- b. Locate the hard disk drive in the *Inner-Chassis Modules* diagram, Figure 6–3, page 6–14.

3. *Orient the analyzer:* Set the analyzer so its bottom is down on the work surface and its left side is facing you.

4. *Remove the brackets with the hard disk drive:* See Figure 6–12.

- a. Unplug the cables from the CPU board and the A71 DC Power-2 board.
- b. Remove the four screws securing the bracket to the main chassis using a screwdriver with a size Phillips #2 tip.
- c. Lift up the brackets with the hard disk drive.

5. *Remove the hard disk drive:*

- a. Remove the four screws securing the top bracket to the main bracket using a screwdriver with a size Phillips #2 tip.
- b. Remove the four screws securing the hard disk drive to the main bracket using a screwdriver with a size No.2 Pozidrive tip.

6. *Reinstallation:* Reinstall the hard disk drive by performing step 4 and step 5 in reverse.

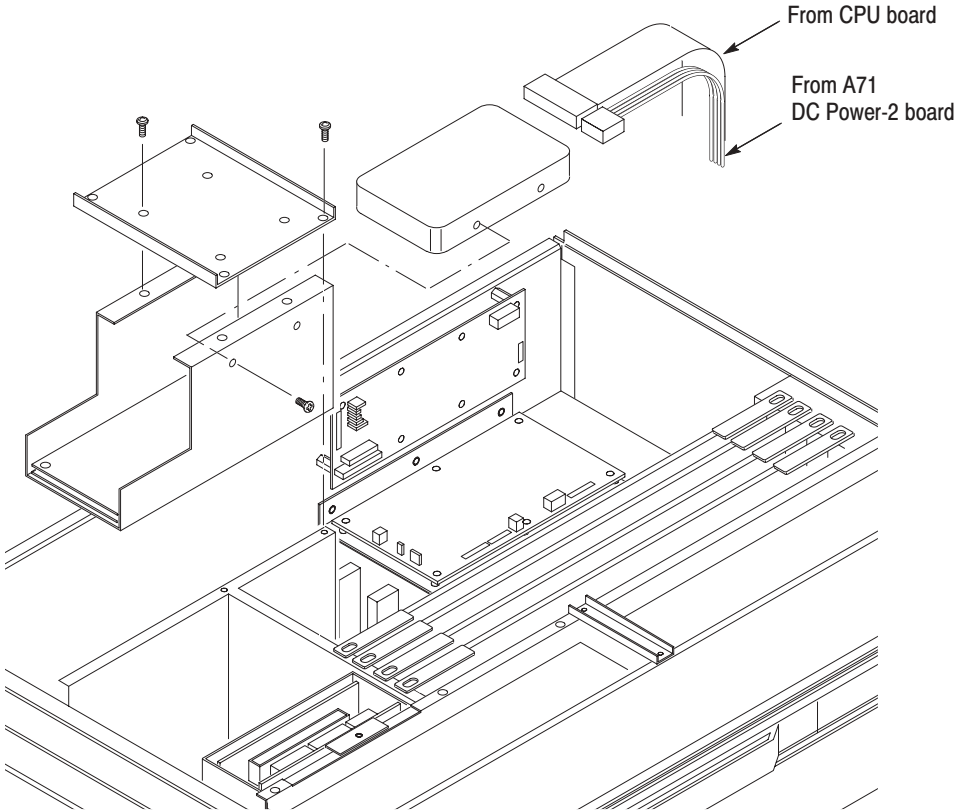


Figure 6-12: Hard disk drive removal

Floppy Disk Drive

- 1.** *Assemble equipment and locate module to be removed:*
 - a.** You will need a screwdriver with size Phillips #1 and #2 tips (Items 1, 2, and 3).
 - b.** Locate the floppy disk drive in the *Inner-Chassis Modules* diagram, Figure 6-3, page 6-14.
- 2.** *Orient the analyzer:* Position the analyzer so its bottom is down on the work surface and its left side is facing you.
- 3.** *Remove the floppy disk drive:* See Figure 6-13.
 - a.** Pulling up the latch, unplug the floppy driver connector (ribbon interconnect cable) that connects the disk drive to the A71 DC Power-2 board.
 - b.** Remove the four screws securing the bracket to the main chassis. Pull the floppy disk drive out from the front-panel assembly.
 - c.** Using a screwdriver with size Phillips #1 tip, remove the four screws securing the floppy disk drive to the bracket.
- 4.** *Reinstallation:* Reinstall the floppy disk drive by performing step 3 in reverse.

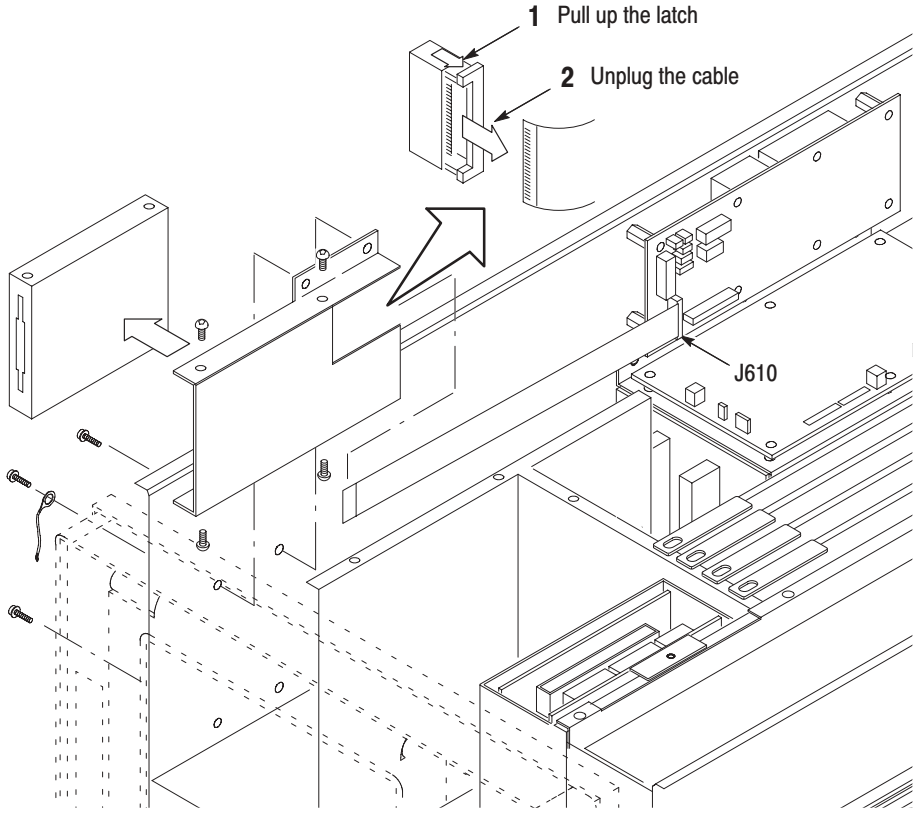


Figure 6-13: Floppy disk drive removal

**A12 IF Gain Board and
A13 IF A/D Board**

1. *Assemble equipment and locate module to be removed:*
 - a. You will need a screwdriver with a size Phillips #2 tip (Items 1 and 3) and a 5.5 mm nutdriver (Item 8).
 - b. Locate the A12 IF gain and A13 IF A/D boards in the *Inner-Chassis Modules* diagram, Figure 6–3, page 6–14.
 - c. Do the procedure *Inner Fan* on page 6–24 to remove the fan bracket from the main chassis. It is **not** necessary to remove the fan from the bracket.
2. *Orient the analyzer:* Position the analyzer so its bottom is down on the work surface and the front panel is facing you.
3. *Remove the core holder:* See Figure 6–14. Remove the two screws securing the core holder to the shield case so that the interconnect cables are released.
4. *Remove the shield case:* The shield case contains the A12 and A13 boards.
 - a. Unplug the cables at J510, J520, and J530 on the A12 board.
 - b. Unplug the cable at J300 on the A13 board.
 - c. Unplug the coax cables at J150 and J220 on the A13 board.
 - d. Remove the one screw securing the shield case to the main chassis.
 - e. Lift up the boards with the shield case from the A50 Mother board.
5. *Remove the A13 IF A/D board:*
 - a. Remove the six screws securing the shield case to open the case.
 - b. Remove the five screws securing the board to the post spacers. Lift the board away.
6. *Remove the A12 IF gain board:* Using a 5.5 mm nutdriver, remove the five post spacers securing the board to the shield case. Lift the board away.
7. *Reinstallation:* Reinstall the A12 IF gain board and A13 IF A/D board by performing step 3 through 6 in reverse.

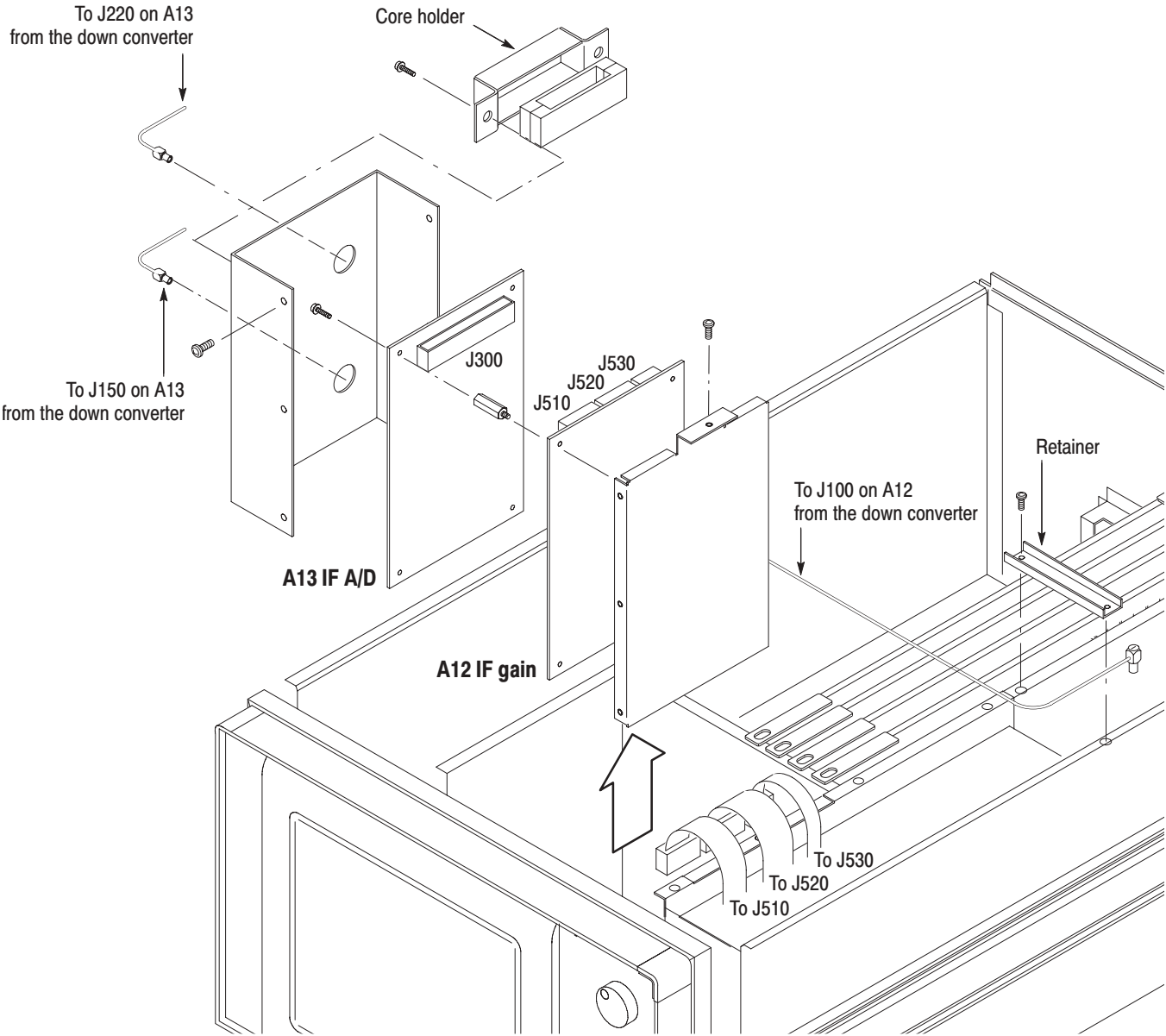


Figure 6-14: A12 IF gain and A13 IF A/D boards removal

**Down Converter
Unit 1**

1. *Assemble equipment and locate module to be removed:*
 - a. You will need a screwdriver with a size Phillips #2 tip (Items 1 and 3) and a $\frac{5}{16}$ inch wrench (Item 12).
 - b. Locate the down converter unit 1 in the *Inner-Chassis Modules* diagram, Figure 6–3, page 6–14.
 - c. Do the procedure *Inner Fan* on page 6–24 to remove the fan bracket from the main chassis. It is **not** necessary to remove the fan from the bracket.
2. *Orient the analyzer:* Set the analyzer so its bottom is down on the work surface and its right side is facing you.
3. *Remove the retainer:* See Figure 6–15. Remove the two screws securing the retainer to the main chassis. Lift the retainer away.
4. *Remove the down converter:* See Figure 6–15.
 - a. Move away the temperature sensor.
 - b. Unplug the cables at CN9, CN13, and CN15.
 - c. Unplug the cable W024.
 - d. Using a $\frac{5}{16}$ inch wrench, disconnect the W13, W16, W30, and W203 SMA connectors.
 - e. Unplug the coax cable W12, W17, W26, W29, W33, and W35.
 - f. Unplug the following coax cables:
 - To 10 MHz REF OUTPUT on the rear panel
 - To 10 MHz REF INPUT on the rear panel
 - g. Unplug the coax cable at J900 on the A20 DDC board.
 - h. Remove the four screws securing the top of the down converter bracket to the main chassis. One of the screws also secures the cable clamp.
 - i. Remove the two screws securing the down-converter bracket to the right side of the main chassis.
 - j. Remove the five screws securing the down converter to the main chassis inside the holes on the right side. Lift the down converter with its bracket away.
5. *Reinstallation:* Reinstall the down converter, the retainer, and the fan bracket by performing the reverse of the removal procedure.

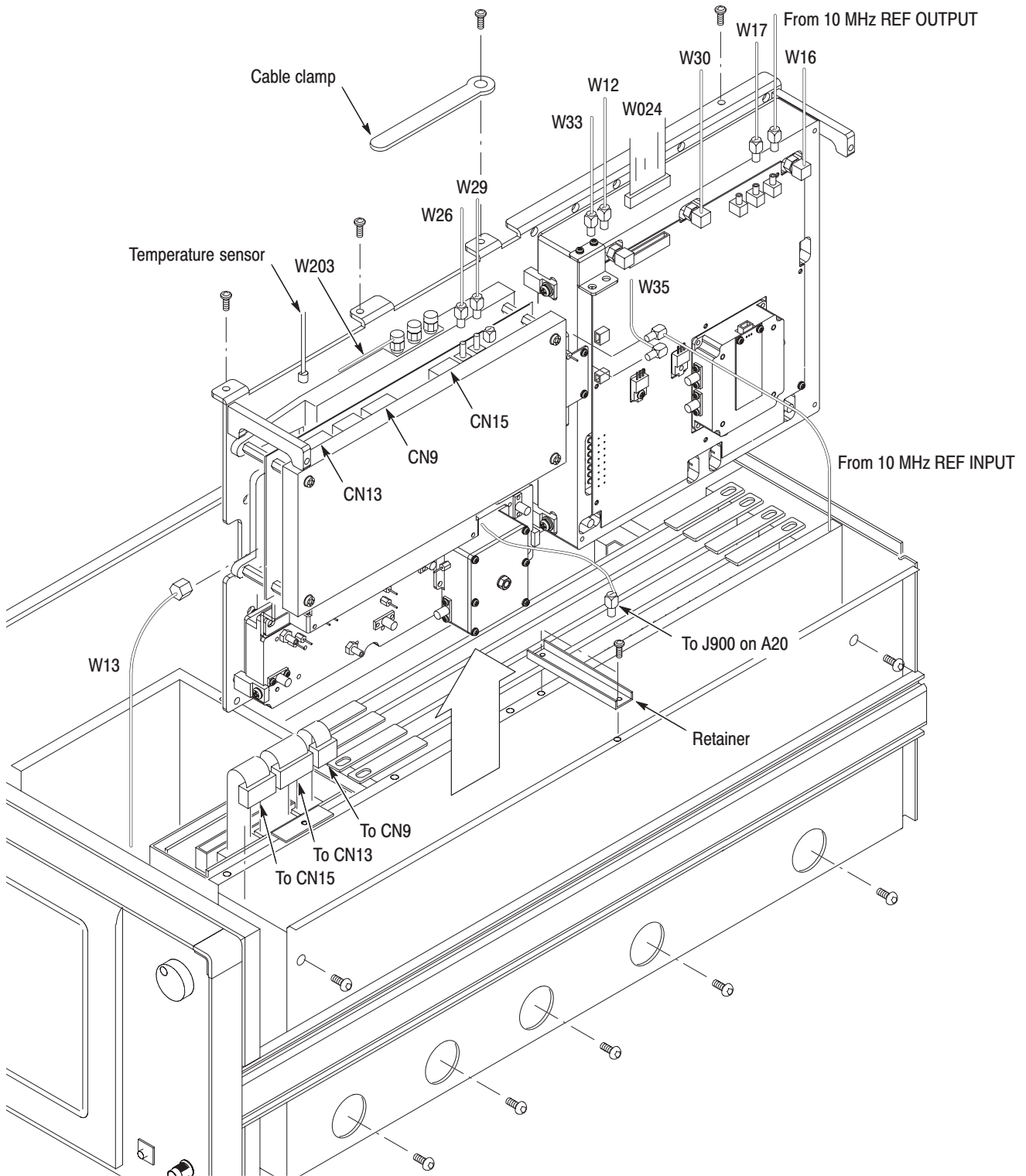


Figure 6-15: Down-converter unit 1 removal

**Down Converter
Unit 2**

1. *Assemble equipment and locate module to be removed:*
 - a. You will need a screwdriver with a size Phillips #2 tip (Items 1 and 3) and a $\frac{5}{16}$ inch wrench (Item 12).
 - b. Locate the down converter unit 2 in the *Inner-Chassis Modules* diagram, Figure 6-3, page 6-14.
2. *Orient the analyzer:* Position the analyzer so its top is down on the work surface and its left side is facing you.
3. *Remove the down converter:* See Figure 6-16.
 - a. Unplug the cable W043 at J950 on the A50 Mother board.
 - b. Using a $\frac{5}{16}$ inch wrench, disconnect the W10, W12, W13, W16, and W203 (WCA380 only) SMA connectors.
 - c. Unplug the SMB cable W17, W27, and W34.
 - d. Remove the nine screws securing the down converter to the main chassis. Lift the down converter away.
4. *Reinstallation:* Reinstall the down converter by performing step 3 in reverse.

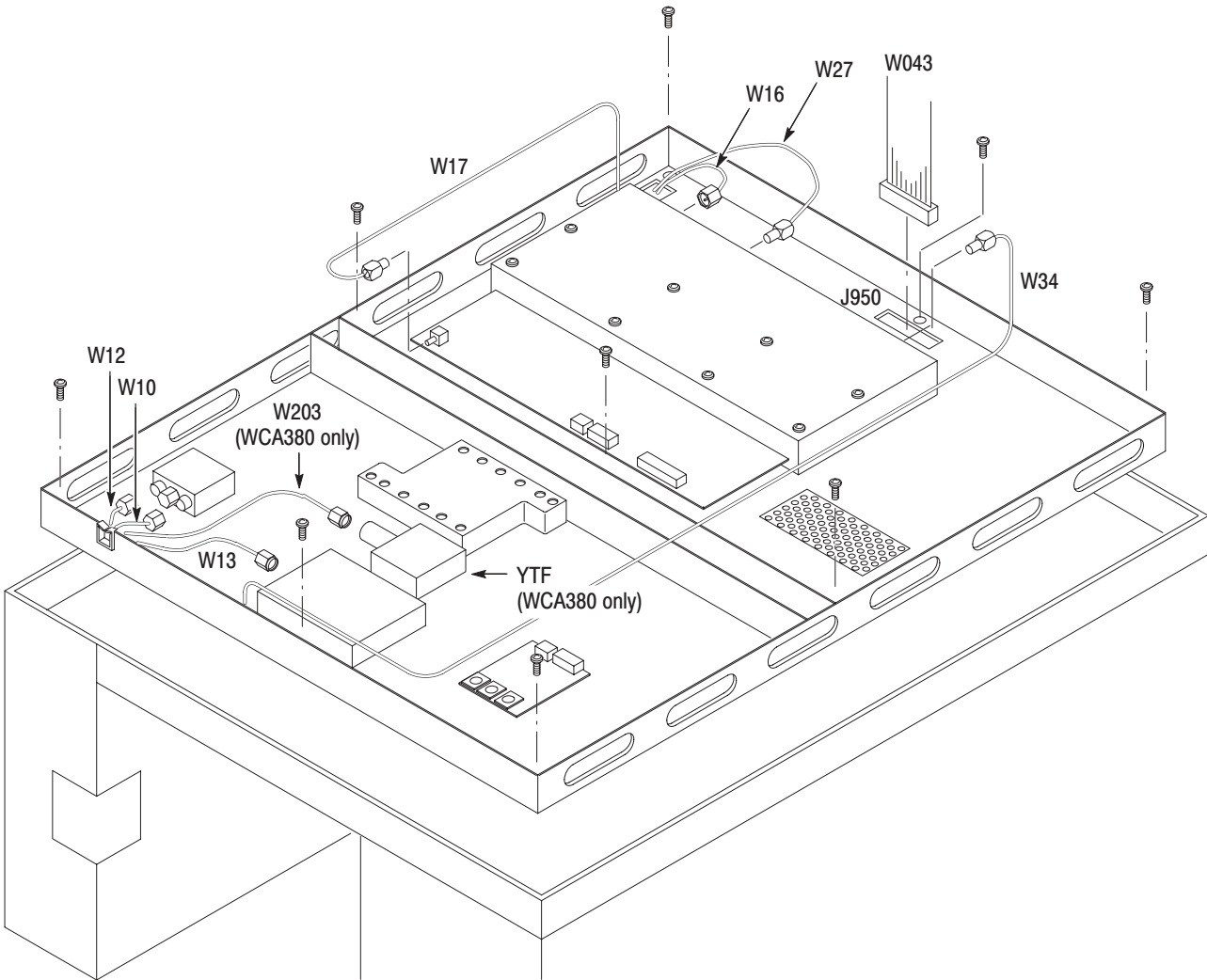


Figure 6-16: Down-converter unit 2 removal (bottom view)

Procedures for Power Supply Modules

You should have completed the *Access Procedure* before doing any procedure in this collection. The procedures found here, listed in order presented, follow.

- *A72 DC power-3 board*
- *Standby power supply*
- *AC line filter*
- *Heat sink*
- *A71 DC power-2 board*
- *A70 DC power-1 board*
- *Power supply*

A72 DC Power-3 Board

1. *Assemble equipment and locate module to be removed:*
 - a. You will need a screwdriver with a size Phillips #2 tip (Items 1 and 3).
 - b. Locate the A72 DC Power-3 board in the locator diagram *Power supply modules*, Figure 6-4, page 6-15.
2. *Orient the analyzer:* Set the analyzer so its bottom is down on the work surface and its left side is facing you.
3. *Remove the brackets:* See Figure 6-12.
 - a. Unplug the cables from the hard disk drive. Refer to the *Hard Disk Drive* procedure on page 6-26. It is **not** necessary to remove the hard disk drive.
 - b. Unplug the cables at J100, J110, J120, J130, J140, J200, J210, J220, and J230 on the A72 DC Power-3 board.
 - c. Remove the four screws securing the brackets to the main chassis. Lift the brackets attaching the hard disk drive and the A72 board.
4. *Remove the A72 DC Power-3 board:*
 - a. Remove the four screws securing the board plate to the bracket.
 - b. Remove the six screws securing the A72 board to the board plate.
5. *Reinstallation:* Reinstall the A72 DC Power-3 board by performing step 3 and step 4 in reverse.

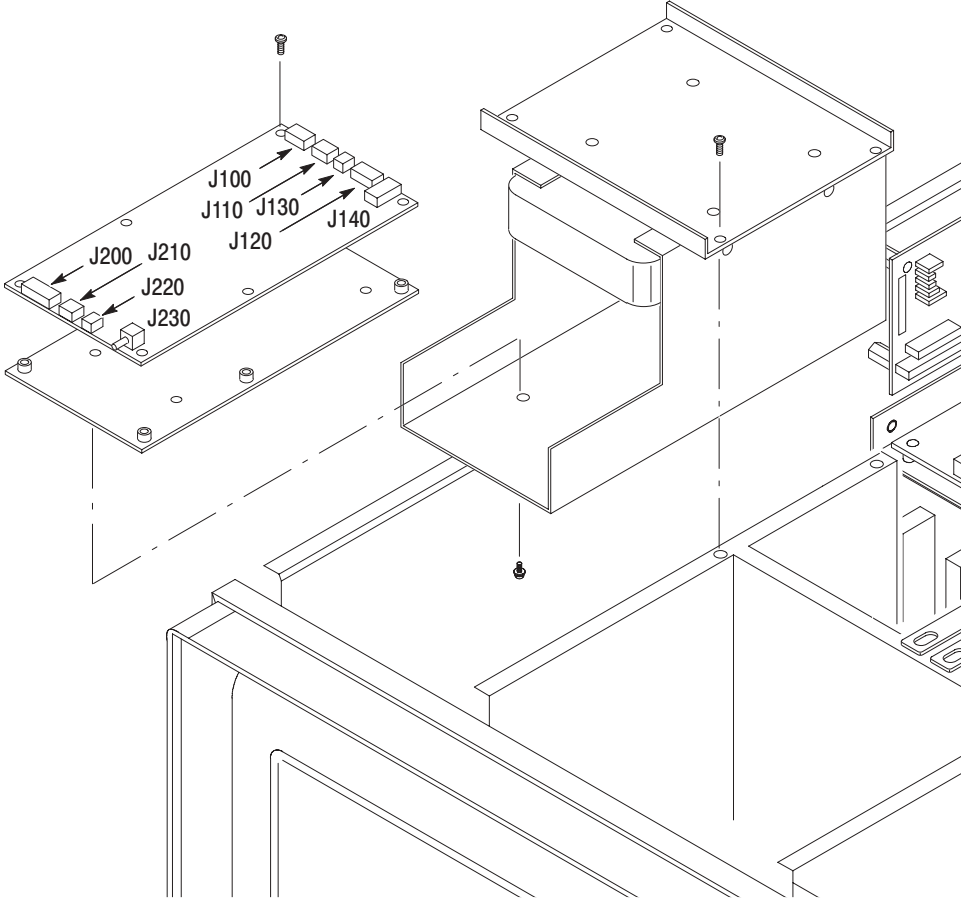


Figure 6-17: A72 DC Power-3 board removal

Standby Power Supply

1. *Assemble equipment and locate module to be removed:*
 - a. You will need a screwdriver with a size Phillips #2 tip (Items 1 and 3).
 - b. Locate the standby power supply in the *Power supply modules* diagram, Figure 6-4, page 6-15.
 - c. Do the procedure *A72 DC Power-3 Board* on page 6-36 to remove the brackets containing the hard disk drive and the A72 DC Power-3 board from the main chassis.
2. *Orient the analyzer:* Set the analyzer so its bottom is down on the work surface and its left side is facing you.
3. *Remove the standby power supply:* See Figure 6-18.
 - a. Unplug the cables W047 and W048.
 - b. Remove the two screws securing the standby power supply to the main chassis. Lift the standby power supply away from the main chassis.
4. *Reinstallation:* Reinstall the standby power supply by performing step 3 in reverse.

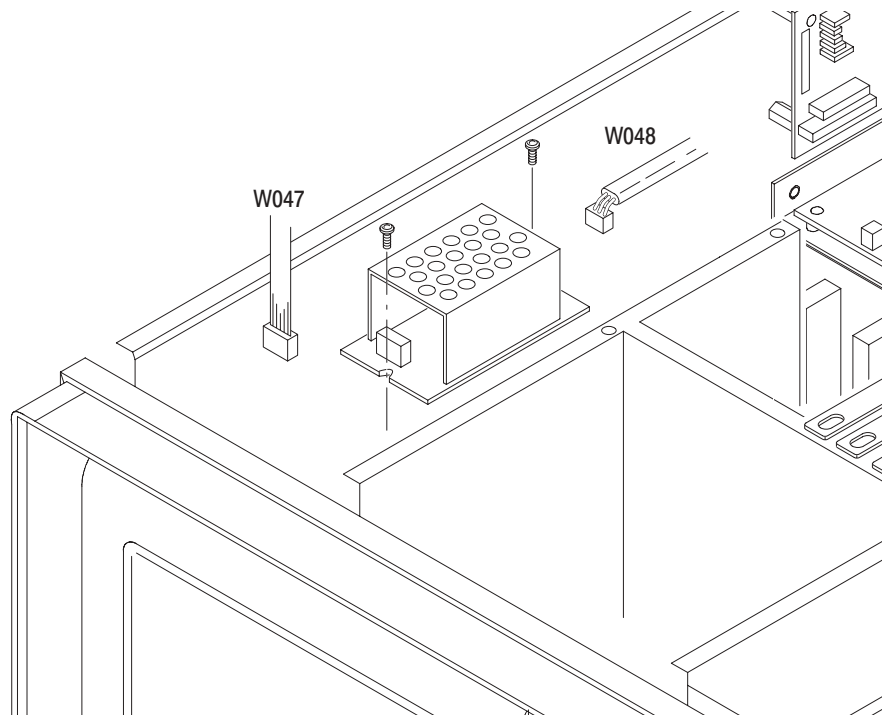
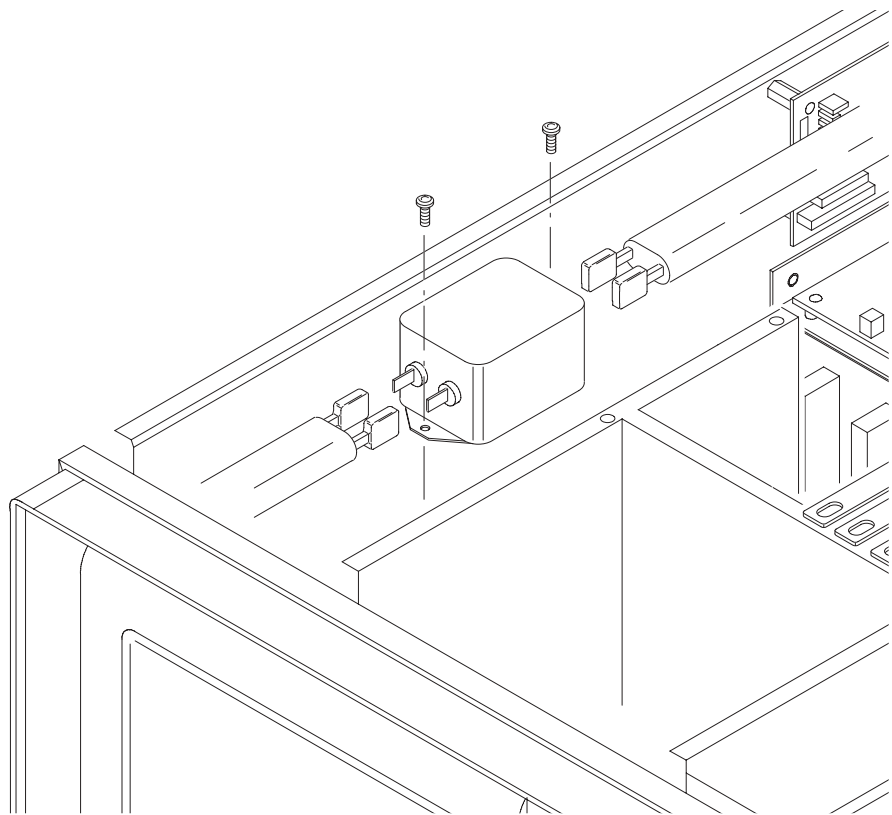


Figure 6-18: Standby power supply removal

AC Line Filter

1. *Assemble equipment and locate module to be removed:*
 - a. You will need a screwdriver with a size Phillips #2 tip (Items 1 and 3).
 - b. Locate the AC line filter in the *Power supply modules* diagram, Figure 6-4, page 6-15.
2. *Orient the analyzer:* Set the analyzer so its bottom is down on the work surface and its left side is facing you.
3. *Remove the board retainer:* See Figure 6-19.
 - a. Unplug the AC cables from the filter.
 - b. Remove the two screws securing the filter to the main chassis. Lift the filter away.
4. *Reinstallation:* Reinstall the AC line filter by performing step 3 in reverse.

**Figure 6-19: AC line filter removal**

Heat Sink

1. *Assemble equipment and locate module to be removed:*
 - a. You will need a screwdriver with a size Phillips #2 tip (Items 1 and 3).
 - b. Locate the heat sink in the *Power supply modules* diagram, Figure 6-4, page 6-15.
2. *Orient the analyzer:* Position the analyzer so its bottom is down on the work surface and its left side is facing you.
3. *Remove the heat sink:* See Figure 6-20. Remove the eight screws securing the heat sink to the main chassis.
4. *Reinstallation:* Reinstall the heat sink by performing step 3 in reverse

A71 DC Power-2 Board

1. *Assemble equipment and locate module to be removed:*
 - a. You will need a screwdriver with a size Phillips #2 tip (Items 1 and 3).
 - b. Locate the A71 DC power-2 board in the *Power supply modules* diagram, Figure 6-4, page 6-15.
2. *Orient the analyzer:* Position the analyzer so that the bottom of the instrument is down on the work surface and the front panel is facing you.
3. *Remove the A71 DC power-2 board:* See Figure 6-20.
 - a. Unplug the cables at J500, J510, J520, J530, J531, J532, J540, J541, J600, and J610 on the A71 board.
 - b. Remove the four screws securing the board to the main chassis.

NOTE. Do not remove the inner four screws securing the DC-DC converter.

- c. Use a flat blade screwdriver (Item 5) to separate the DC-DC converter from the main chassis. The DC-DC converter sticks to the main chassis with silicon grease.
4. *Reinstallation:* Reinstall the A71 DC power-2 board by performing step 3 in reverse.

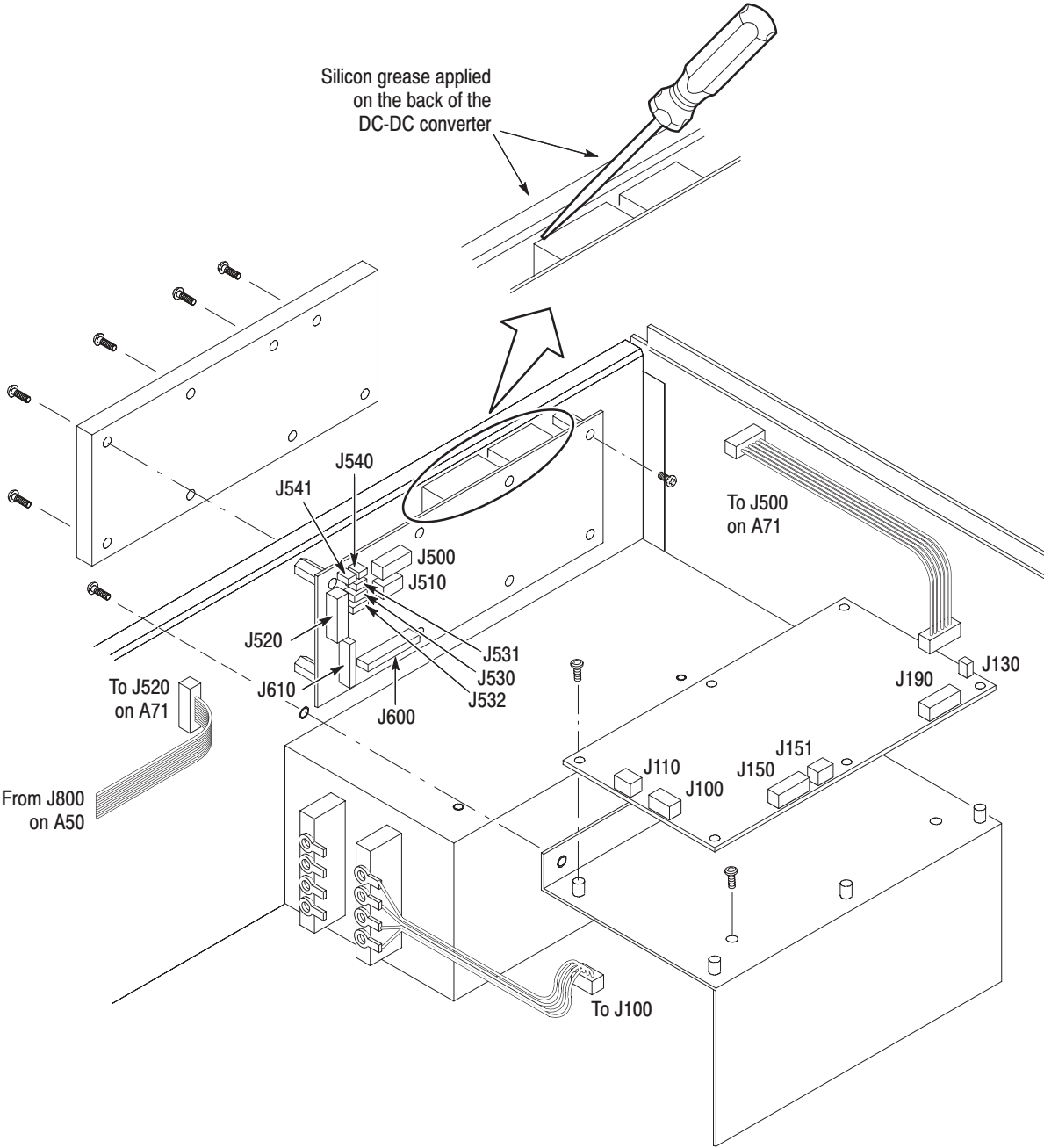


Figure 6-20: Power supply modules removal

A70 DC Power-1 Board

1. *Assemble equipment and locate module to be removed:*
 - a. You will need a screwdriver with a size Phillips #2 tip (Items 1 and 3).
 - b. Locate the A70 DC power-1 board in the *Power supply modules* diagram, Figure 6-4, page 6-15.
2. *Orient the analyzer:* Set the analyzer so its bottom is down on the work surface and its right side is facing you.
3. *Remove the A70 DC power-1 board:* See Figure 6-20.
 - a. Unplug the cables at J100, J110, J130, J150, J151, and J190 on the A70 board.
 - b. Remove the six screws securing the board to the shield plate. Lift the board away.
4. *Reinstallation:* Reinstall the A70 DC power-1 board by performing step 3 in reverse.

Power Supply

1. *Assemble equipment and locate module to be removed:*
 - a. You will need a screwdriver with a size Phillips #2 tip (Items 1 and 3).
 - b. Locate the power supply in the *Power supply modules* diagram, Figure 6-4, page 6-15.
 - c. Do the procedure *A70 DC Power-1 Board* that precedes this procedure to remove the board.
2. *Orient the analyzer:* Position the analyzer so the bottom of the instrument is down on the work surface and the left side is facing you.
3. *Remove the board bracket:* See Figure 6-20.
 - a. Remove the three screws securing the bracket to the main chassis.
 - b. Remove the six screws securing the bracket to the power supply. Lift the bracket away.
4. *Remove the bottom cabinet:* Refer to page 6-21 to remove the bottom cabinet.
5. *Orient the analyzer:* Position the analyzer so its left side is down on the work surface and the bottom of the instrument is facing you.
6. *Remove the power supply:* See Figure 6-21. Remove the four screws securing the power supply unit to the main chassis. Lift the unit away to complete the removal.

7. *Reinstallation:* Reinstall the power supply unit, and the A70 DC power-1 board by performing the reverse of the removal procedure.

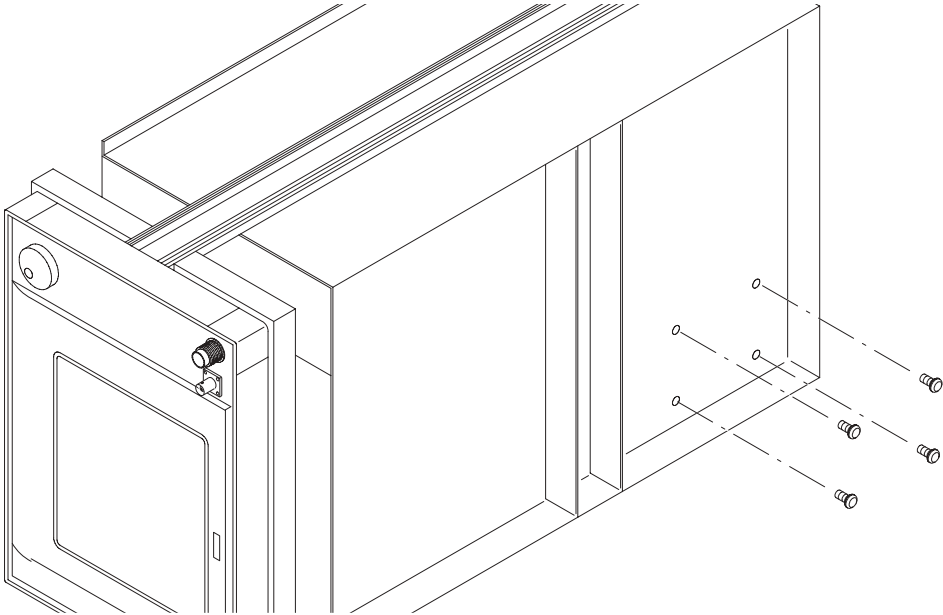


Figure 6-21: Power supply unit removal

Procedures for Mother Board and its Daughter Boards

You should have completed the *Access Procedure* before doing any procedure in this collection. The procedures found here, listed in order presented, follow.

- *Video board*
- *CPU board*
- *GPIB board*
- *A40 memory board*
- *A30 FFT board*
- *A22 Wide ADC board*
- *A20 DDC board*
- *A50 Mother board*

Video Board

1. *Assemble equipment and locate module to be removed:*
 - a. You will need a screwdriver with size Phillips #1 and #2 tips (Items 1, 2, and 3).
 - b. Locate the Video board in locator diagram *Mother board and its daughter boards*, Figure 6–5, page 6–16.
2. *Orient the analyzer:* Position the analyzer so the bottom of the instrument is down on the work surface and the right side is facing you.
3. *Remove the bracket:* See Figure 6–22. Three retainers are attached to the bracket.
 - a. Unplug the display cable.
 - b. Remove the two screws securing the CPU board retainer to the main chassis.
 - c. Remove the one screw securing the bracket to the main chassis. Lift up the bracket with the video board.
4. *Remove the Video board:*
 - a. Using a screwdriver with a size Phillips #1 tip, remove the forward screw securing the board to the bracket.
 - b. Using a screwdriver with a size Phillips #2 tip, remove the backward screw securing the board to the bracket.
5. *Reinstallation:* Reinstall the Video board by reversing steps 3 and 4.

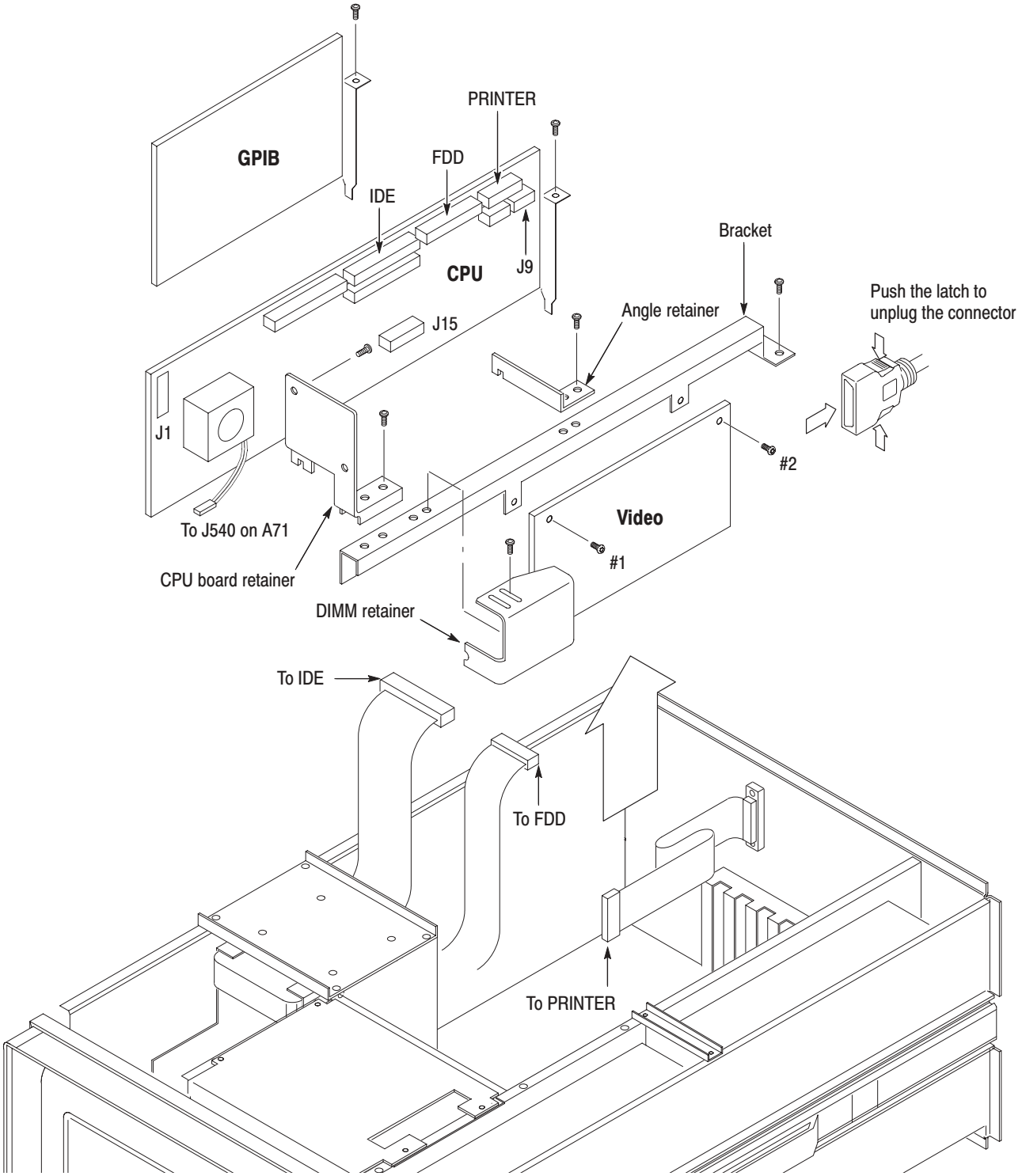


Figure 6-22: CPU, GPIB, and Video boards removal

CPU Board

1. *Assemble equipment and locate module to be removed:*
 - a. You will need a screwdriver with a size Phillips #2 tip (Items 1 and 3).
 - b. Locate the CPU board in the *Mother board and its daughter boards* diagram, Figure 6–5, page 6–16.
 - c. Do the procedure *Video Board* on page 6–44 to remove the CPU board retainer, angle retainer, and DIMM retainer (see Figure 6–22).
2. *Orient the analyzer:* Set the analyzer so its bottom is down on the work surface and its right side is facing you.
3. *Remove the CPU board:*
 - a. Unplug the cables at FDI, IDE, and PRINTER ports on the CPU board.
 - b. Unplug the cables at J1, J9, and J15 on the CPU board.
 - c. Unplug the fan cable at J540 on the A71 DC Power-2 board.
 - d. Remove the one screw securing the board to the main chassis. Lift the board up away.
4. *Reinstallation:* Reinstall the CPU board using the reverse of step 3.

GPIB Board

1. *Assemble equipment and locate module to be removed:*
 - a. You will need a screwdriver with a size Phillips #2 tip (Items 1 and 3).
 - b. Locate the GPIB board in the *Mother board and its daughter boards* diagram, Figure 6–5, page 6–16.
2. *Orient the analyzer:* Set the analyzer so its bottom is down on the work surface and its right side is facing you.
3. *Remove the GPIB board:* See Figure 6–22. Remove the one screw securing the board to the main chassis. Lift the board up away.
4. *Reinstallation:* Reinstall the GPIB board using the reverse of step 3.

A40 Memory Board

1. *Assemble equipment and locate module to be removed:*
 - a. You will need a screwdriver with a size Phillips #2 tip (Items 1 and 3).
 - b. Locate the A40 Memory board in the *Mother board and its daughter boards* diagram, Figure 6-5, page 6-16.
2. *Orient the analyzer:* Set the analyzer so its bottom is down on the work surface and its right side is facing you.
3. *Remove the A40 Memory board:* See Figure 6-23.
 - a. Unplug the coaxial cable at J640.
 - b. Unplug the cable at J650.
 - c. Remove the two screws securing the board to the main chassis. Lift the board up away from the Mother board.
4. *Reinstallation:* Reinstall the A40 Memory board using the reverse of step 3.

A30 FFT Board

1. *Assemble equipment and locate module to be removed:*
 - a. You will need a screwdriver with a size Phillips #2 tip (Items 1 and 3).
 - b. Locate the A30 FFT board in the *Mother board and its daughter boards* diagram, Figure 6-5, page 6-16.
 - c. Referring to the procedure *A40 Memory Board* described just above, remove the interconnect cable W044.
2. *Orient the analyzer:* Set the analyzer so its bottom is down on the work surface and its right side is facing you.
3. *Remove the A30 FFT board:* See Figure 6-23. Remove the two screws securing the board to the main chassis. Lift the board up away from the Mother board.
4. *Reinstallation:* Reinstall the A30 FFT board and interconnect cable using the reverse of the removal procedure.

A22 Wide ADC Board

1. *Assemble equipment and locate module to be removed:*
 - a. Have handy a screwdriver with a size Phillips #2 tip (Items 1 and 3).
 - b. Locate the A22 Wide ADC board in the *Mother board and its daughter boards* diagram, Figure 6-5, page 6-16.
2. *Orient the analyzer:* Set the analyzer so its bottom is down on the work surface and its right side is facing you.
3. *Remove the A22 Wide ADC board:* See Figure 6-23.
 - a. Unplug the coaxial cables at J100, J110, J170, J180, and J190.
 - b. Unplug the cables at J730 and J810.
 - c. Remove the two screws securing the board to the main chassis. Lift the board up away from the Mother board.
4. *Reinstallation:* Reinstall the A22 DDC board using the reverse of step 3.

A20 DDC Board

1. *Assemble equipment and locate module to be removed:*
 - a. You will need a screwdriver with a size Phillips #2 tip (Items 1 and 3).
 - b. Locate the A20 DDC board in the *Mother board and its daughter boards* diagram, Figure 6-5, page 6-16.
2. *Orient the analyzer:* Set the analyzer so its bottom is down on the work surface and its right side is facing you.
3. *Remove the A20 DDC board:* See Figure 6-23.
 - a. Unplug the coaxial cables at J900, J910, and J920.
 - b. Unplug the cable at J140.
 - c. Remove the two screws securing the board to the main chassis. Lift the board up away from the Mother board.
4. *Reinstallation:* Reinstall the A20 DDC board and interconnect cables using the reverse of the removal procedure.

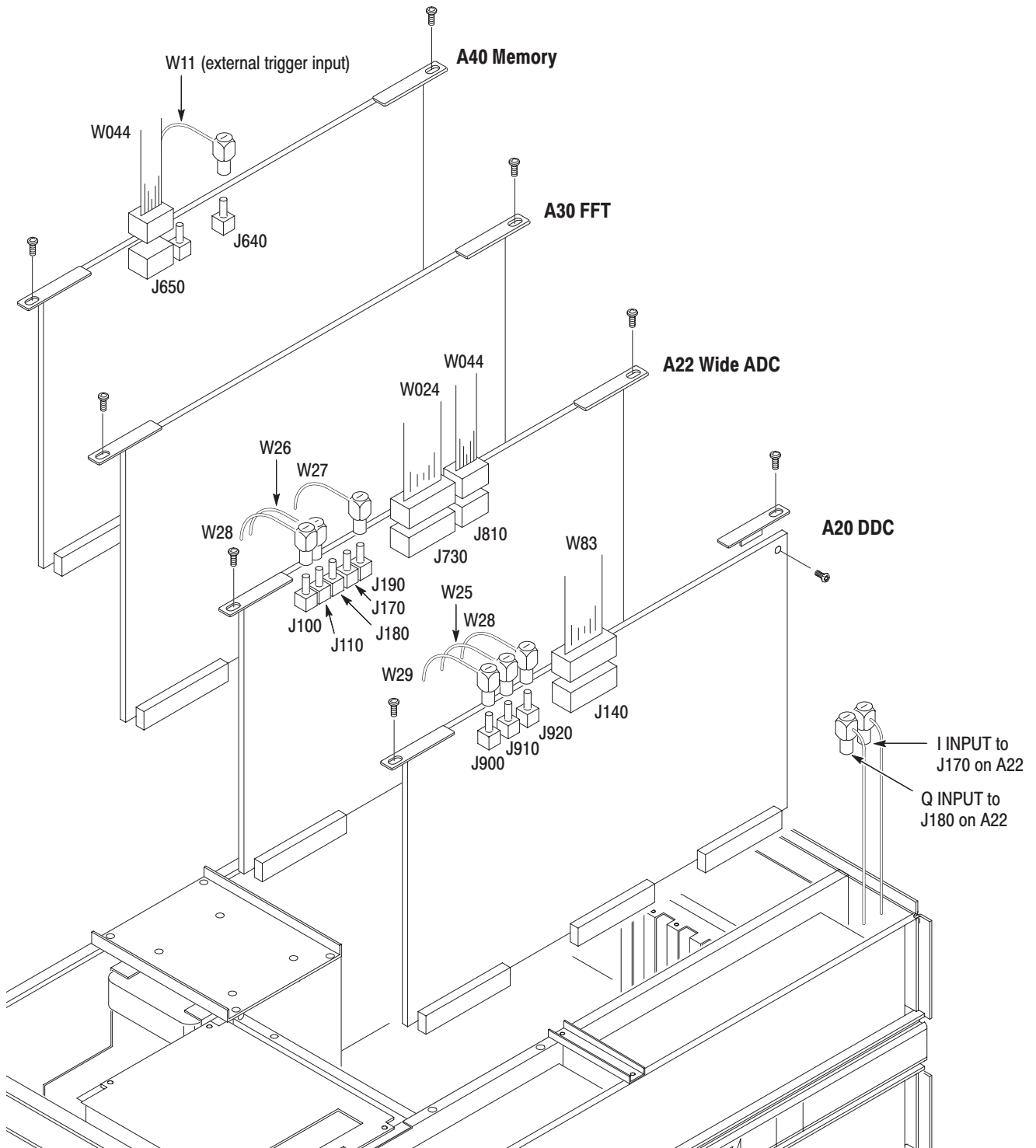


Figure 6-23: A20 DDC, A22 Wide ADC, A30 FFT, and A40 Memory boards removal

A50 Mother Board

1. *Assemble equipment and locate module to be removed:*
 - a. Have handy a screwdriver with a size Phillips #2 tip (Items 1 and 3).
 - b. Locate the Mother board in the *Mother board and its daughter boards* diagram, Figure 6-5, page 6-16.
 - c. Do the procedure *Inner Fan* on page 6-24 to remove the fan bracket from the main chassis. It is **not** necessary to remove the fan from the bracket.
 - d. Do the procedure *GPIB Board through A20 DDC Board* starting on page 6-46 to remove these daughter boards.
 - e. Do the procedure *Front Panel Assembly* on page 6-52 to remove the front panel assembly.
 - f. Referring to the procedure *Down Converter Unit 2* on page 6-34, unplug the interconnect cable at J950 on the Mother board.
2. *Orient the analyzer:* Set the analyzer so its bottom is down on the work surface and its right side is facing you.
3. *Remove the Mother board:*
 - a. Unplug the temperature sensor at J880 on the Mother board.
 - b. Unplug the cables at J800, J810, J820, J830, J870, and J900 on the Mother board.
 - c. Remove 16 screws securing the board to the main chassis. Pull forward the board out.
4. *Reinstallation:*
 - a. Reinstall the Mother board using the reverse of step 3.
 - b. Reconnect the interconnect cable at J950 on the Mother board. Refer to the procedure *Down Converter Unit 2*.
 - c. Reinstall the front panel assembly. Refer to the procedure *Front Panel Assembly*.
 - d. Reinstall the daughter boards. Refer to the procedure *GPIB Board through A20 DDC Board*.

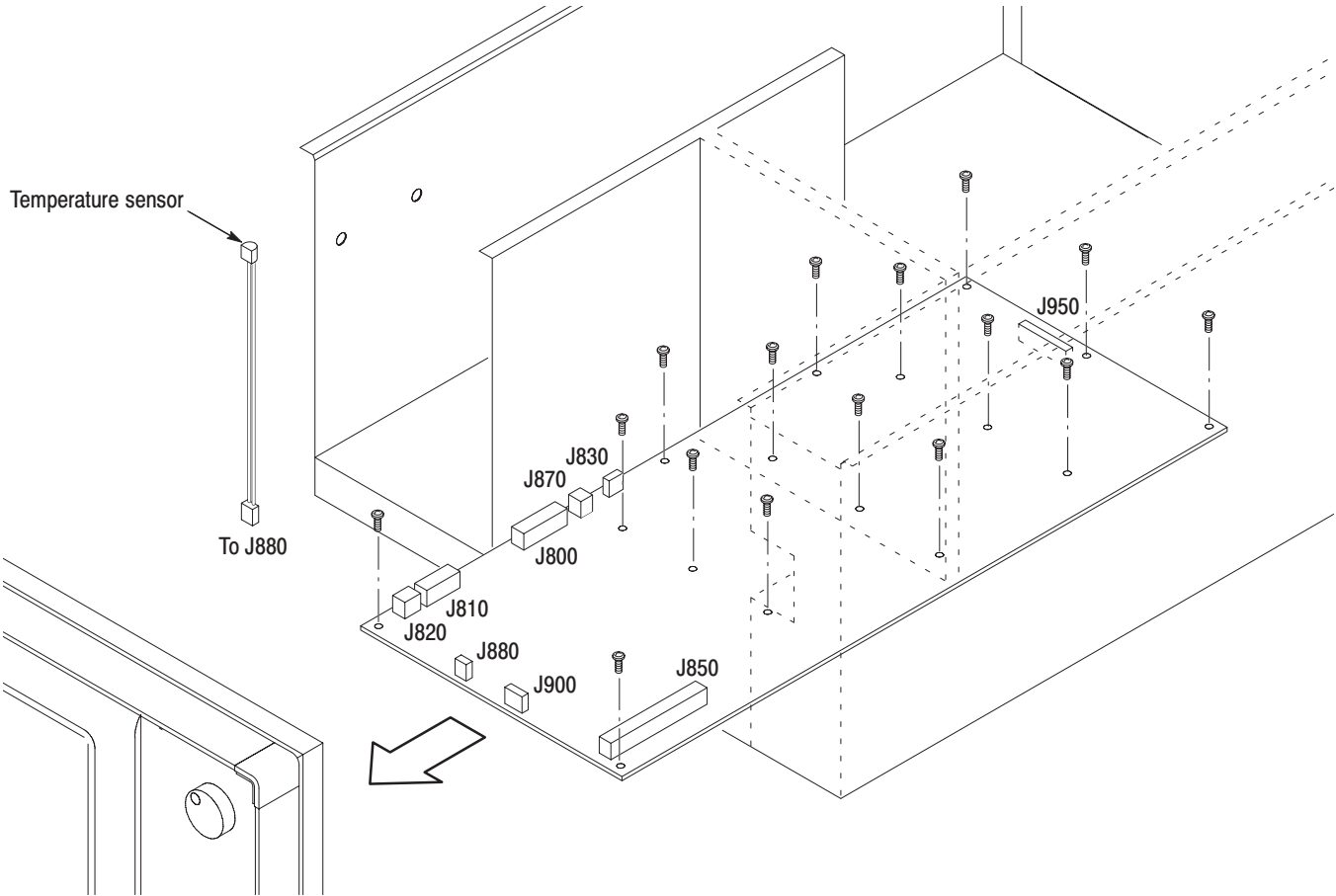


Figure 6-24: Mother board removal

Procedures for Front Panel Modules

Do the *Access Procedure* (page 6–19) before doing any procedure in this collection. The following procedures are found here and are listed in order presented.

- *Front panel assembly*
- *Display unit*
- *Left front panel assembly*
- *Right front panel assembly*

Front Panel Assembly

1. *Assemble equipment and locate module to be removed:*
 - a. Have handy a screwdriver with a size Phillips #2 tip (Items 1 and 3) and a $\frac{5}{16}$ inch wrench (Item 12).
 - b. Locate the front panel assembly in the locator diagram *Front panel modules*, Figure 6–6, page 6–17.
 - c. Do the procedure *Inner Fan* on page 6–24 to remove the fan bracket from the main chassis. It is **not** necessary to remove the fan from the bracket.
 - d. Do the procedure *Hard Disk Drive* on page 6–26 to remove the bracket containing the hard disk drive and A72 DC Power-3 board.
 - e. Do the procedure *Video Board* on page 6–44 to remove the video board.
 - f. Referring to the procedure *Down Converter Unit 2* on page 6–34, disconnect the coax cable W10 from the down converter unit 2 with a $\frac{5}{16}$ inch wrench.
2. *Orient the analyzer:* Set the analyzer so its bottom is down on the work surface and its right side is facing you.
3. *Remove the front-panel assembly:* See Figure 6–25.
 - a. Unplug the cables at the following connectors:
 - J900 on the A50 Mother board
 - J9 on the CPU board
 - J532 on the A71 DC Power-2 board
 - J210 and J220 on the A72 DC Power-3 board
 - b. Unplug the coax cable at J640 on the A40 Memory board.

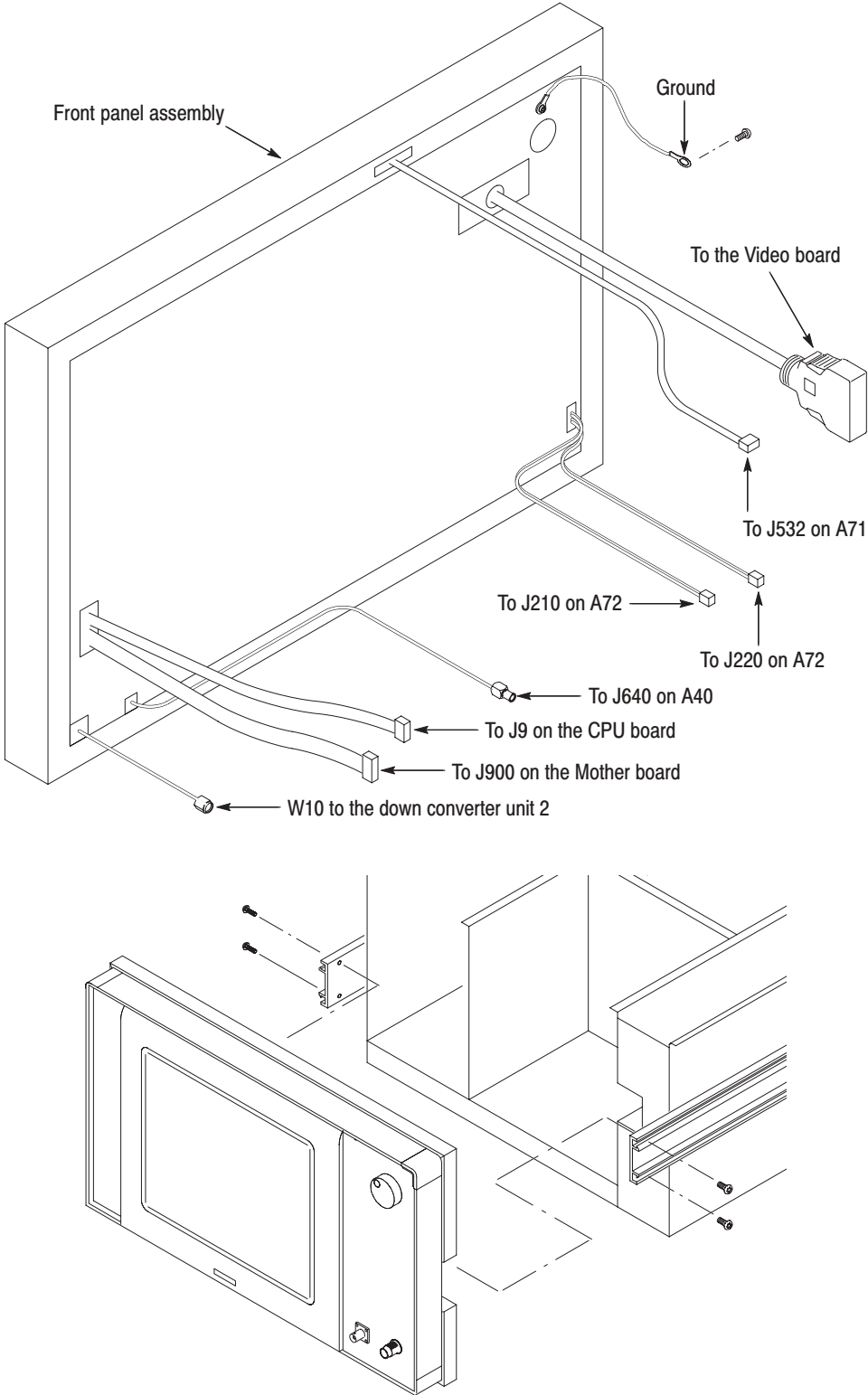


Figure 6-25: Front panel assembly removal

- c. Remove the ground lead.
 - d. Remove the two screws securing the front panel to the rail on each side.
 - e. Pull out the display unit.
4. *Reinstallation:*
- a. Reinstall the front panel assembly by performing step 3 in reverse.
 - b. Reconnect W10 to the down converter unit 2. Refer to the procedure *Down Converter Unit 2* on page 6–34.
 - c. Reinstall the Video Board. Refer to page 6–44.
 - d. Reinstall the bracket containing the hard disk drive and A72 DC Power-3 board. Refer to the procedure *Hard Disk Drive* on page 6–26.
 - e. Reinstall the fan bracket to the main chassis. Refer to the procedure *Inner Fan*.

Display Unit

1. *Assemble equipment and locate module to be removed:*
 - a. You will need a screwdriver with a size Phillips #2 tip (Items 1 and 3).
 - b. Locate the display unit in the *Front panel modules* diagram, Figure 6–6, page 6–17.
2. *Orient the display unit:* Position the front panel assembly so its face is down on the work surface with the back of the unit facing you.
3. *Remove the display unit:* See Figure 6–26.
 - a. Remove the two screws securing the left front-panel to the frame.
 - b. Remove the two screws securing the left front-panel to the front chassis. Lift the left front-panel assembly away.
 - c. Remove the two screws securing the right front-panel to the frame.
 - d. Remove the two screws securing the right front-panel to the front chassis. Lift the right front-panel assembly away.
 - e. Remove the 10 screws securing the frame to the front chassis.
 - f. Remove the two screws securing the shield plate to the front chassis. Lift the shield plate away.
 - g. Lift the front chassis away.
 - h. Remove the four screws securing the display unit to the frame.
 - i. Lift the display unit away.

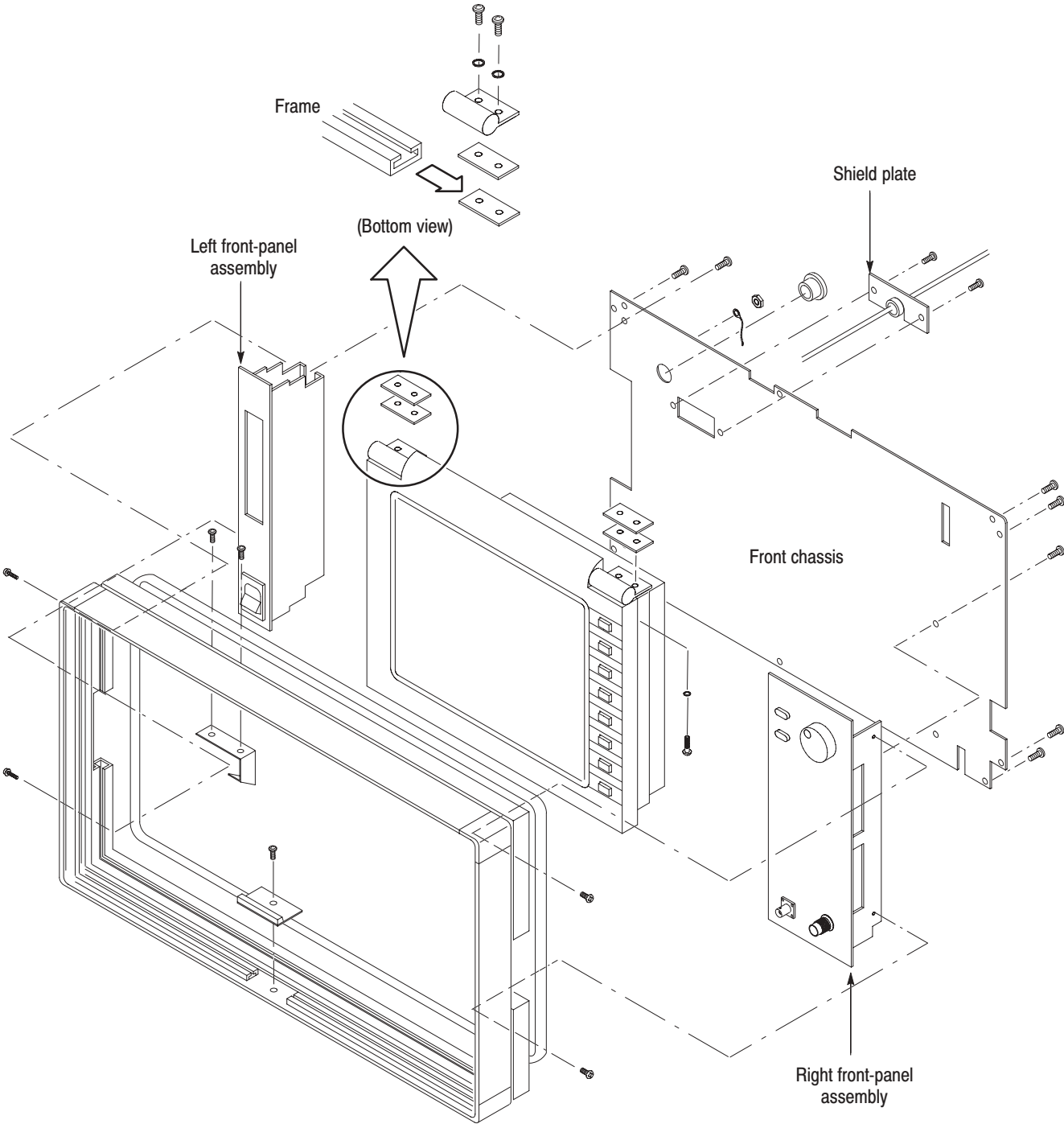


Figure 6-26: Display unit removal

- 4. *Reinstallation:* Reinstall the display unit by performing step 3 in reverse.

Left Front-Panel Assembly

1. *Assemble equipment and locate module to be removed:*
 - a. Have handy a flat-bladed screwdriver (Item 5).
 - b. Locate the left front-panel assembly in the *Front panel modules* diagram, Figure 6-6, page 6-17.
 - c. Do the procedure *Front Panel Assembly and Display Unit* that precede this procedure to detach the left front-panel assembly.
2. *Remove the LED:* See Figure 6-27. Using a flat-bladed screwdriver, pry the LED holder
3. Now hand disassemble the front-panel assembly components using Figure 6-27 as a guide. Reverse procedure to reassemble.

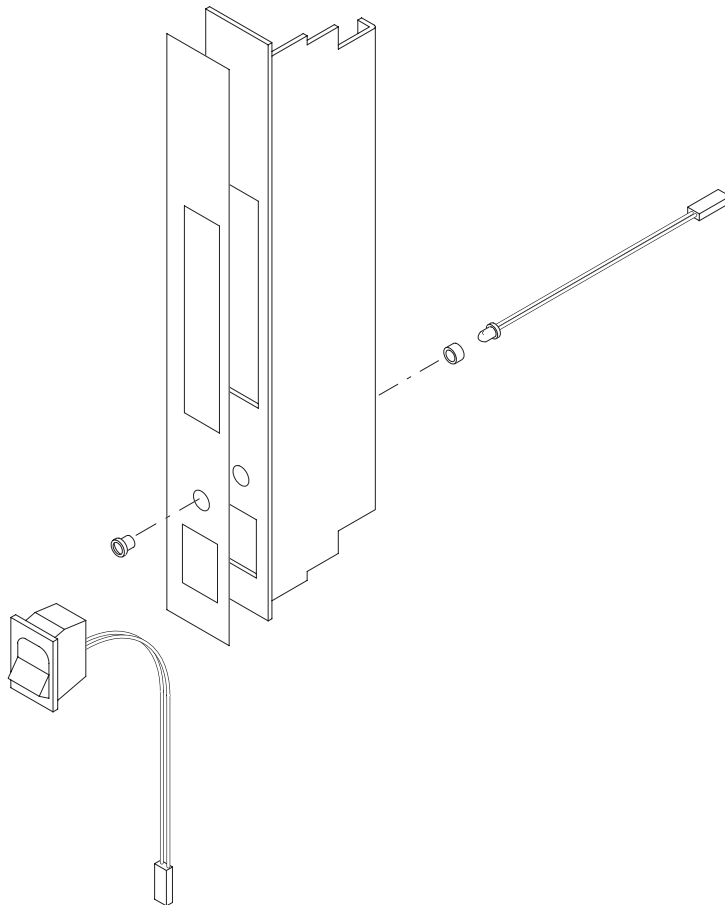


Figure 6-27: Left front-panel assembly removal

4. Reinstallation:

- a. Reinstall the left front-panel assembly by performing step 3 then step 2 in reverse.
- b. Do the procedure *Front Panel Assembly and Display Unit* in reverse to attach the left front-panel assembly to the frame.

Right Front-Panel Assembly**1. Assemble equipment and locate module to be removed:**

- a. Have handy a screwdriver with size Phillips #1 and #2 tips (Items 1, 2, and 3), a $\frac{9}{16}$ inch nut driver (Item 7), 12 mm nut driver (Item 10), and a $\frac{1}{16}$ inch hex wrench (Item 11).
- b. Locate the right front-panel unit in the *Front panel modules* diagram, Figure 6-6, page 6-17.
- c. Do the procedure *Front Panel Assembly and Display Unit* that precede this procedure to detach the right front-panel assembly.

2. Remove the general purpose knob: See Figure 6-28. Loosen the setscrew securing the knob using the $\frac{1}{16}$ inch hex wrench. Pull the knob away.**3. Remove the A60 front panel board:**

- a. Unplug the cables at J135 and J900 on the A60 front panel board.
- b. Remove the six screws securing the board to the subpanel with a size Phillips #2 tip (Items 1 and 3). Lift the board away.

4. Remove the rotary encoder:

- a. Unplug the rotary encoder cable at J400 on the A60 front panel board.
- b. Using the 12 mm nut driver (Item 10), remove the nut securing the rotary encoder to the A60 front panel board.

5. Remove the RF INPUT connector: Unplug the cable. Using the $\frac{9}{16}$ inch nut driver (Item 7), remove the nut securing the connector to the front panel.**6. Remove the EXT TRIG connector:** Unplug the cable. Using the screwdriver with a size Phillips #1 tip (Items 1 and 2), remove the four screws securing the connector to the front panel.**7. Now disassemble the front-panel assembly components using Figure 6-28 as a guide. Reverse the procedure to reassemble.**

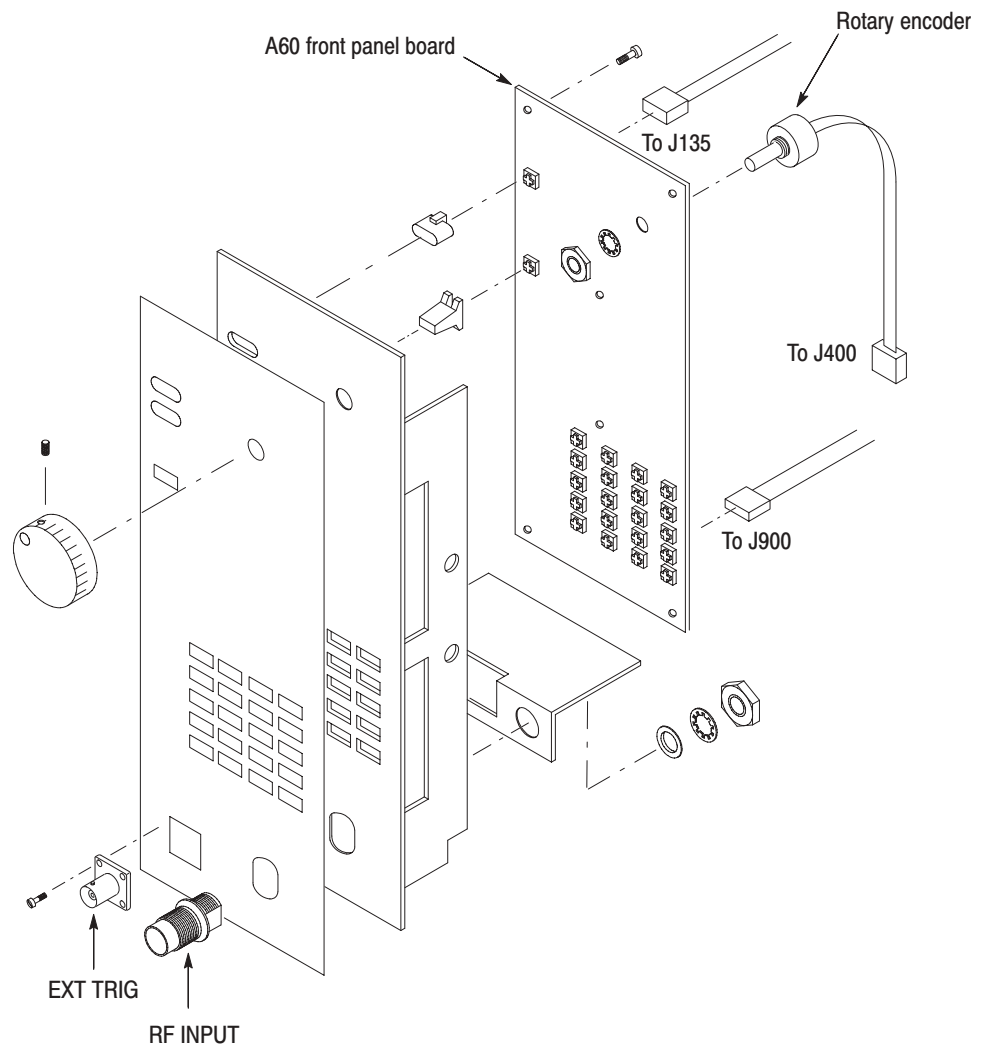


Figure 6-28: Right front-panel assembly removal

8. Reinstallation:

- a. Reinstall the right front-panel assembly by performing step 2 to 7 in reverse.
- b. Do the procedure *Front Panel Assembly and Display Unit* in reverse to attach the right front-panel assembly to the frame.

Procedures for Rear Chassis Modules

Do the *Access Procedure* (page 6–19) before doing any procedure in this collection. The following procedures are listed in the order presented.

- *Fan*
- *Parallel connector*
- *BNC connectors*
- *Receptacle*
- *Principal power switch*

- Fan**
1. *Assemble equipment and locate module to be removed:*
 - a. You will need a screwdriver with a size Phillips #2 tip (Items 1 and 3).
 - b. Locate the fan in the locator diagram *Rear chassis modules*, Figure 6–7, page 6–18.
 2. *Orient the analyzer:* Set the analyzer so its bottom is down on the work surface and its rear is facing you.
 3. *Remove the fan:*
 - a. Unplug the fan's power cable at J541 on the A71 DC Power-2 board.
 - b. Remove the four screws securing the fan to the main chassis. Pull the fan and its cover away.
 4. *Reinstallation:* Reinstall the fan by performing step 3 in reverse.

- Parallel Connector**
1. *Assemble equipment and locate module to be removed:*
 - a. You will need a $\frac{1}{4}$ inch nut driver (Item 6).
 - b. Locate the parallel connector in the *Rear chassis modules* diagram, Figure 6–7, page 6–18.
 2. *Orient the analyzer:* Set the analyzer so its bottom is down on the work surface and its rear is facing you.
 3. *Remove the parallel connector:*
 - a. Unplug the cable from the CPU board.
 - b. Using a $\frac{1}{4}$ inch nut driver, unscrew the two hex-headed mounting posts that secure the connector to the rear chassis. Pull the connector away.

4. *Reinstallation:* Reinstall the parallel connector by performing step 3 in reverse.

BNC Connectors

1. *Assemble equipment and locate module to be removed:*
 - a. You will need a screwdriver with a size Phillips #1 tip (Items 1 and 2).
 - b. Locate the BNC connector in the *Rear chassis modules* diagram, Figure 6–7, page 6–18.
2. *Orient the analyzer:* Set the analyzer so its bottom is down on the work surface and its rear is facing you.
3. *Remove the BNC connector:*
 - a. Unplug the coaxial cable from the connector.
 - b. Remove the four screws securing the connector to the rear chassis. Pull the connector away.
4. *Reinstallation:* Reinstall the BNC connector by performing step 3 in reverse.

Receptacle

1. *Assemble equipment and locate module to be removed:*
 - a. You will need a 7 mm nut driver (Item 9) and a screwdriver with a size Phillips #2 tip (Items 1 and 3).
 - b. Locate the receptacle in the *Rear chassis modules* diagram, Figure 6–7, page 6–18.
2. *Orient the analyzer:* Set the analyzer so its bottom is down on the work surface and its rear is facing you.
3. *Remove the receptacle:* See Figure 6–29.
 - a. Unplug the cable from the receptacle.
 - b. Using a 7 mm nut driver, unscrew the one nut that secures the ground lead to the rear chassis.
 - c. Using a screwdriver with a size Phillips #2 tip, remove the two screws securing the receptacle to the rear chassis. Pull the receptacle away.
4. *Reinstallation:* Reinstall the receptacle by performing step 3 in reverse.

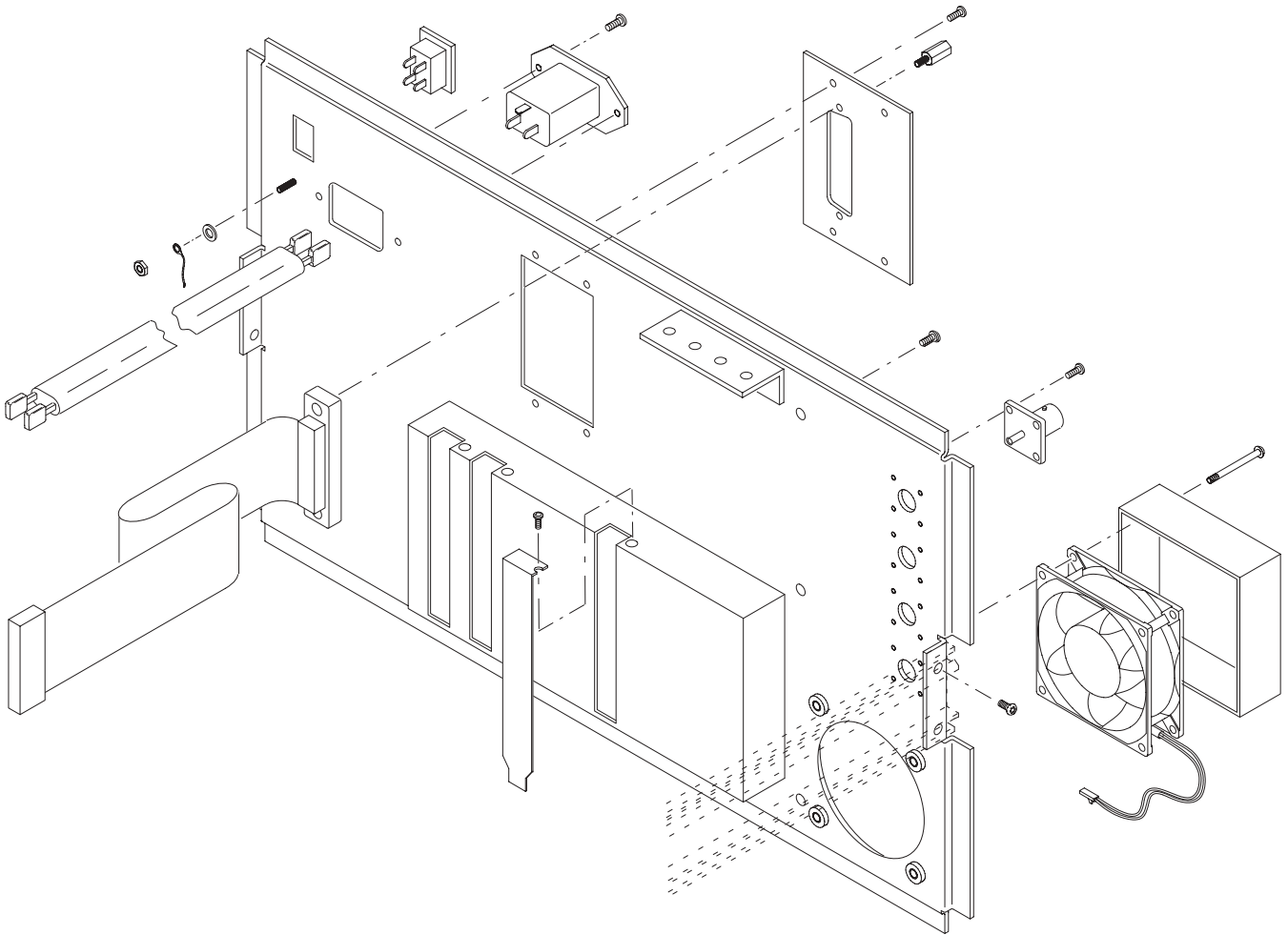


Figure 6-29: Rear chassis modules removal

Principal Power Switch

1. *Assemble equipment and locate module to be removed:* No tools are needed. Locate the principal power switch in the *Rear chassis modules* diagram, Figure 6-7, page 6-18.
2. *Orient the analyzer:* Position the analyzer so the bottom of the instrument is down on the work surface and its rear panel is facing you.
3. *Remove the principal power switch:* See Figure 6-29.
 - a. Unplug the cables from the principal power switch.
 - b. Push out the switch from the inside.
4. *Reinstallation:* Reinstall the principal power switch by performing step 3 in reverse.

Troubleshooting

This subsection contains information and procedures designed to help you isolate faulty modules in the analyzer. If a module needs to be replaced, follow the *Removal and Installation Procedures* located in this section.

Troubleshooting Procedure

This subsection consists of the following flowcharts:

- Figure 6–30: Troubleshooting Procedure 1 — Power supply system
- Figure 6–31: Troubleshooting Procedure 2 — Signal processing system
- Figure 6–32: Troubleshooting Procedure 3 — Display system

If a fault is detected, first check that the power unit is operating properly according to “Troubleshooting Procedure 1 — Power supply modules”. Then, locate the faulty board according to the troubleshooting tree for each fault or the symptom/cause table.

Note that, because of the analyzer’s operation principles, it is often difficult to locate the faulty module from the symptom or the result of the self test. You may need to replace the DDC (A20), FFT (A30), and Memory (A40) boards sequentially while rechecking operation of the analyzer.

Diagnostics

The analyzer has internal diagnostics that verify circuit functionality. The analyzer automatically executes the internal diagnostics at power-on. You can also run the internal diagnostics by using the menu selections. For more information on the diagnostics, refer to *Self Tests* on page 4–3.

Displaying the Power-On Self-Test Results

To display the power-on self-test results on screen, do the following procedures:

1. Press any key in the CONFIG area on the front panel. For example, press the CONFIG:**MODE** key.
2. Press the uppermost side key.

Running the Diagnostics

You can run the internal diagnostic routines using the menu selections described in this procedure:

Equipment Required	One 50 Ω BNC-N coaxial cable
Prerequisites	Power on the analyzer and allow a 20 minute warm-up before doing this procedure.

1. Connect the 10 MHz REF OUT connector on the rear panel through the BNC-N cable to the RF INPUT connector on the front panel.
2. Press any key in the CONFIG area on the front panel. For example, press the CONFIG:**MODE** key.
3. Press the **More...** (twice) → **Diag** side key.
4. Press the VIEW:**C** key.
5. Press the **Execute All** side key.

The results are shown in the View C on screen.

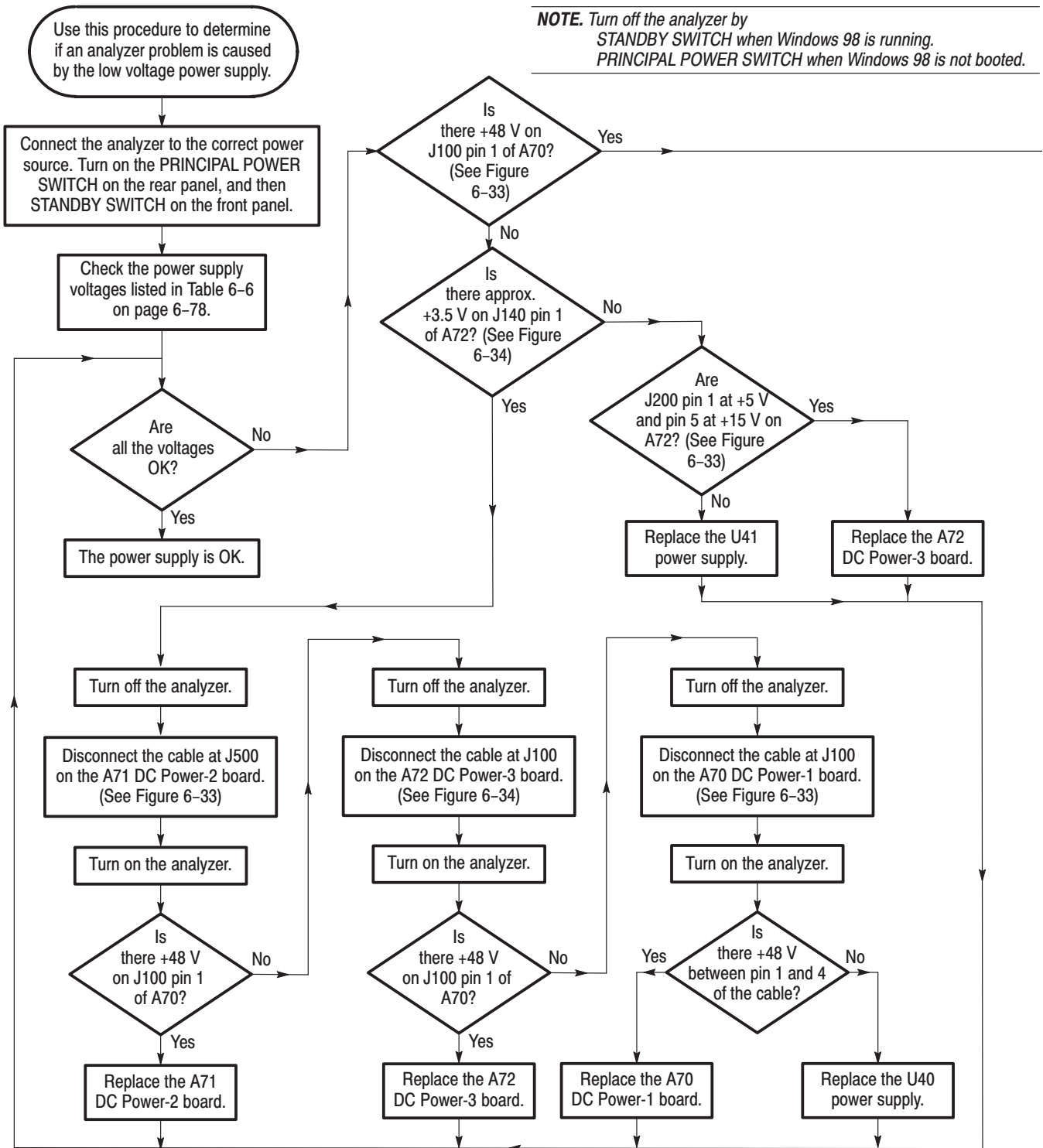
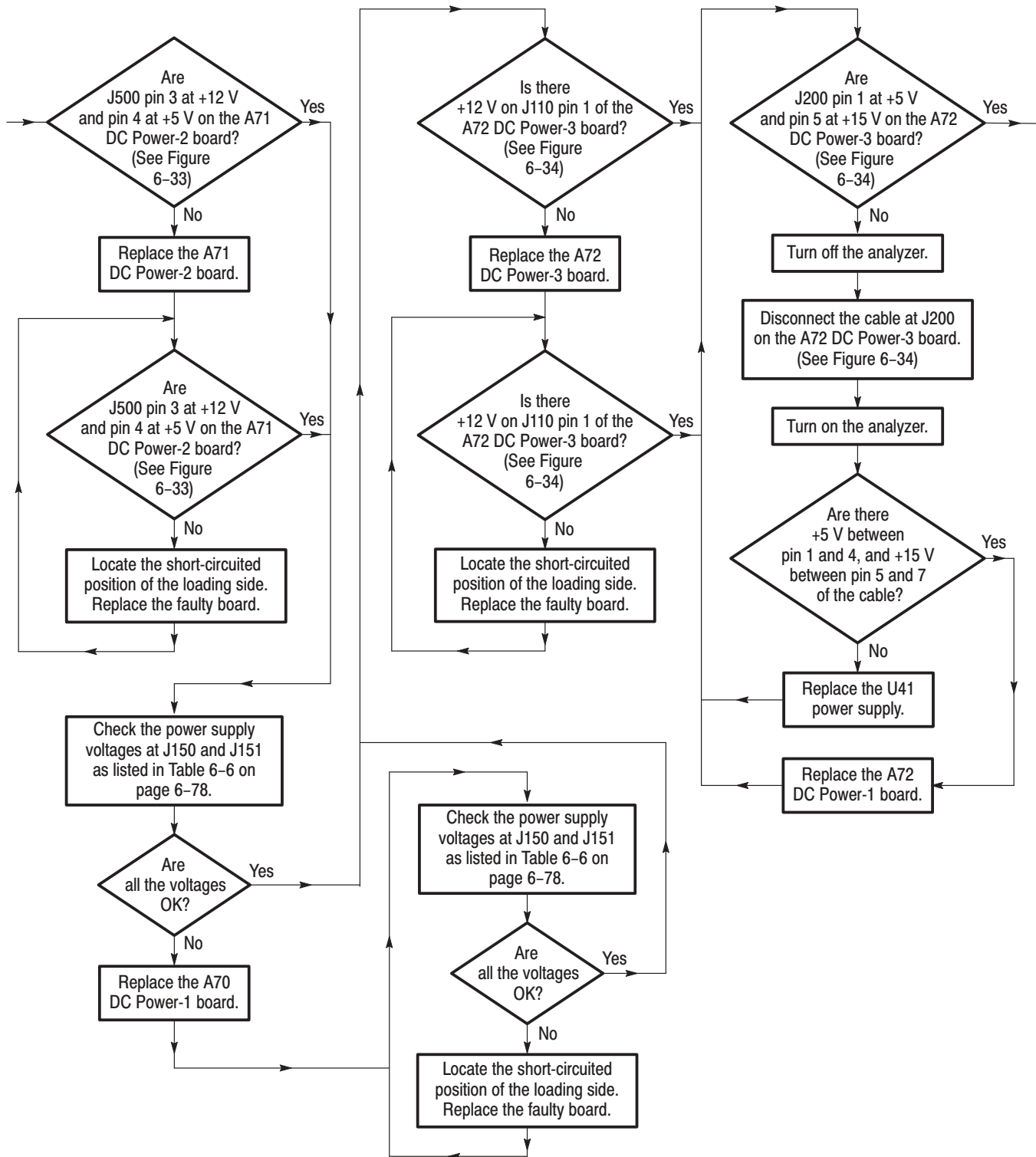
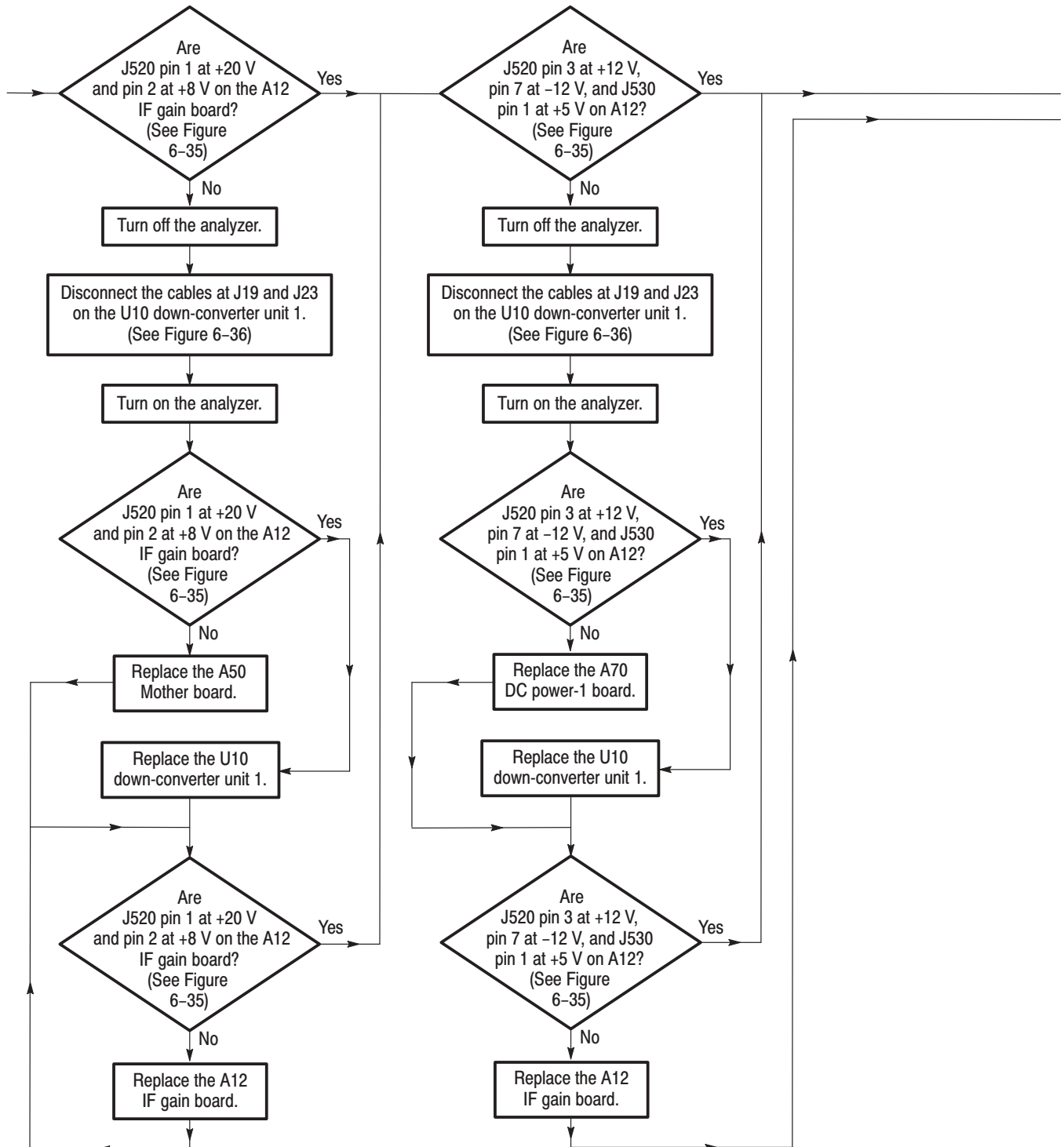
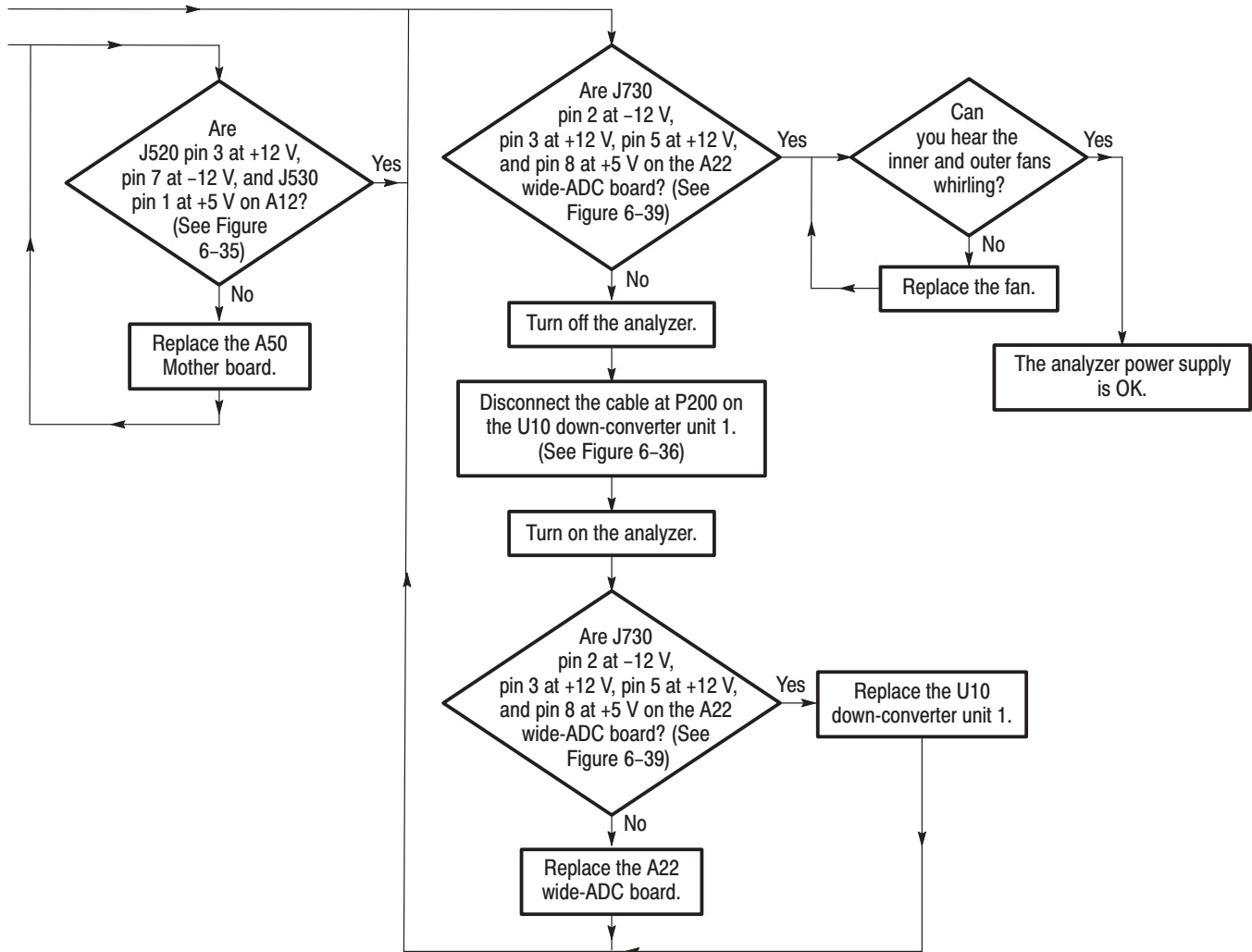


Figure 6-30: Troubleshooting procedure 1 — Power supply system







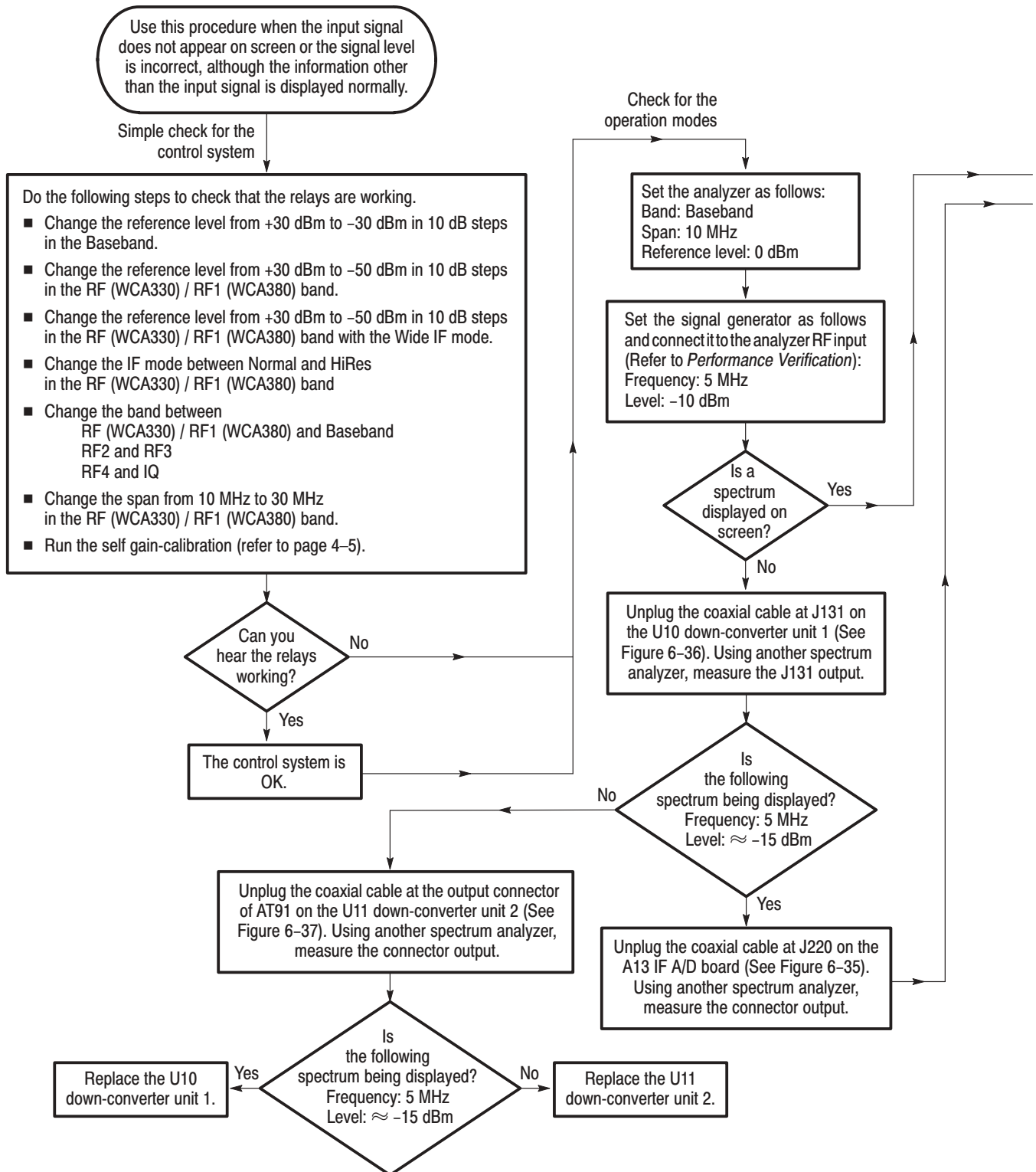
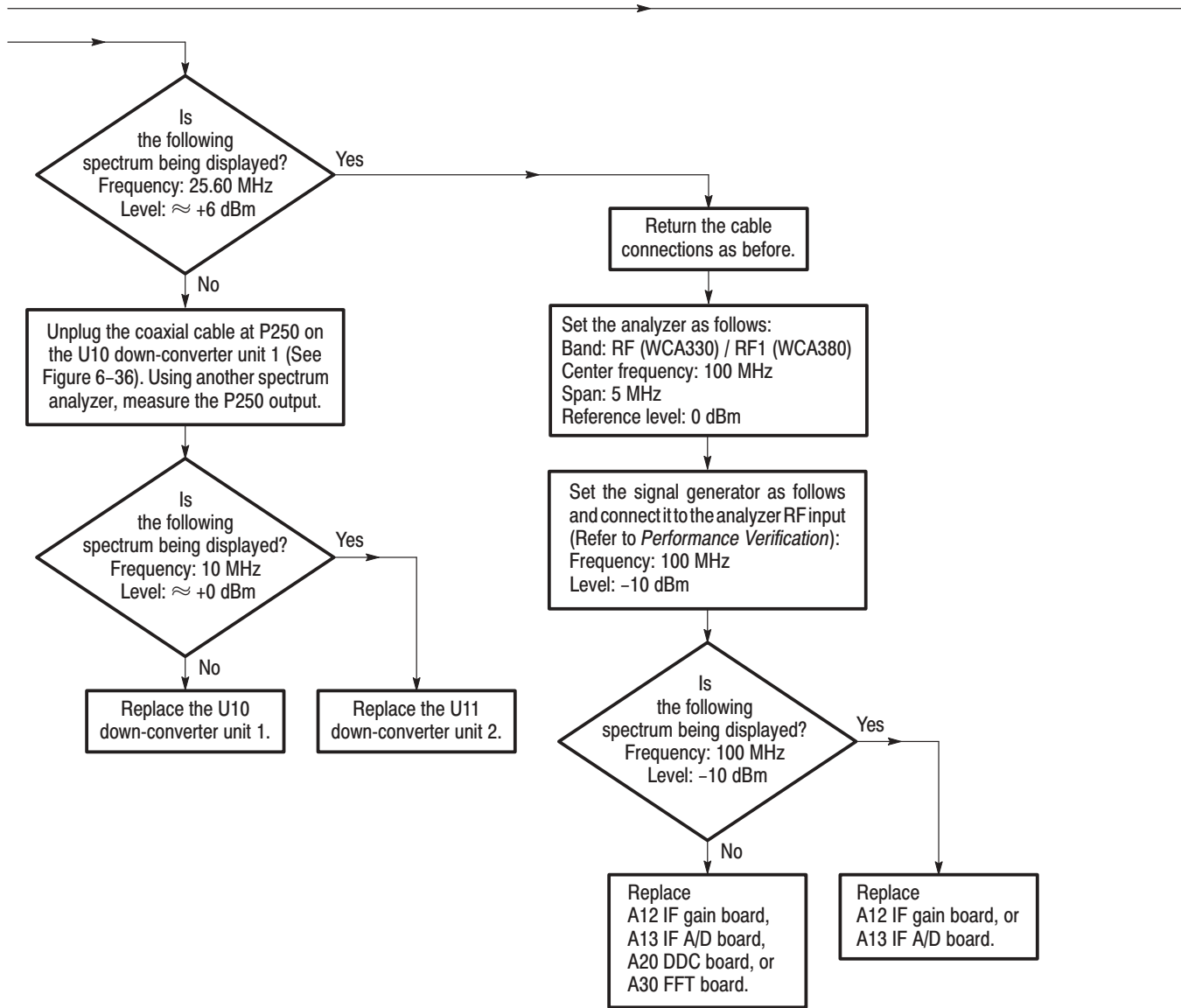
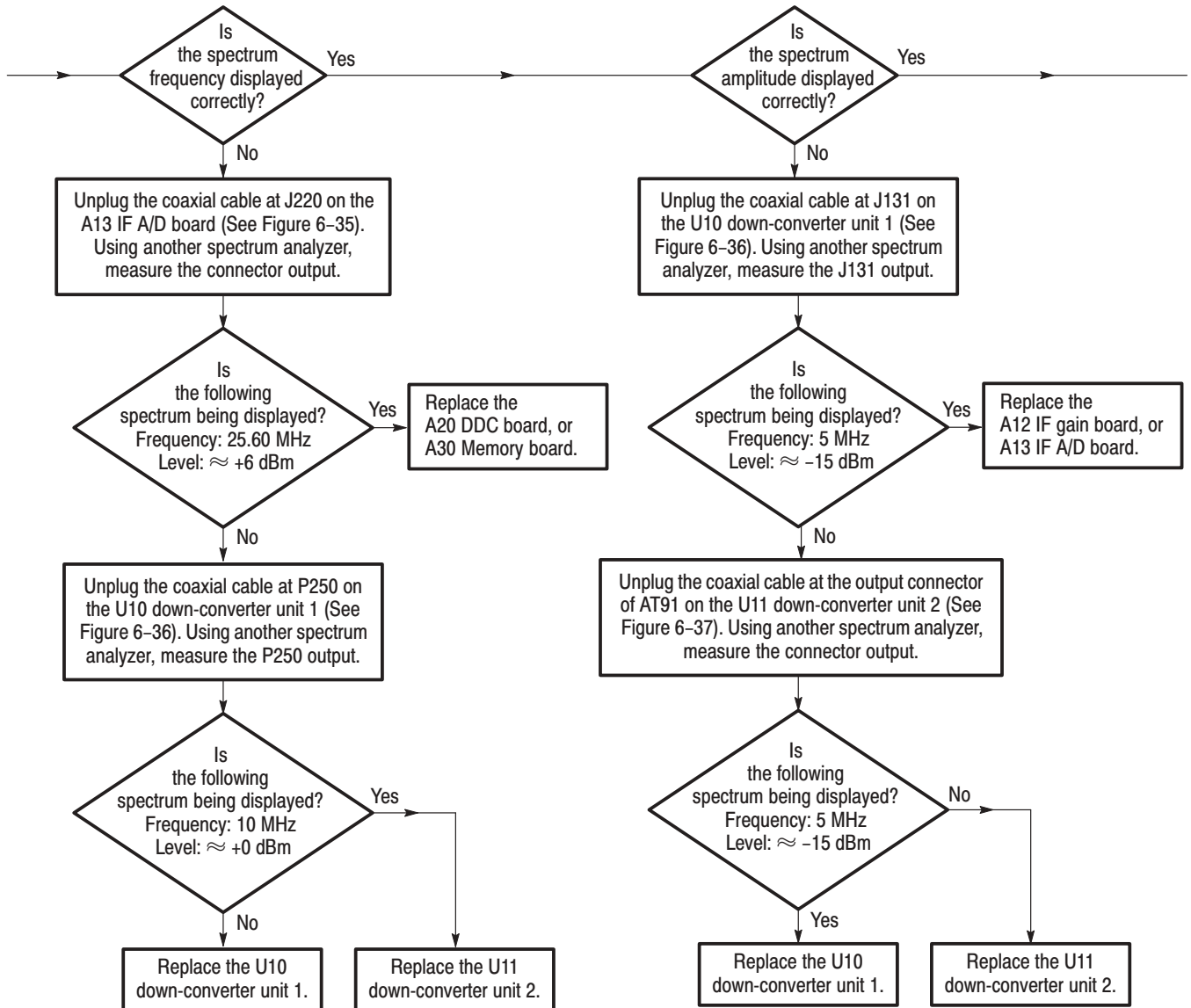
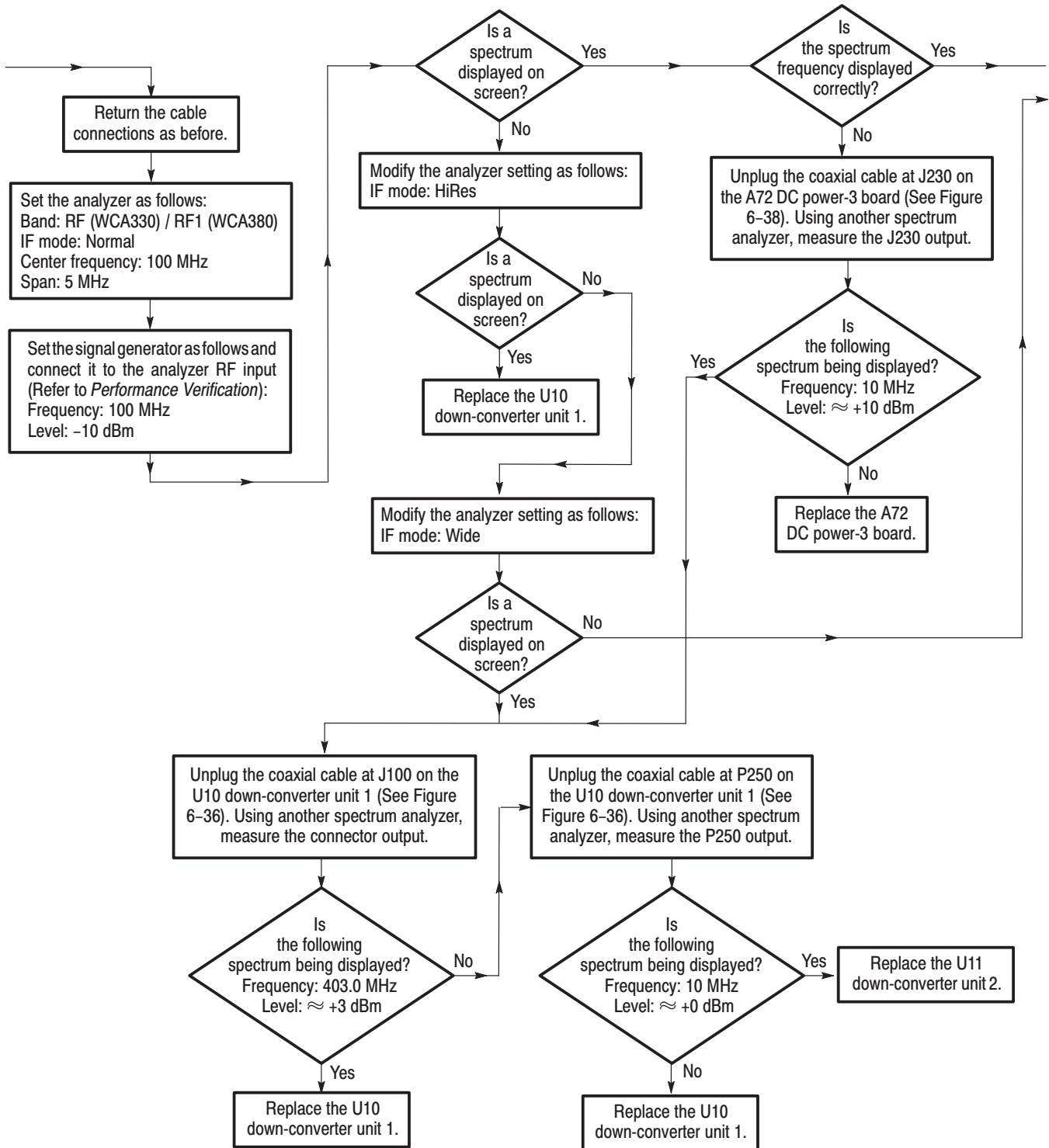
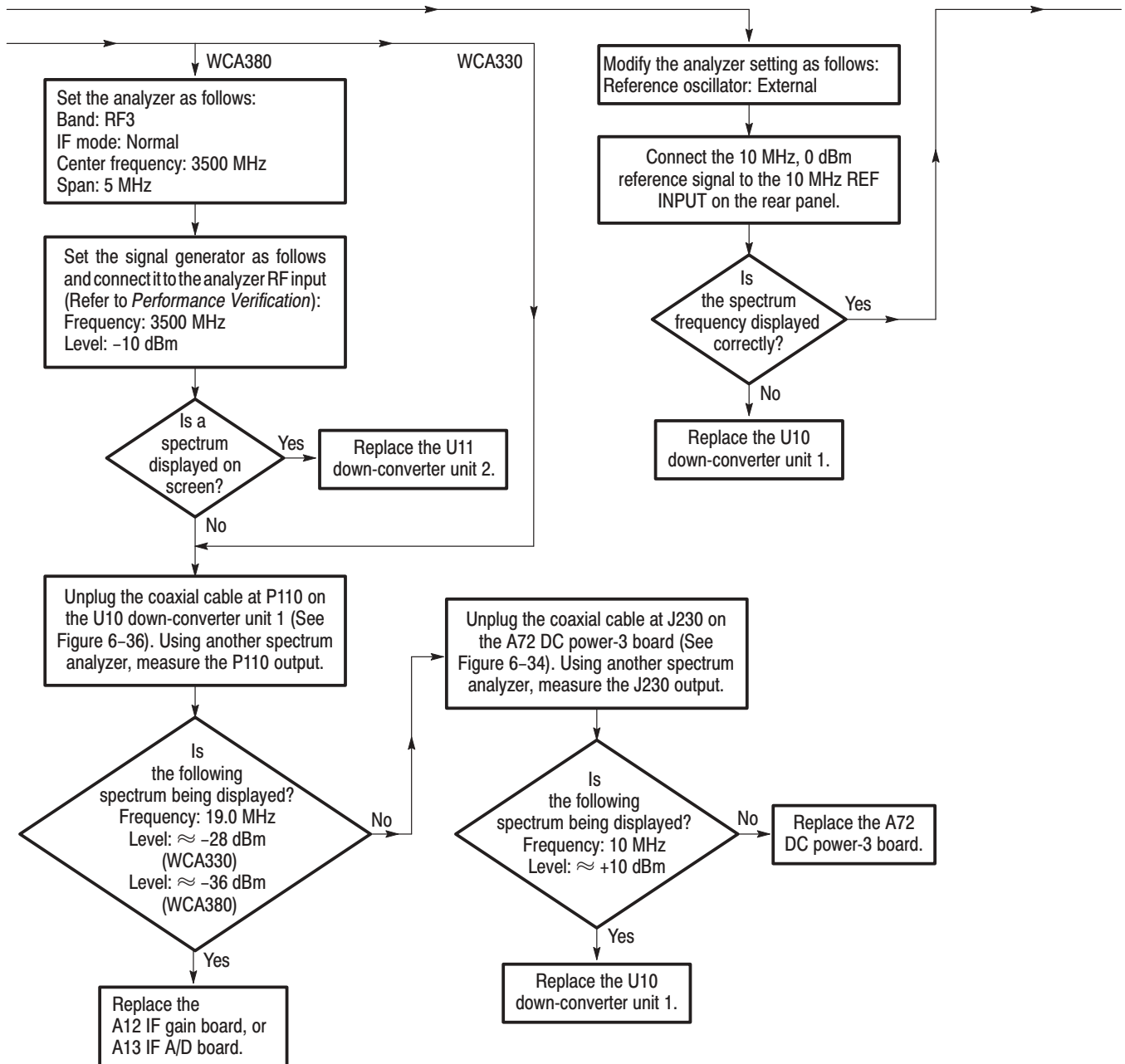


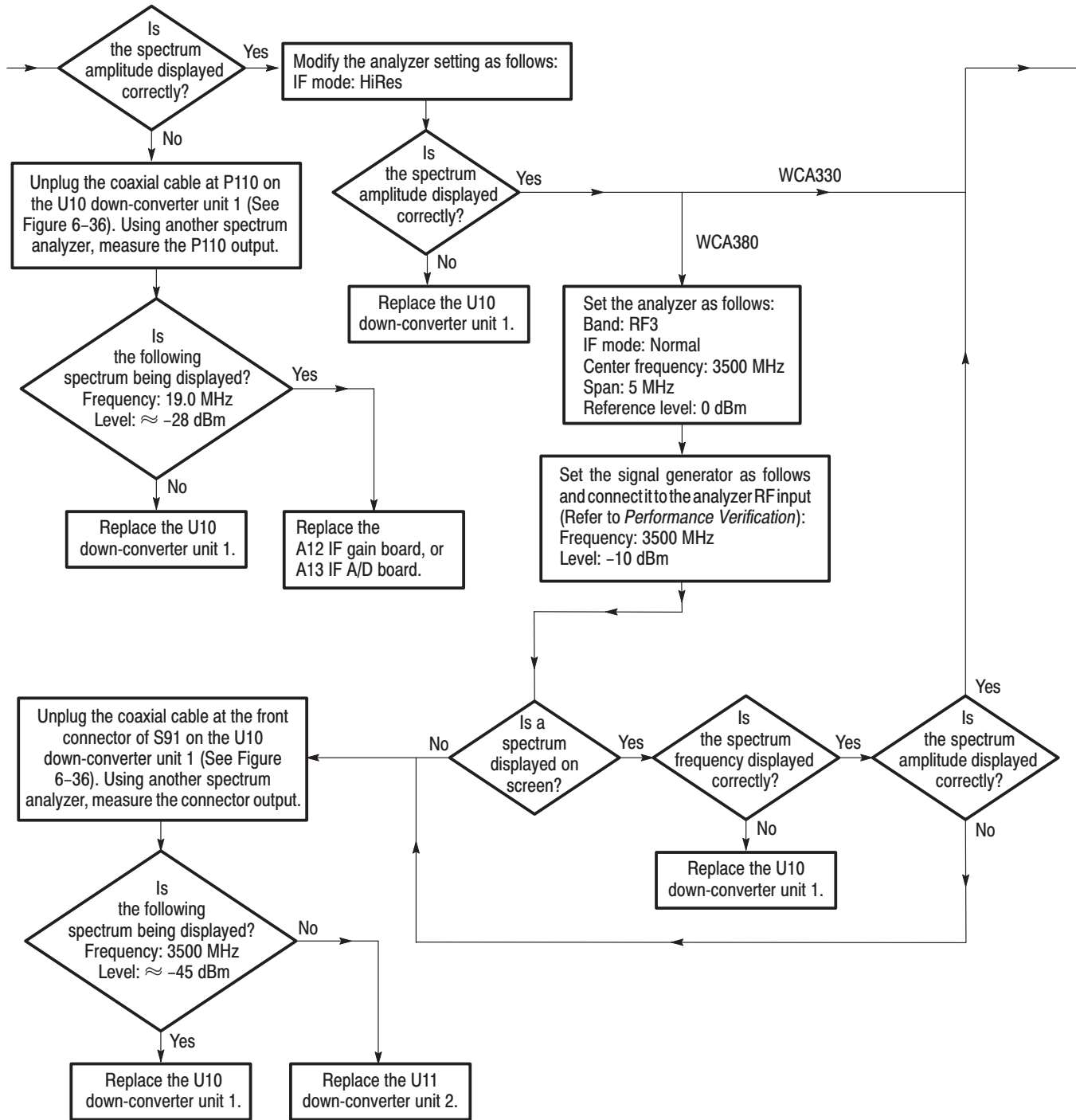
Figure 6-31: Troubleshooting procedure 2 — Signal processing system

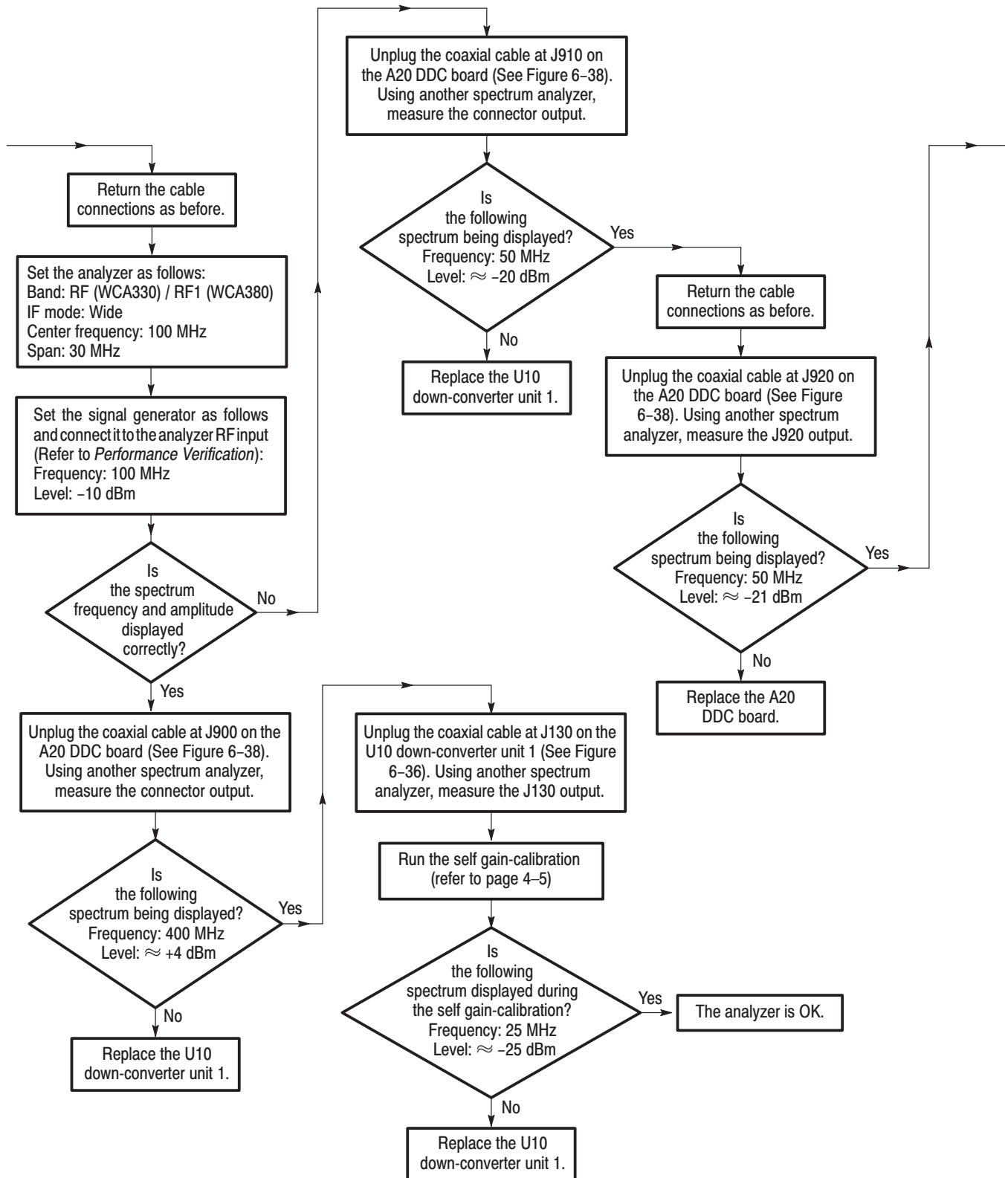


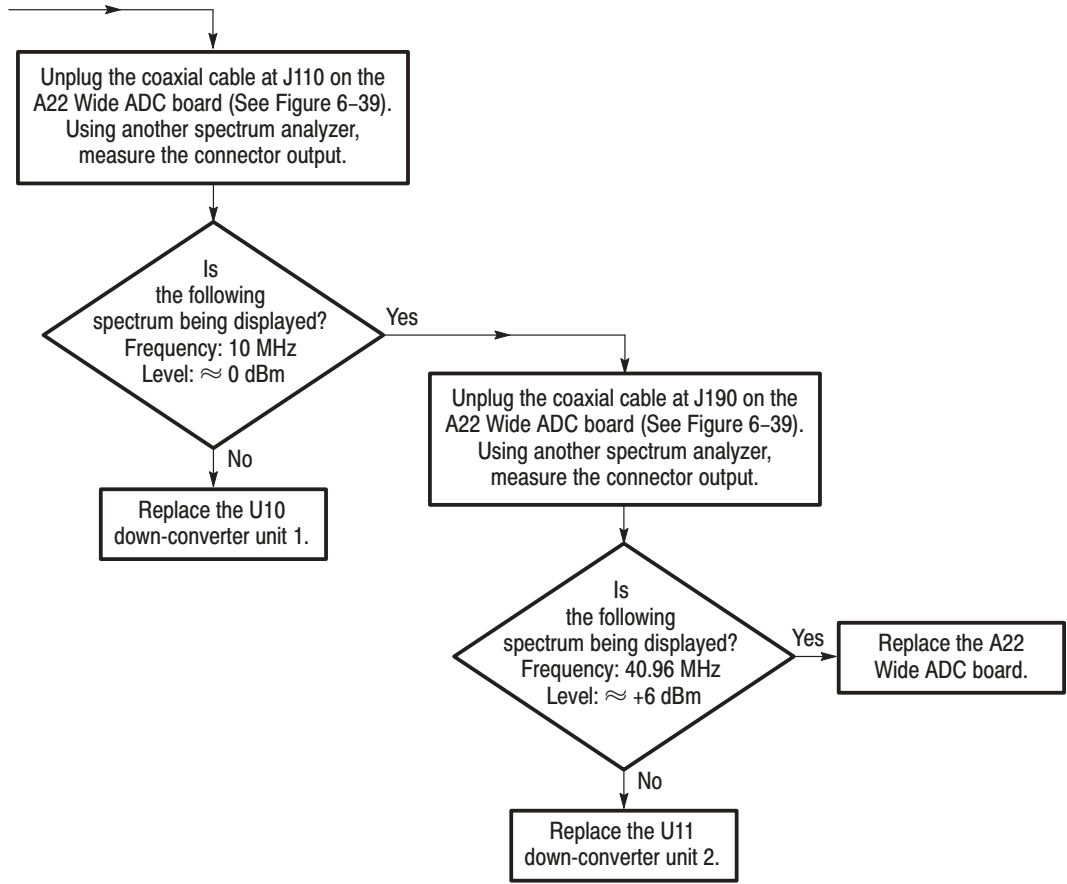












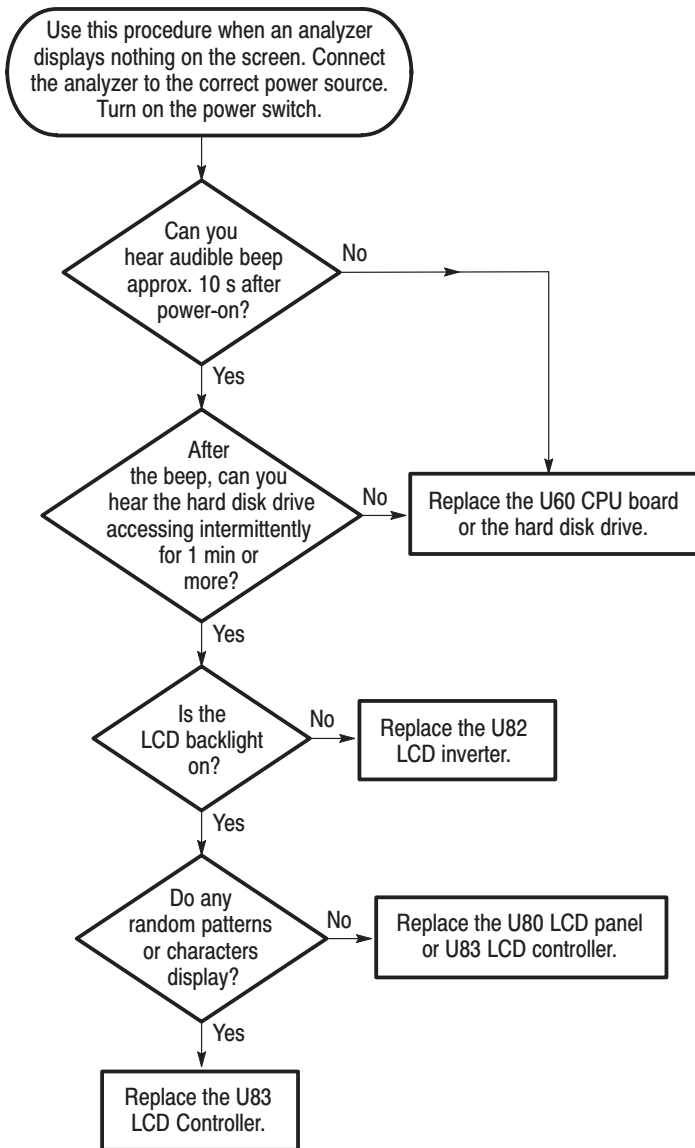


Figure 6-32: Troubleshooting procedure 3 — Display system

Table 6-6: Normal supply voltages

Board	Connector	Pin number	Voltage
A70 DC power board-1	J150	1	+24 V
		2	+12 V
		3	-12 V
		4	+12 V
	J151	1	+5 V
		2	-5 V
A71 DC power board-2	J500	3	+12 V
		4	+5 V
A72 DC power board-3	J110	1	+12 V
	J200	1	+5 V
		5	+15 V
A12 IF gain board	J520	1	+20 V
		2	+8 V
		3	+12 V
		7	-12 V
	J530	1	+5 V
	A22 Wide ADC board	J730	2
3			+12 V
5			+12 V
8			+5 V

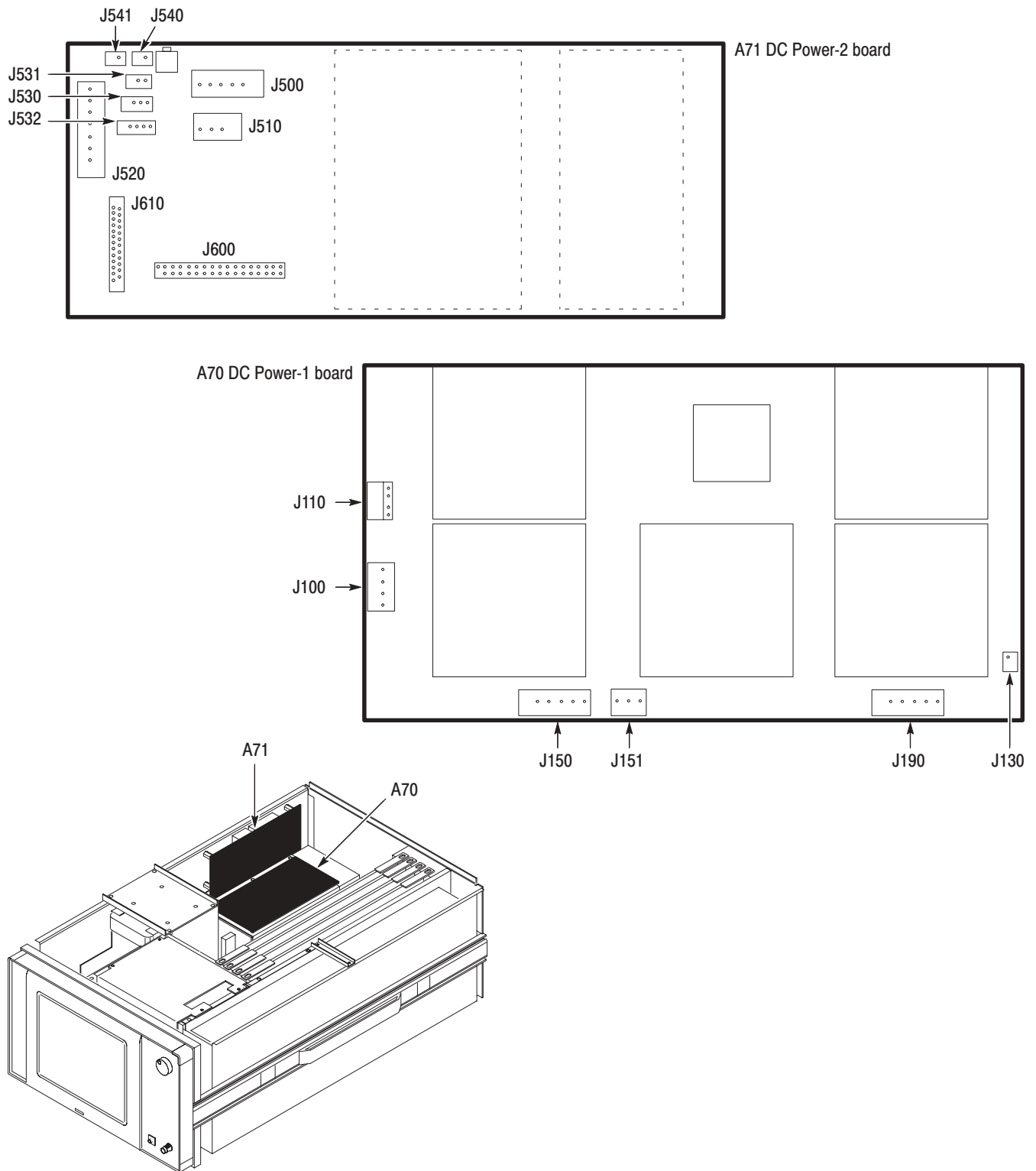


Figure 6-33: Location of the A70 and A71 DC power supply-1 and -2 boards

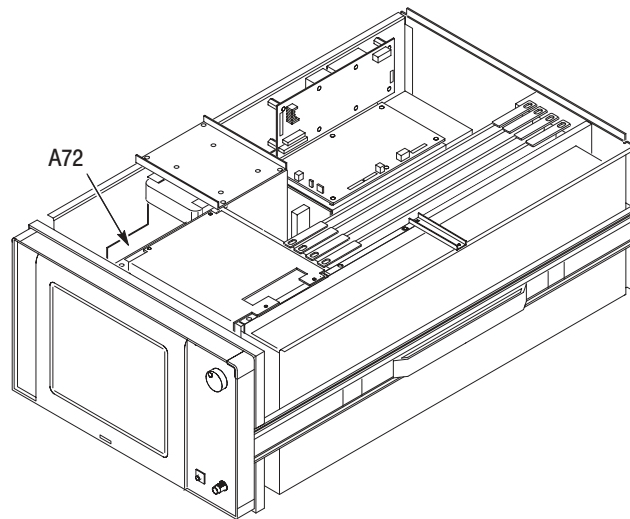
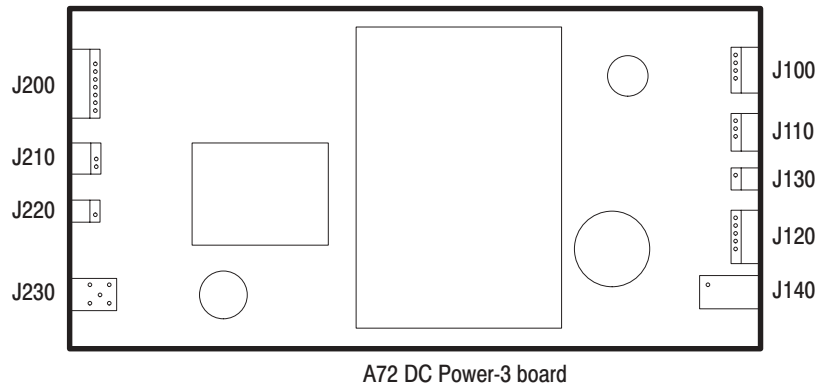
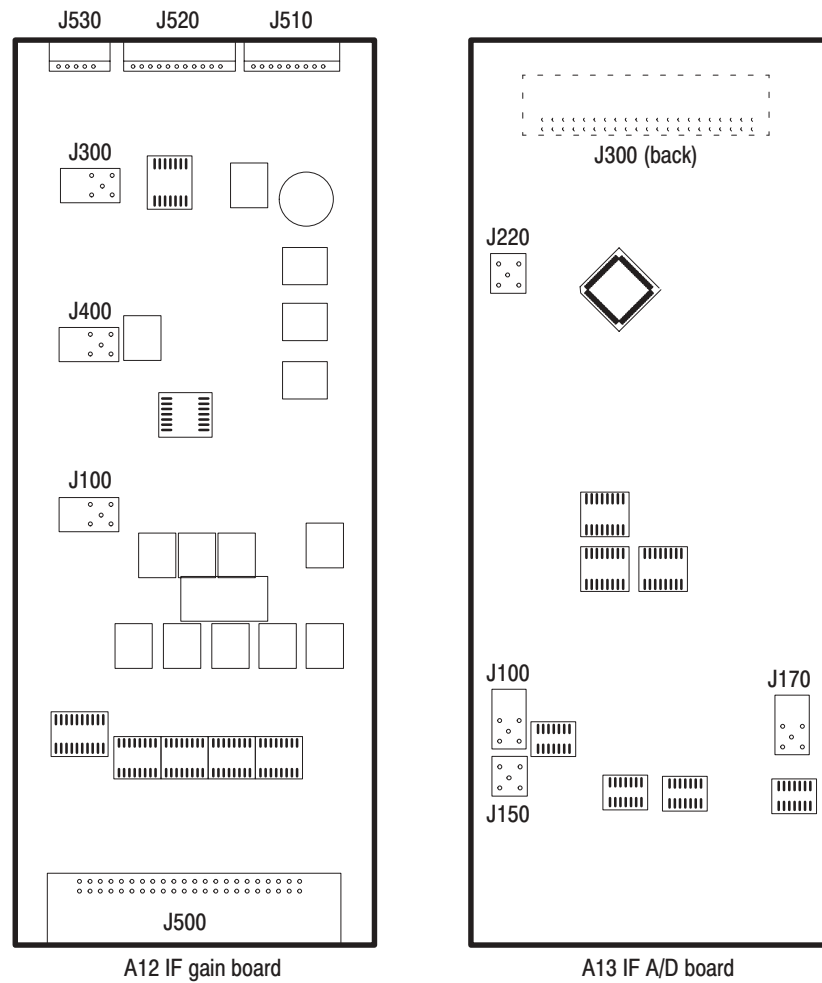


Figure 6-34: Location of the A72 DC power supply-3 boards



A12 IF gain board

A13 IF A/D board

Refer to Figure 6-14 on page 6-31 for the cable connection.

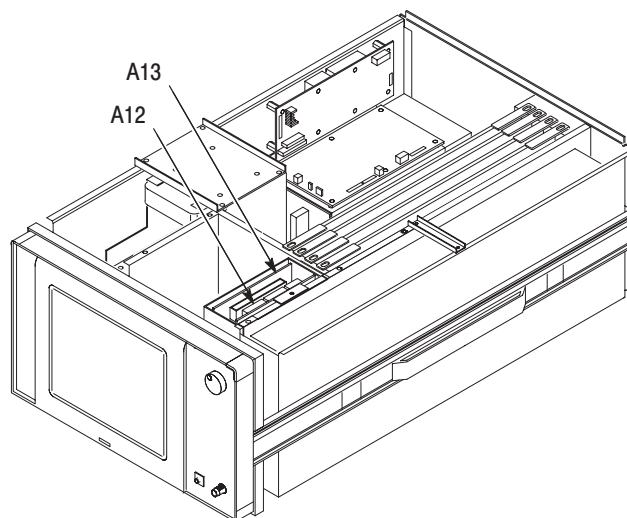


Figure 6-35: Location of A12 IF gain board and A13 IF A/D board

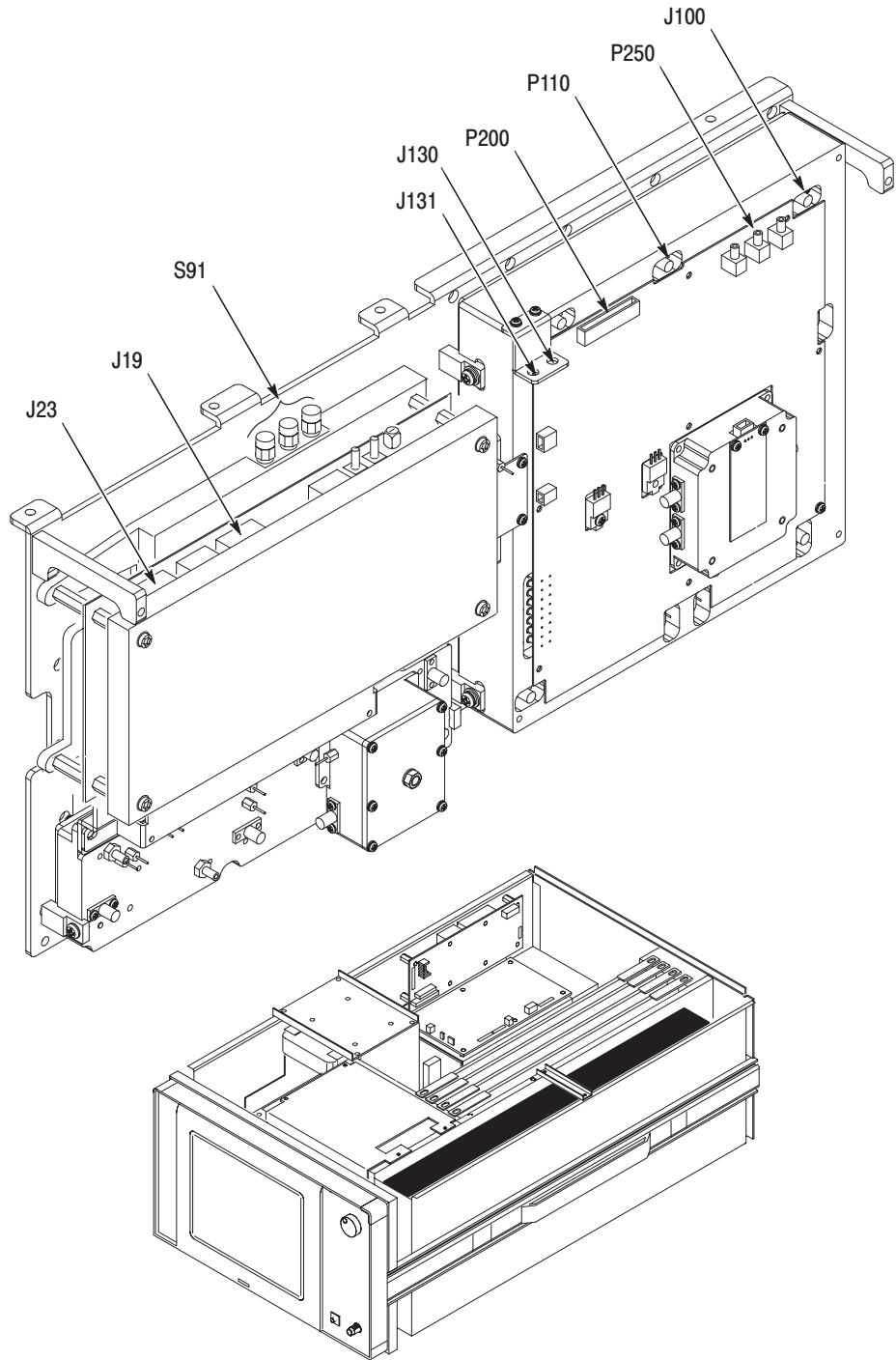


Figure 6-36: Location of the down converter unit-1

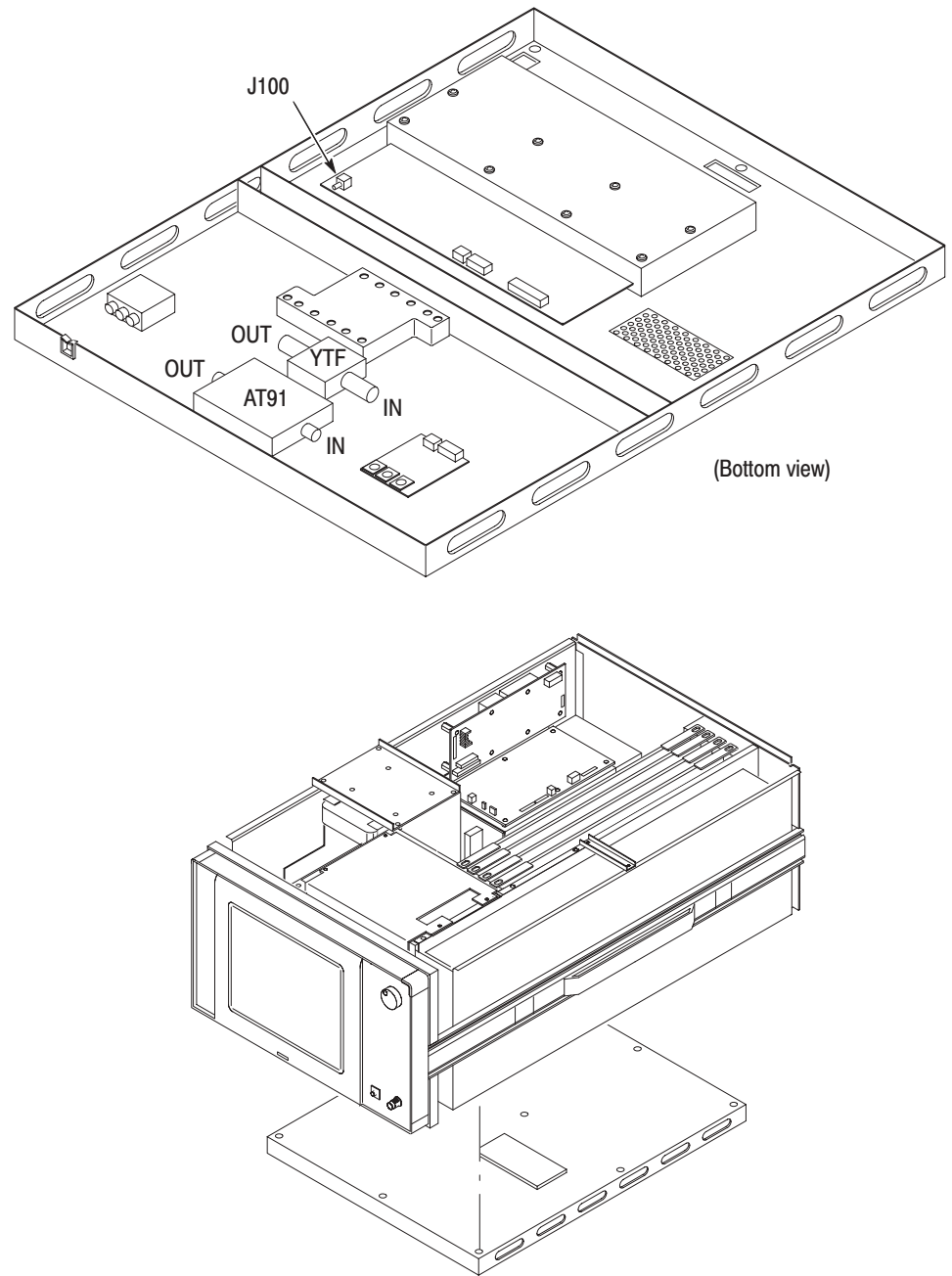


Figure 6-37: Location of the down converter unit-2

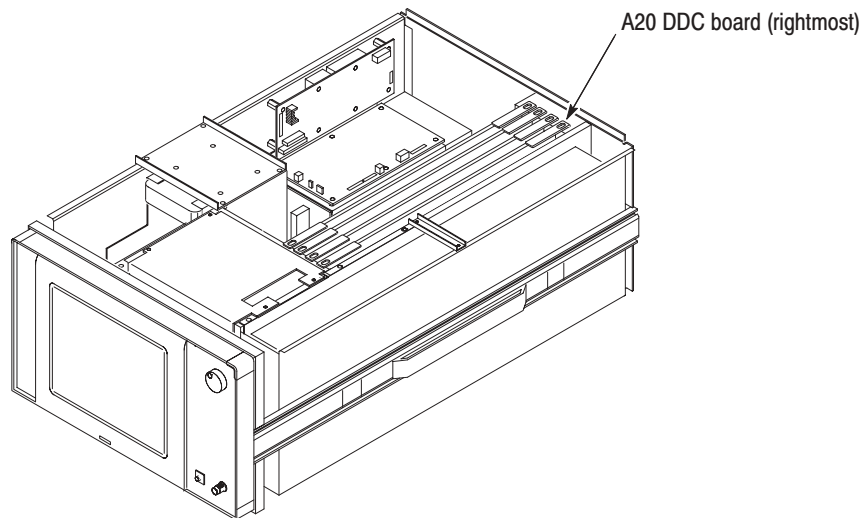
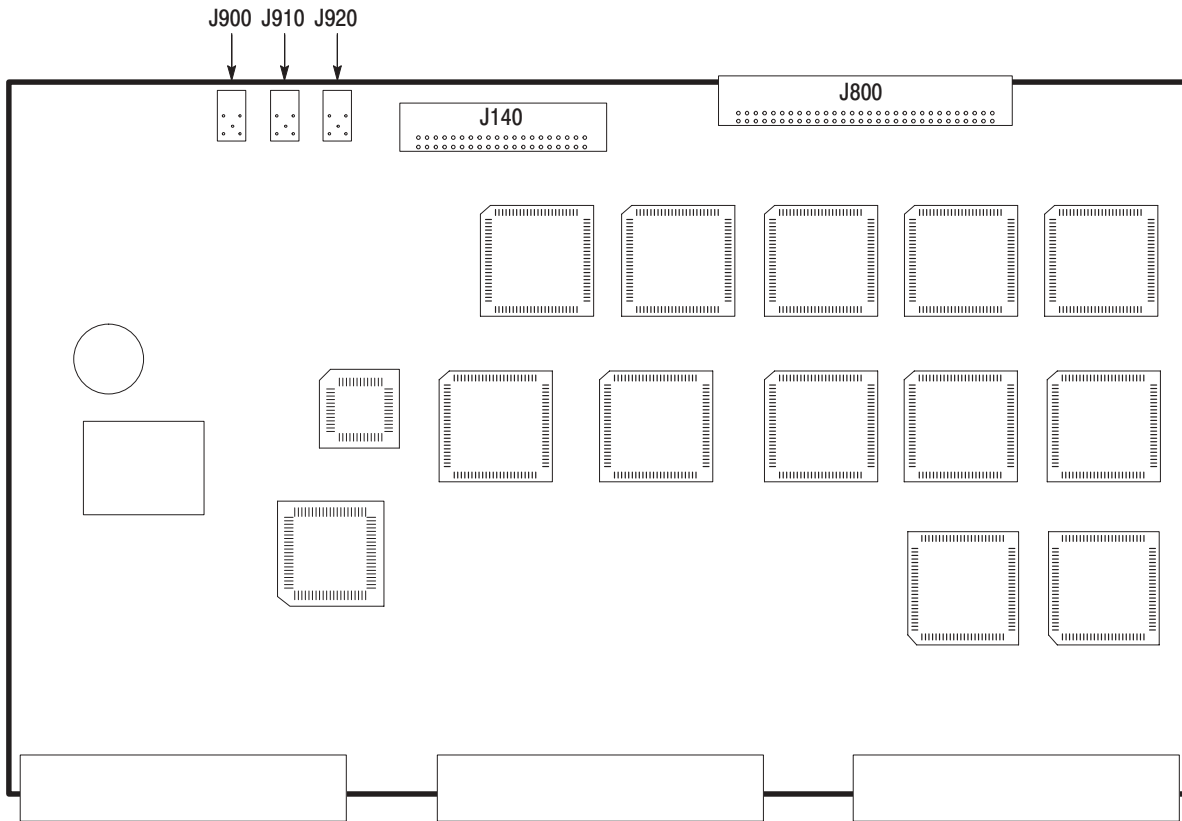


Figure 6-38: Location of the A20 DDC board

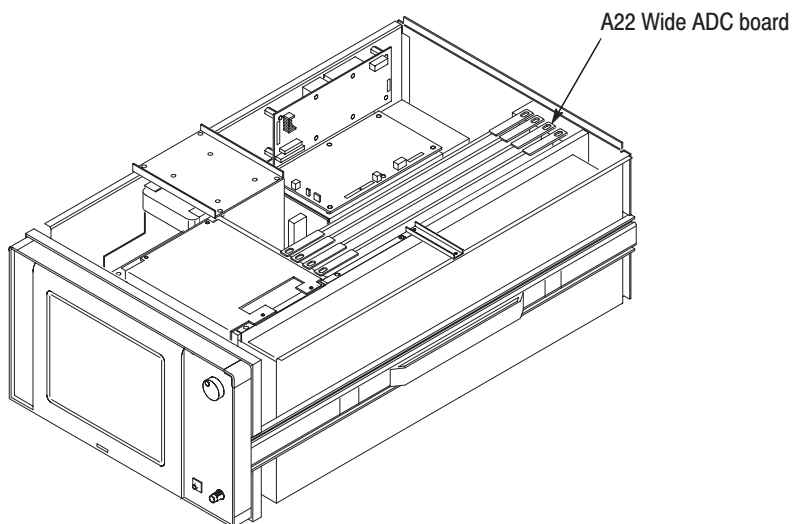
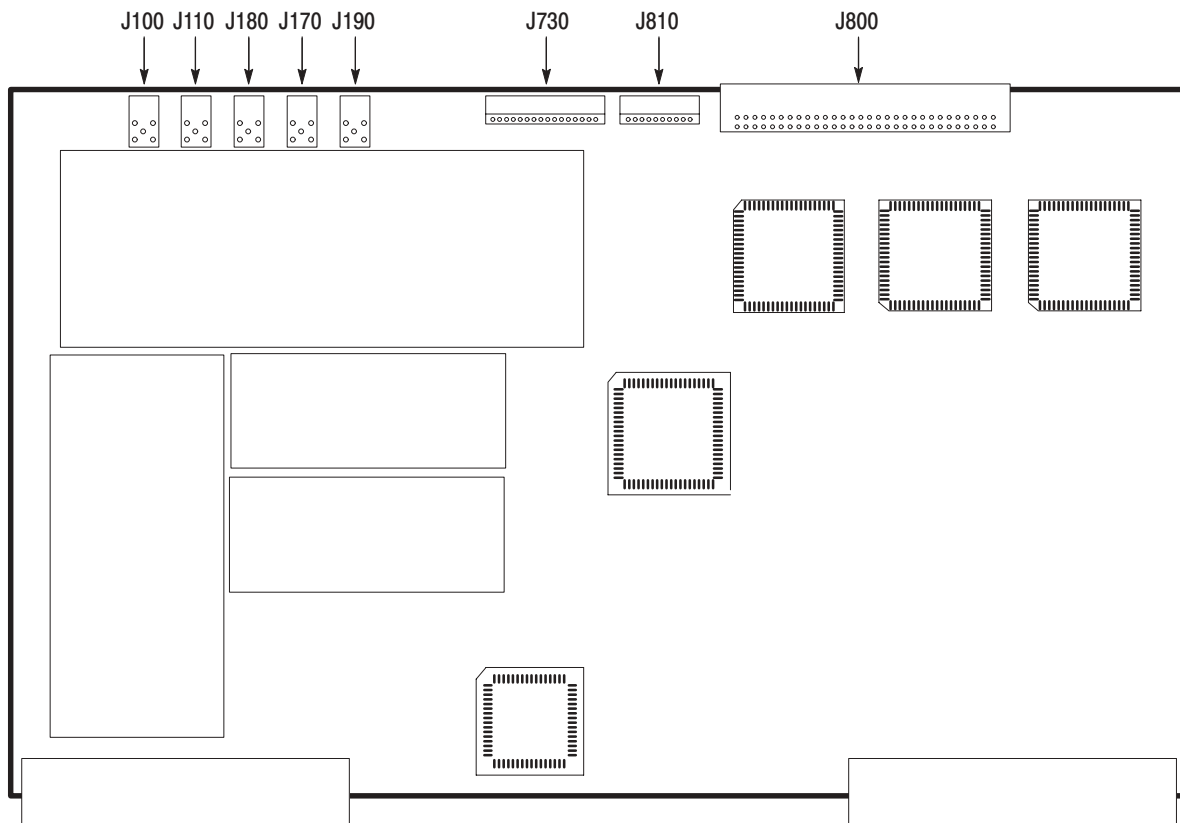


Figure 6-39: Location of the A22 Wide ADC board

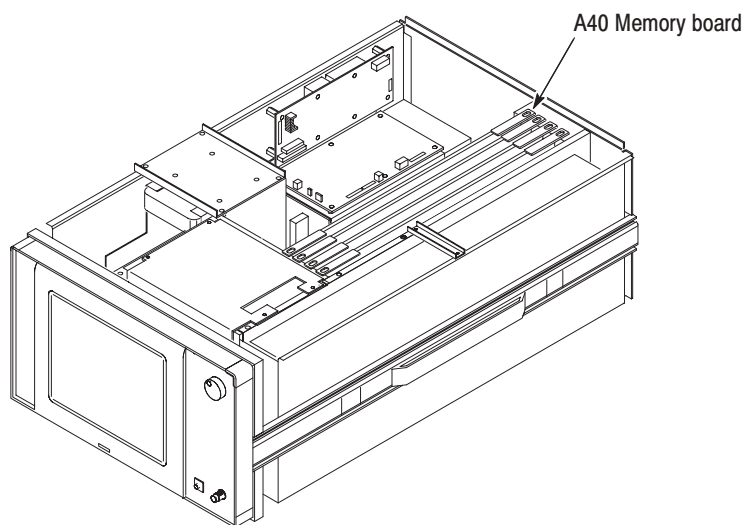
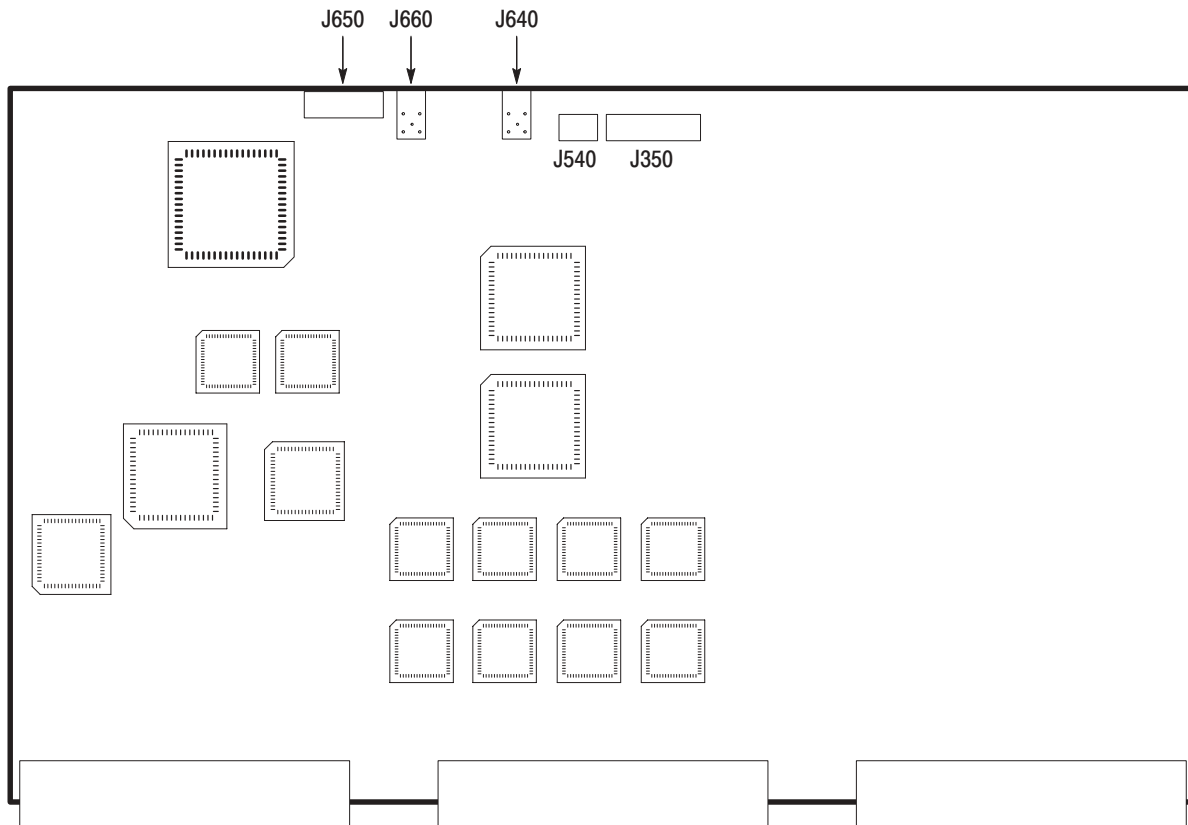


Figure 6-40: Location of the A40 Memory board

Symptoms and Faulty Modules

Table 6-7: Symptoms and faulty modules

Symptom	Possible faulty module
The power-on self-tests display "MEMORY FAIL" or indicate that the memory size is smaller than 65,536 KB.	U60 CPU board
The power-on self-tests display "FLOPPY DISK FAIL".	U50 floppy disk drive U60 CPU board
The power-on self-tests display "HARD DISK FAIL" or "SYSTEM FAIL".	U51 hard disk drive U60 CPU board
The power-up sequence is followed by the initial screen of the Windows 98 instead of that of the analyzer.	A40 Memory board A50 Mother board
A fault occurs only in the RF mode.	U10 down-converter unit 1 U11 down-converter unit 2 A12 IF gain board A13 IF A/D board
A fault occurs only in the Baseband mode.	A12 IF gain board A13 IF A/D board A20 DDC board
The same symptom is found in both the RF and Baseband modes.	U11 down-converter unit 2 A12 IF gain board A13 IF A/D board A20 DDC board A30 FFT board A40 Memory board
In the RF mode, the spectrum displayed goes abnormal only with 10 MHz or more of span.	U10 down-converter unit 1
In both of the RF and Baseband modes, the spectrum displayed goes abnormal with a certain span.	A20 DDC board
A fault occurs only at 256 or 1024 of FFT points.	A30 FFT board
Either odd or even frames are faulty.	A30 FFT board
The Zoom mode does not work. (The Freq mode and Dual mode are OK)	A20 DDC board A40 Memory board
In the Dual mode, either the time domain (Time-I and Time-Q) or the frequency domain data (Freq-I and Freq-Q) is faulty.	A30 FFT board A40 Memory board
In the RF mode, a fault occurs in a certain center frequency setting.	U10 down-converter
In both of the RF and Baseband modes, a fault occurs in a certain center frequency setting.	A20 DDC board
In the Baseband mode, a fault occurs only with a certain center frequency.	A20 DDC board

Table 6-7: Symptoms and faulty modules (Cont.)

Symptom	Possible faulty module
A fault occurs only for the time domain data (Time-Ampl, Time-I, and Time-Q).	A30 FFT board A40 Memory board
A fault occurs only for the frequency domain data (Freq-Ampl, Freq-I, and Freq-Q).	A30 FFT board A40 Memory board
A fault occurs only for the in-phase data (Time-I and Freq-I).	A20 DDC board A30 FFT board
A fault occurs only for the quadrature data (Time-Q and Freq-Q).	A20 DDC board A30 FFT board
A fault occurs only for a certain frame period.	A30 FFT board
A fault occurs only for a certain block size.	A40 Memory board
The internal trigger is disabled.	A30 FFT board A40 Memory board
The external trigger is disabled.	A40 Memory board
The analyzer cannot be shut down with the STANDBY switch.	A72 DC Power-3 board U60 CPU board
A fault occurs only in the Wide IF mode.	U10 down-converter A22 Wide ADC board

Options

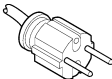
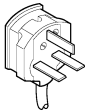

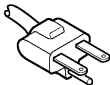
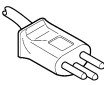

Options and Accessories

This chapter describes the various options as well as the standard and optional accessories that are available for the WCA330 and WCA380 Wireless Communication Analyzers.

Options

Options available for this instrument are listed in Table 7-1.

Table 7-1: Options

	Option #	Label	Description
	A1	Universal European power cord	230 V, 50 Hz power cord Fuse 5A (T) (IEC 127) Fuse Cap Cable Retainer
	A2	UK power cord	230 V, 50 Hz power cord Fuse 5A (T) (IEC 127) Fuse Cap Cable Retainer
	A3	Australian power cord	240 V, 50 Hz power cord
	A4	North American power cord	220 V, 60 Hz power cord
	A5	Switzerland power cord	220 V, 50 Hz power cord
	AC	China power cord	220 V, 10A, 50 Hz power cord
	A99		No power cord
	1R	Rackmount	Spectrum Analyzer comes configured for installation in a 19 inch wide instrument rack. For later field conversions, order kit # 016-1754-XX.

Standard Accessories

The analyzer comes standard with the accessories listed in Table 7–2.

Table 7–2: Standard accessories

Accessory	Part number
User manual	070-A752-XX
Programmer manual	070-A754-XX
U.S. power cord	161-0066-XX
Keyboard	119-B061-XX
Mouse	119-B063-XX
BNC–N adapter	103-0045-XX

Optional Accessories

You can also order the optional accessories listed in Table 7–3.

Table 7–3: Optional accessories

Accessory	Part number
Service manual	070-A755-XX
Rack mount kit (for field conversion)	016-1754-XX
Data display and analysis software for PC	SL7PCW3

Electrical Parts List

Electrical Parts List

The modules that make up this instrument are often a combination of mechanical and electrical subparts. Therefore, all replaceable modules are listed in section 10, *Mechanical Parts List*. Refer to that section for part numbers when using this manual.

Diagrams

Diagrams

This section contains the following diagrams:

- Block diagram: Shows the modules and functional blocks.
- Interconnect diagram: Shows how the modules connect together.

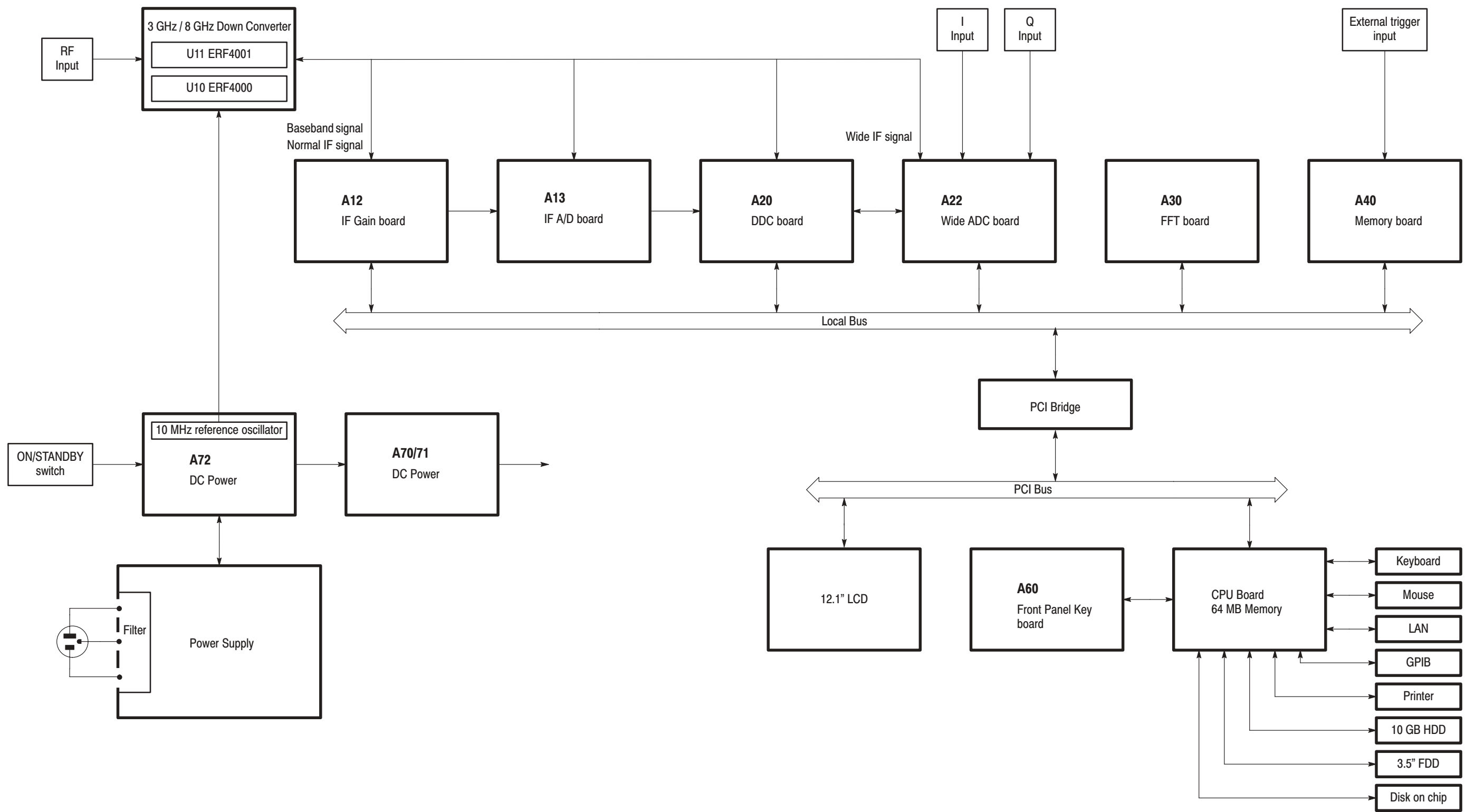


Figure 9-1: Block diagram

Mechanical Parts List

Mechanical Parts List

This section contains a list of the replaceable modules for the WCA330 and WCA380 analyzers. Use this list to identify and order replacement parts.

Parts Ordering Information

Replacement parts are available through your local Tektronix field office or representative.

Changes to Tektronix instruments are sometimes made to accommodate improved components as they become available and to give you the benefit of the latest circuit improvements. Therefore, when ordering parts, it is important to include the following information in your order.

- Part number
- Instrument type or model number
- Instrument serial number
- Instrument modification number, if applicable

If you order a part that has been replaced with a different or improved part, your local Tektronix field office or representative will contact you concerning any change in part number.

Change information, if any, is located at the rear of this manual.

Part Number Revision Level

Tektronix part numbers contain two digits that show the revision level of the part. For most parts in this manual, you will find the letters XX in place of the revision level number.



When you order parts, Tektronix will provide you with the most current part for your product type, serial number, and modification (if applicable). At the time of your order, Tektronix will determine the part number revision level needed for your product, based on the information you provide.

Module Servicing

Modules can be serviced by selecting one of the following three options. Contact your local Tektronix service center or representative for repair assistance.

Module Exchange. In some cases you may exchange your module for a remanufactured module. These modules cost significantly less than new modules and meet the same factory specifications. For more information about the module exchange program, call 1-800-TEK-WIDE, extension 6630.

Module Repair and Return. You may ship your module to us for repair, after which we will return it to you.

New Modules. You may purchase replacement modules in the same way as other replacement parts.

Using the Replaceable Parts List

This section contains a list of the mechanical and/or electrical components that are replaceable for the analyzer. Use this list to identify and order replacement parts. The following table describes each column in the parts list.

Parts List Column Descriptions

Column	Column Name	Description
1	Figure & Index Number	Items in this section are referenced by component number.
2	Tektronix Part Number	Use this part number when ordering replacement parts from Tektronix.
3 and 4	Serial Number	Column three indicates the serial number at which the part was first effective. Column four indicates the serial number at which the part was discontinued. No entries indicates the part is good for all serial numbers.
5	Qty	This indicates the quantity of parts used.
6	Name & Description	An item name is separated from the description by a colon (:). Because of space limitations, an item name may sometimes appear as incomplete. Use the U.S. Federal Catalog handbook H6-1 for further item name identification.
7	Mfr. Code	This indicates the code of the actual manufacturer of the part. (Code to name and address cross reference is located after this page.)
8	Mfr. Part Number	This indicates the actual manufacturer's or vendor's part number if other than Tektronix, Inc.

Abbreviations

Abbreviations conform to American National Standard ANSI Y1.1-1972.

Mfr. Code to Manufacturer Cross Index

The following table cross indexes codes, names, and addresses of manufacturers or vendors of components listed in the parts list.

Manufacturers Cross Index

Mfr. Code	Manufacturer	Address	City, State, Zip Code
S0482	SONY CONSUMER ELECTRONICS	TOKYO JAPAN	,
S4238	STANLEY ELECTRIC CO	TJBO LIAISON M/S 78-210	BEAVERTON, OR 97077
S0482	SONY CONSUMER ELECTRONICS	TOKYO JAPAN	,
S3109	FELLER U.S. CORPORATION	68 VERONICA AVE, UNIT #5	SOMERSET, NJ 08873
TK0191	SONY/TEKTRONIX	PO BOX 5209 TOKYO INTERNATIONAL	TOKYO, JP 100-3199
TK0198	AVNET INC	AVNET/MARSHALL 15580 SW JAY STREET	BEAVERTON, OR 97006
TK1373	PATELEC-CEM	10156 TORINO VAICENTALLO 62/456	ITALY,
0B445	ELECTRI-CORD MFG CO INC	312 EAST MAIN STREET	WESTFIELD, PA 16950
0J260	COMTEK MANUFACTURING OF OREGON	P O BOX 4200 M/S 16-207	BEAVERTON, OR 970764200
12136	PHC INDUSTRIES INC	1643 HADDON AVE PO BOX 1448	CAMDEN, NJ 08103
3M099	PORTLAND SCREW COMPANY	6520 N BASIN AVE	PORTLAND, OR 97217
6E390	POWELL ELECTRONICS INC	2260 LUNDY AVE	SAN JOSE, CA 95131
80009	TEKTRONIX INC	14150 SW KARL BRAUN DR PO BOX 500	BEAVERTON OR 97077-0001
93907	CAMCAR DIV OF TEXTRON INC	ATTN: ALICIA SANFORD 516 18TH AVE	ROCKFORD, IL 611045181

Replaceable Parts List

Fig. & Index Number	TektronixPart Number	Serial No. Effective	Serial No. Discont'd	Qty	Name & Description	Mfr. Code	Mfr. Part Number
10-1							
-1	390-1195-XX			1	CABINET,TOP:.,AL	80009	
-2	334-9930-XX			1	MARKER,IDENT:MKD CAUTION,POLYESTER	80009	
-3	334-A522-XX			1	MARKER,IDENT:MKD HEAVY PRODUCT	80009	
-4	161-0066-XX			1	CABLE ASSY,PWR:.,3,18 AWG,92 L,SVT,TAN (STANDARD ACCESSORY)	0B445	ECM-161-0066-00
-5	211-1025-XX			10	SCREW,MACHINE:M3X8MM L,TRUSS HD,STL,NI PL CROSS REC	80009	
-6	343-1514-XX			2	RETAINER,CAB:POLYCARBONATE	80009	
-7	211-0945-XX			16	SCREW,MACHINE:M4X8MM L,STL,ZN-C,CROSS REC	80009	
-8	367-0116-XX			2	HANDLE,CARRYING:16.54 L,BLUE VINYL	12136	ORDER BY DESCRIPTION
-9	212-0628-XX			8	SCREW,SHOULDER:10-32 X 0.4 L,RDH,STL ZN-CM1, POZIDRIV	93907	ORDER BY DESCRIPTION
-10	386-1624-XX			4	PLATE,HDL RTNG:STAINLESS STEEL	0J260	ORDER BY DESCRIPTION
-11	386-6340-XX			4	PLATE,HANDLE:MOUNTING	80009	
-12	211-0945-XX			4	SCREW,MACHINE:M4X8MM L,STL,ZN-C,CROSS REC	80009	
-13	348-A121-XX			230 CM	GASKET SHIELD:MESH TYPE,1.5MM OD,SI CORE	80009	
-14	426-2587-XX			2	FRAME,SECTION,CAB:AL	80009	
-15	200-4017-XX			4	COVER,HANDLE:ABS	80009	
-16	390-1194-XX			1	CABINET,BOTTOM:.,AL	80009	
-17	348-0128-XX			4	FOOT,CABINET:BLACK POLYURETHANE	80009	
-18	211-1020-XX			8	SCREW,MACHINE:M4X16MM L,PNH STL,ZN-C,CROSS REC	80009	

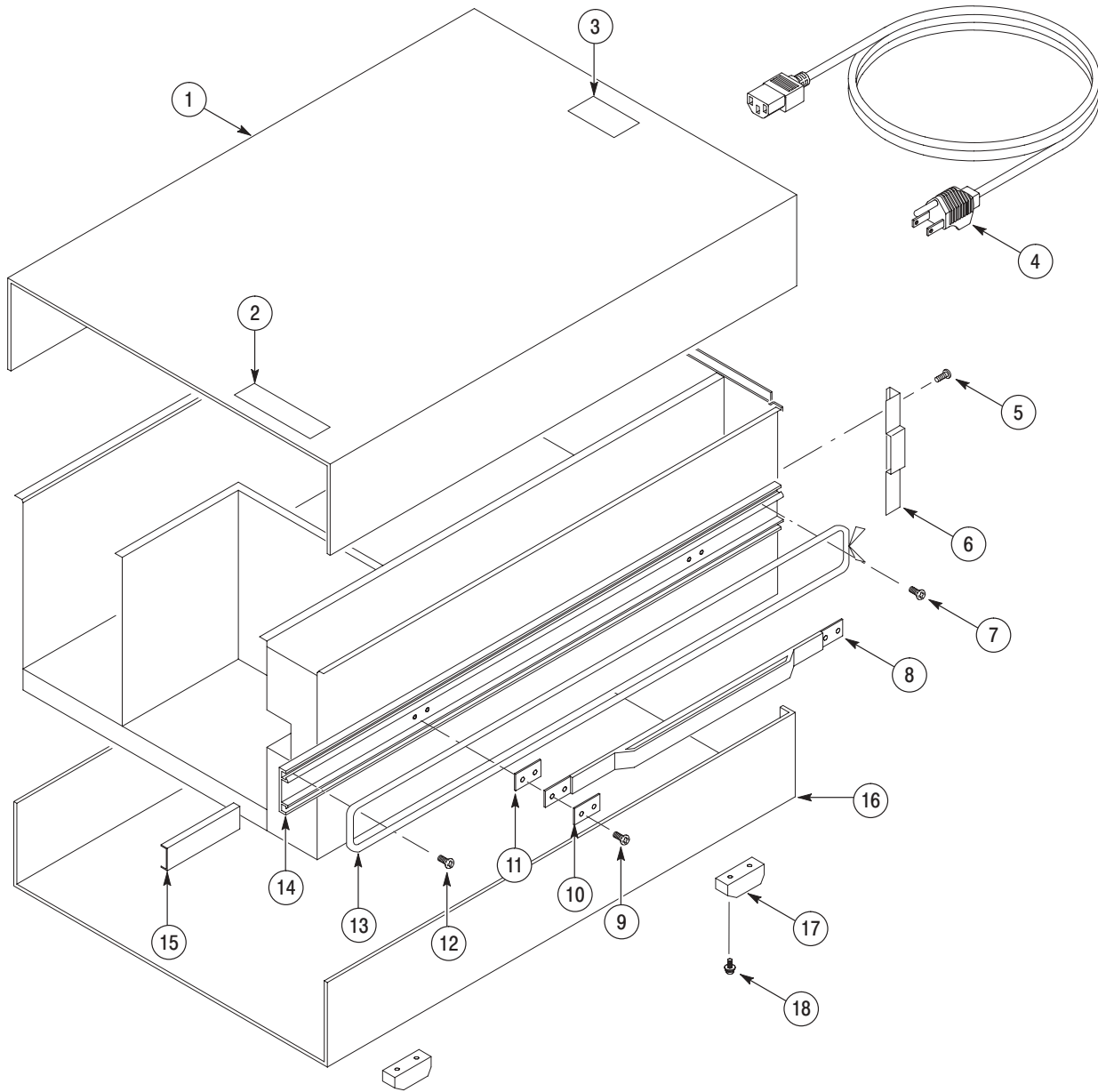


Figure 10-1: External modules

Replaceable Parts List

Fig. & Index Number	TektronixPart Number	Serial No. Effective	Serial No. Discont'd	Qty	Name & Description	Mfr. Code	Mfr. Part Number
10-2							
-1	650-A755-XX			1	FRAME ASSY:FRAME KIT	80009	
-2	211-0965-XX			2	SCREW,MACHINE:M3X8MM L,PNH,STL,ZN-CM2, CROSS REC	80009	
-3	211-0945-XX			2	SCREW,MACHINE:M4X8MM L,STL,ZN-C,CROSS REC	80009	
-4	407-A636-XX			1	BRACKET,ANGLE	80009	
-5	211-0871-XX			1	SCREW,MACHINE:M3X6MM L,PNH,STL,ZN PL,CROSS REC W/FLAT(7MM OD) & LOCK WASHER	80009	
-6	386-A836-XX			1	PLATE,LATCH	80009	
-7	348-1433-XX			140 CM	SHIELD GASKET	80009	
-8	211-0965-XX			2	SCREW,MACHINE:M3X8MM L,PNH,STL,ZN-CM2, CROSS REC	80009	
-9	119-B074-XX			1	DISPLAY MONITOR:12.1INCH,LCD,TFT,1024X768,XGA	80009	
-10	220-0222-XX			2	NUT,PLATE:SST	S0482	220-0222-00
-11	361-1734-XX			2	SPACER,PLATE:STL	S0482	361-1734-00
-12	210-1499-XX			4	WASHER,PLAIN:#4,STL MFZN-C	80009	
-13	211-A039-XX			4	SCREW,MACHINE:M4X14MM L,PNH,STL ZN PL,CROSS REC, W/FLAT & LOCK WASHER	80009	
-14	211-0871-XX			10	SCREW,MACHINE:M3X6MM L,PNH,STL,ZN PL,CROSS REC, W/FLAT(7MM OD) & LOCK WASHER	80009	
-15	211-0871-XX			2	SCREW,MACHINE:M3X6MM L,PNH,STL,ZN PL,CROSS REC, W/FLAT(7MM OD) & LOCK WASHER	80009	
-16	220-0193-XX			1	NUT,PLAIN,HEX:M4X7MM HEX,STL,ZN-C	80009	
-17	348-0949-XX			1	GROMMET,RING:15MM ID,BLACK NYLON	80009	
-18	358-A013-XX			1	GROMMET,PLASTIC:NYLON,BLACK,6.4-7.4MM DIA CABLE, STRAIGHT	80009	
-19	211-0751-XX			2	SCREW,ASSEM WSHR:M3X8MM,PNH,STL ZN PL, W/FLAT & LOCK WSHR	80009	
-20	337-A097-XX			1	SHIELD,ELEC:FRONT STL	80009	
-21	343-1569-XX			1	CLAMP	80009	
-22	211-0871-XX			2	SCREW,MACHINE:M3X6MM L,PNH,STL,ZN PL,CROSS REC, W/FLAT(7MM OD) & LOCK WASHER	80009	
-23	441-A260-XX			1	CHASSIS,FRONT	80009	

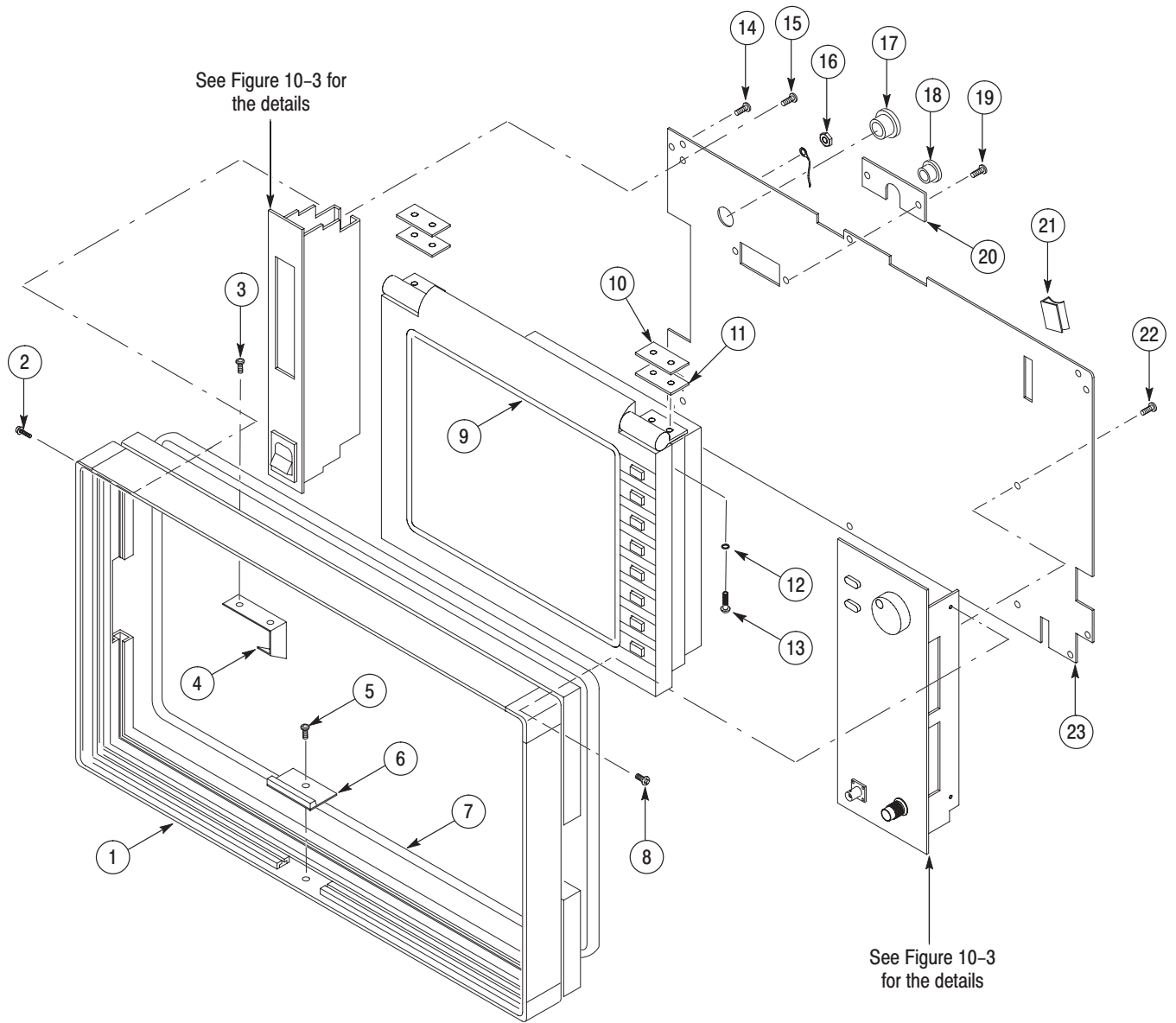


Figure 10-2: Front-panel assembly

Replaceable Parts List

Fig. & Index Number	TektronixPart Number	Serial No. Effective	Serial No. Discont'd	Qty	Name & Description	Mfr. Code	Mfr. Part Number
10-3							
-1	174-B824-XX			1	CA ASSY,SP,ELEC:3,26AWG,W/SWITCH,30CM L,W2	80009	
-2	333-A395-XX			1	PANEL,FRONT:LEFT	80009	
-3	386-A835-XX			1	SUBPANEL ASSY,FRONT:LEFT	80009	
-4	352-0858-XX			1	HOLDER,LED:PLASTIC	S4238	30-0603
-5	174-B825-XX			1	CA ASSY,SP,ELEC:2,26AWG,W/LED,YELLOW,30CM L,W5	80009	
-6	366-1562-XX			1	KNOB ASSEMBLY:DOVE GRAY,6MM ID X 38MM ODX 11MM H,DIMPLE	80009	
-7	213-0020-XX			1	SETSCREW: 6-32 X 0.125,STL BLK OXD,HEX SKT,CUP PT	3M099	ORDER BY DESCRIPTION
-8	333-A396-XX			1	PANEL,FRONT:RIGHT,WCA330	80009	
	333-A397-XX			1	PANEL,FRONT:RIGHT,WCA380	80009	
-9	386-A834-XX			1	SUBPANEL ASSY,FRONT:RIGHT	80009	
-10	366-1591-XX			34	PUSH BUTTON:DOVE GRAY,ABS	80009	
-11	366-0753-XX			12	PUSH BUTTON:TEK TAN,ABS	80009	
-12	671-B043-XX			1	CIRCUIT BD ASSY:A60 FRONT PANEL,389-B051-XX WIRED	80009	
-13	211-0871-XX			6	SCREW,MACHINE:M3X6MM L,PNH,STL,MFZN-C, CROSS REC W/FLAT & LOCK WASHER	80009	
-14	260-2497-XX			1	SWITCH,ROTARY:ENCODER,5VDC,70MA,INCREMENTAL, W/9CM L CABLE ASSY	80009	
-15	131-6608-XX			1	CONN,RF,JACK:N TO SMA,50OHM,PANEL MOUNT	80009	
-16	131-6607-XX			1	CONN,RF,JACK:BNC/FEMALE TO SMB/FEMALE,50OHM, PANEL MOUNT	80009	
-17	211-1022-XX			4	SCREW,MACHINE:M2.5X8MM L,PNH,STL,NI PL CROSS REC	80009	

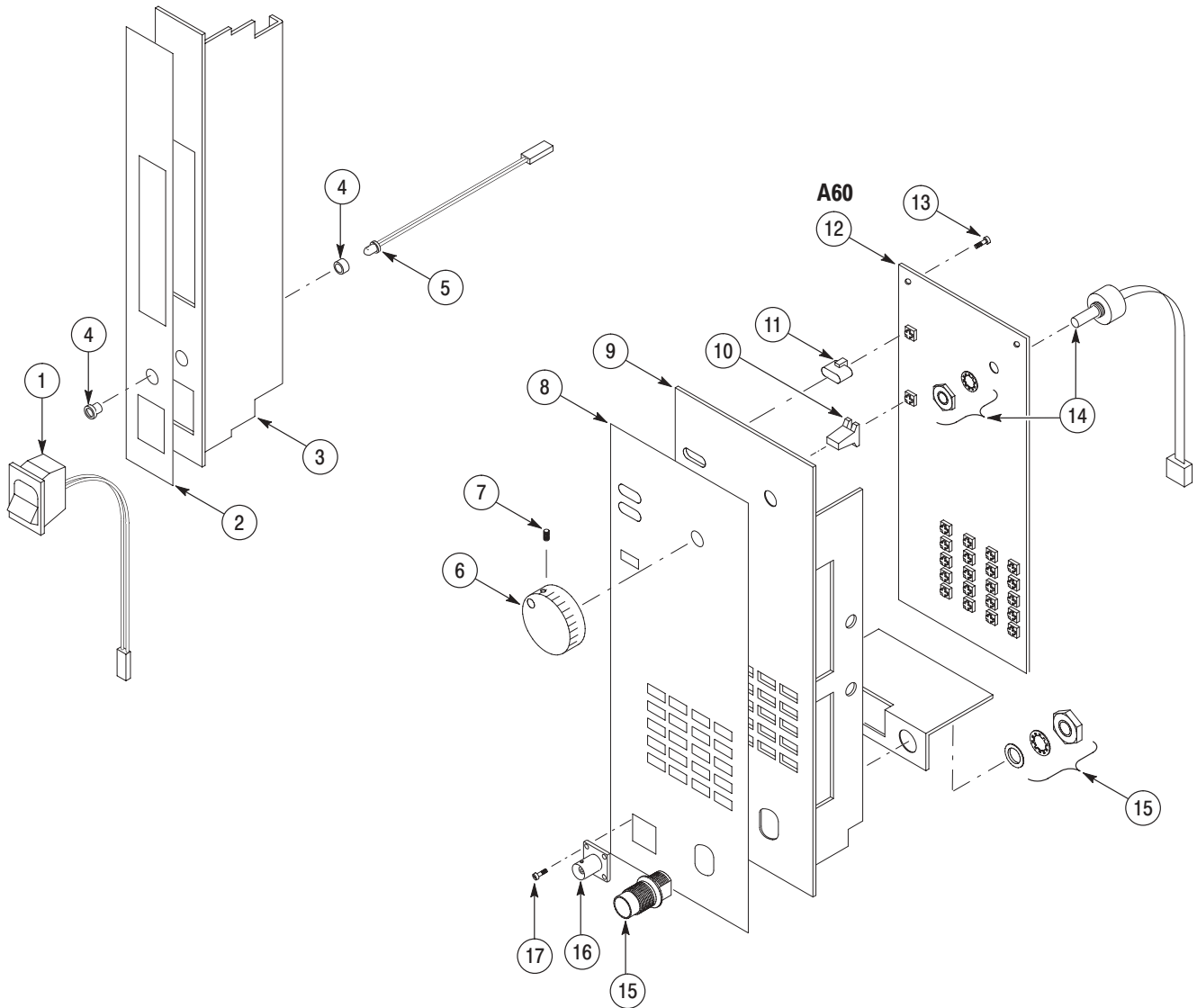


Figure 10-3: Front panel (left and right)

Replaceable Parts List

Fig. & Index Number	TektronixPart Number	Serial No. Effective	Serial No. Discont'd	Qty	Name & Description	Mfr. Code	Mfr. Part Number
10-4							
-1	348-0949-XX			1	GROMMET,RING:15MM ID,BLACK NYLON	80009	
-2	407-A632-XX			1	BRACKET,FAN	80009	
-3	119-6016-XX			1	FAN,TUBE AXIAL:119-4322-XX W/CONN,68CM L,W75	80009	
-4	220-0193-XX			4	NUT,PLAIN,HEX:M4X7MM HEX,STL,ZN-C	80009	
-5	211-0871-XX			4	SCREW,MACHINE:M3X6MM L,PNH,STL,MFZN-C, CROSS REC W/FLAT & LOCK WASHER	80009	
-6	119-5953-XX			1	FLOPPY DISK DRIVE:3.5INCH 3MODE W/INTERFACE	80009	
-7	211-0854-XX			4	SCREW,MACHINE:M2.6X4MM L,BDGH,STL,ZN-C, CROSS REC,JIS B1111	80009	
-8	407-4630-XX			1	BRACKET,FDD:AL	80009	
-9	174-4123-XX			2	CA ASSY,SP,ELEC:1,18AWG,12CM L,W/CONN,W093,W094	80009	
-10	211-0871-XX			1	SCREW,MACHINE:M3X6MM L,PNH,STL,ZN-C, CROSS REC,W/FLAT(7MM OD) & LOCK WASHER	80009	
-11	211-0871-XX			3	SCREW,MACHINE:M3X6MM L,PNH,STL,ZN-C, CROSS REC,W/FLAT(7MM OD) & LOCK WASHER	80009	
-12	174-2775-XX			1	WIRE,ELECTRICAL:FLAT FLEX,W76	80009	
-13	174-4105-XX			1	CA ASSY,SP,ELEC:3,26AWG,30CM L,W/CONN & 156-A336-XX TEMP SENSOR	80009	
-14	122-A037-XX			1	ANGLE,RETAINER:STL	80009	
-15	211-1028-XX			2	SCREW,MACHINE:M4X8MM L,PNH,STL,ZN-C PL, CROSS REC,W/FLAT & LOCK WASHER	80009	
-16	211-0658-XX			4	SCR,ASSEM WSHR:6-32X0.312,PNH,STL ZN-CM1, POSIDRIV MACHINE	93907	821-12790-024
-17	407-A633-XX			1	BRACKET,CMPNT:HDD & P/S	80009	
-18	211-1028-XX			4	SCREW,MACHINE:M4X8MM L,PNH,STL,ZN-C PL, CROSS REC,W/FLAT & LOCK WASHER	80009	
-19	211-1028-XX			4	SCREW,MACHINE:M4X8MM L,PNH,STL,ZN-C PL, CROSS REC,W/FLAT & LOCK WASHER	80009	
-20	407-A634-XX			1	BRACKET,CMPNT:HDD	80009	
-21	119-B078-XX			1	HARD DISK UNIT:3.5",10.24GB,IDE(ATA-4)-I/F, WINDOWS 98 INSTALLED FOR WCA330	80009	
	119-B075-XX			1	HARD DISK UNIT:3.5",10.24GB,IDE(ATA-4)-I/F, WINDOWS 98 INSTALLED FOR WCA380	80009	
-22	174-4119-XX			1	CA ASSY,SP,ELEC:40,28AWG,25CM L,FLAT,W81	80009	
-23	174-4116-XX			1	CA ASSY,SP,ELEC:4,18AWG,15CM L,W/CONN FOR HDD,W77	80009	
-24	211-1028-XX			2	SCREW,MACHINE:M4X8MM L,PNH,STL,ZN-C PL, CROSS REC,W/FLAT & LOCK WASHER	80009	
-25	122-A036-XX			1	ANGLE,RETAINER:STL	80009	
-26	441-A255-XX			1	CHASSIS ASSY	80009	

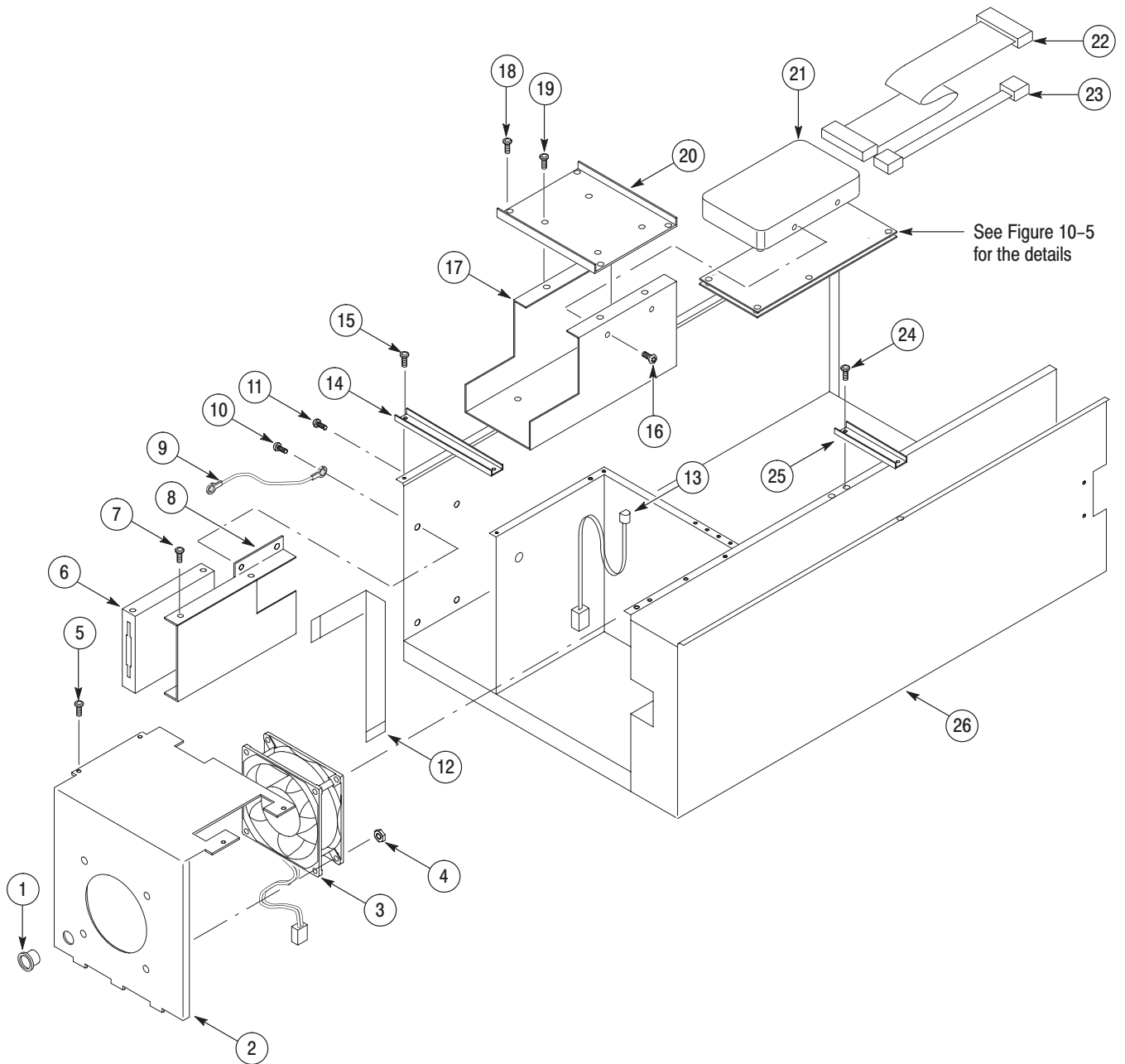


Figure 10-4: Inner chassis modules - 1

Replaceable Parts List

Fig. & Index Number	Tektronix Part Number	Serial No. Effective	Serial No. Discont'd	Qty	Name & Description	Mfr. Code	Mfr. Part Number
10-5							
-1	344-0557-XX			2	CLIP,CABLE:WIRE SADDLE,11.1MM X 14.7MM,66-NYLON	80009	
-2	211-0871-XX			6	SCREW,MACHINE:M3X6MM L,PNH,STL,MFZN-C, CROSS REC W/FLAT(7MM OD) & LOCK WASHER	80009	
-3	211-0871-XX			5	SCREW,MACHINE:M3X6MM L,PNH,STL,MFZN-C, CROSS REC W/FLAT(7MM OD) & LOCK WASHER	80009	
-4	129-A235-XX			5	SPACER,POST:30MM L,M3	80009	
-5	211-0871-XX			2	SCREW,MACHINE:M3X6MM L,PNH,STL,MFZN-C, CROSS REC W/FLAT(7MM OD) & LOCK WASHER	80009	
-6	352-A201-XX			1	HOLDER,CORE:AL,WCA330/380	80009	
-7	174-A027-XX			50 CM	WIRE,ELECTRICAL:30AWG,SOLID,125V,UL1827	80009	
-8	337-A197-XX			1	SHIELD,ELEC:TOP,BASEBAND	80009	
-9	671-B042-XX			1	CIRCUIT BD ASSY:A13 IF-A/D,389-B050-XX WIRED	80009	
-10	671-B041-XX			1	CIRCUIT BD ASSY:A12 IF-GAIN,389-B049-XX WIRED	80009	
-11	211-0871-XX			1	SCREW,MACHINE:M3X6MM L,PNH,STL,MFZN-C, CROSS REC W/FLAT(7MM OD) & LOCK WASHER	80009	
-12	337-4195-XX			1	SHIELD,ELEC:BOTTOM,BASEBAND BD,AL	80009	
-13	211-0945-XX			11	SCREW,MACHINE:M4X8MM L,STL,ZN-C,CROSS REC	80009	
-14	343-A337-XX			1	CLAMP,CABLE:CLIP LOCKING WIRE,PVC	80009	
-15	211-0945-XX			1	SCREW,MACHINE:M4X8MM L,STL,ZN-C,CROSS REC	80009	
-16	119-B064-XX			1	MODULE,RF:DOWN CONVERTER,IN DC-3GHZ, OUT 18MHZ/50MHZ (WCA330)	80009	
	119-B056-XX			1	MODULE,RF:DOWN CONVERTER,IN DC-8GHZ, OUT 18MHZ/50MHZ (WCA380)	80009	
-17	119-B065-XX			1	MODULE,RF:PRESELECTOR,LOCAL OSCILLATOR (WCA330)	80009	
	119-B057-XX			1	MODULE,RF:PRESELECTOR,LOCAL OSCILLATOR (WCA380)	80009	
-18	211-1028-XX			9	SCREW,MACHINE:M4X8MM L,PNH,STL,ZN-C PL, CROSS REC,W/FLAT & LOCK WASHER	80009	

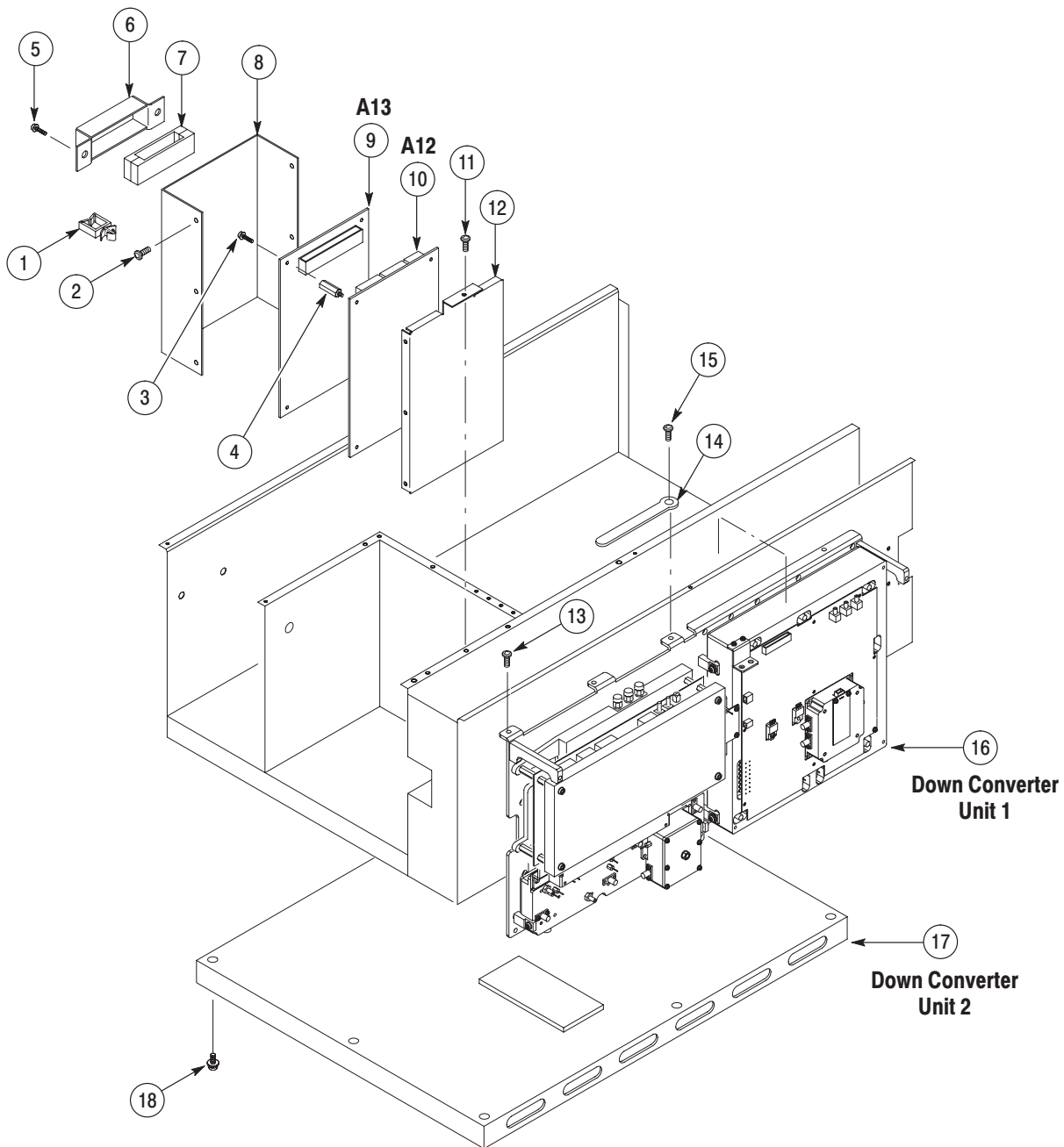


Figure 10-5: Inner chassis modules - 2

Replaceable Parts List

Fig. & Index Number	TektronixPart Number	Serial No. Effective	Serial No. Discont'd	Qty	Name & Description	Mfr. Code	Mfr. Part Number
10-6							
-1	211-0871-XX			6	SCREW,MACHINE:M3X6MM L,PNH,STL,ZN PL,CROSS REC W/FLAT(7MM OD) & LOCK WASHER	80009	
-2	671-B044-XX			1	CIRCUIT BD ASSY:A72 DC POWER-3,389-B052-XX WIRED	80009	
-3	386-A833-XX			1	PLATE,CKT BD:A72 DC POWER-3	80009	
-4	211-0871-XX			4	SCREW,MACHINE:M3X6MM L,PNH,STL,ZN PL,CROSS REC W/FLAT(7MM OD) & LOCK WASHER	80009	
-5	211-1028-XX			2	SCREW,MACHINE:M4X8MM L,PNH,STL,ZN-C PL, CROSS REC W/FLAT & LOCK WASHER	80009	
-6	119-5951-XX			1	FILTER,RFI:6A,250VAC,50/60HZ	80009	
-7	211-0871-XX			2	SCREW,MACHINE:M3X6MM L,PNH,STL,ZN PL,CROSS REC W/FLAT(7MM OD) & LOCK WASHER	80009	
-8	119-B058-XX			1	POWER SUPPLY:IN 85-264VAC,OUT +5V/2A,+15V/0.3A, -15V/0.2A	80009	
-9	211-0905-XX			8	SCREW,MACHINE:M3X6MM L,PNH,STL ZN-C,CROSS REC	80009	
-10	211-0945-XX			3	SCREW,MACHINE:M4X8MM L,STL,ZN-C,CROSS REC	80009	
-11	214-B258-XX			1	HEAT SINK:A71	80009	
-12	211-0871-XX			6	SCREW,MACHINE:M3X6MM L,PNH,STL,ZN PL,CROSS REC W/FLAT(7MM OD) & LOCK WASHER	80009	
-13	671-B049-XX			1	CIRCUIT BD ASSY:A70 DC POWER-1,389-B058-XX WIRED	80009	
-14	211-1028-XX			2	SCREW,MACHINE:M4X8MM L,PNH,STL,ZN-C PL, CROSS REC W/FLAT & LOCK WASHER	80009	
-15	407-A609-XX			1	BRACKET,CKT BD:AL	80009	
-16	119-5977-XX			1	POWER SUPPLY:IN 85-264VAC,OUT +48V/7.5A	80009	
-17	671-B050-XX			1	CIRCUIT BD ASSY:A71 DC POWER-2,389-B059-XX WIRED	80009	
-18	129-1512-XX			4	SPACER,POST:13MM L,M3 THRU STL ZN PL,5.5MM HEX	80009	
-19	211-0871-XX			4	SCREW,MACHINE:M3X6MM L,PNH,STL,ZN PL,CROSS REC W/FLAT(7MM OD) & LOCK WASHER	80009	

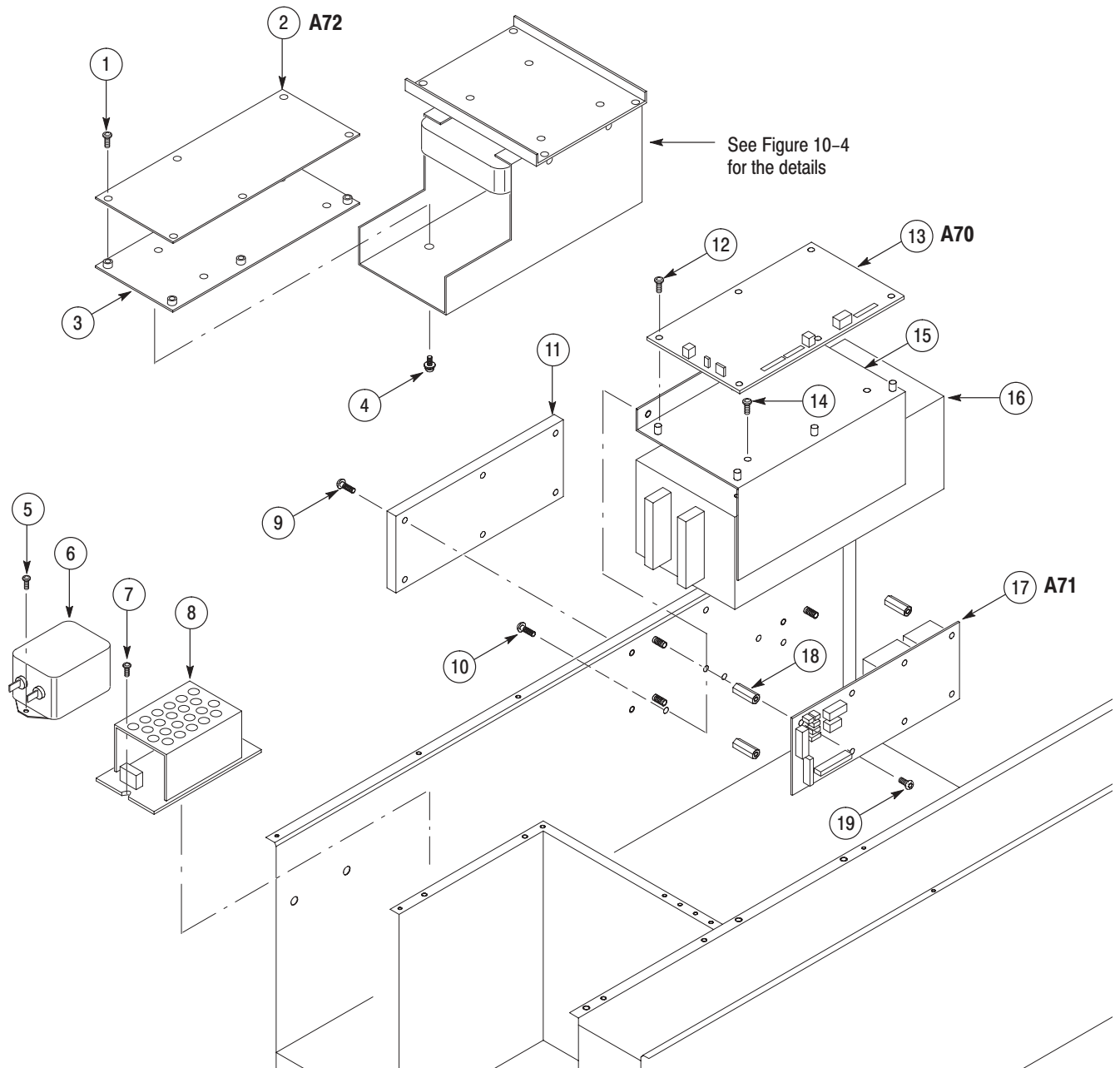


Figure 10-6: Power supply modules

Replaceable Parts List

Fig. & Index Number	TektronixPart Number	Serial No. Effective	Serial No. Discont'd	Qty	Name & Description	Mfr. Code	Mfr. Part Number
10-7							
-1	119-B076-XX			1	PIB INTERFACE CARD:ISA,WINDOWS95,IRQ CHANGED	80009	
-2	211-0871-XX			2	SCREW,MACHINE:M3X6MM L,PNH,STL,ZN PL,CROSS REC, W/FLAT(7MM OD) & LOCK WASHER	80009	
-3	119-B077-XX			1	CPU CARD:ISA/PCI,CELERON,433/466/500MHZ, W/LAN&SCSI&LCD,CPU&DIMM INSTALLED	80009	
-4	334-A481-XX			1	MARKER,IDENT:MKD LI-MN02	80009	
-5	211-0854-XX			2	SCREW,MACHINE:M2.6X4MM L,BDGH,STL,ZN-C, CROSS REC,JIS B1111	80009	
-6	200-A512-XX			1	COVER,VGA CONN	80009	
-7	343-A341-XX			1	RETAINER:CPU BD	80009	
-8	211-0871-XX			9	SCREW,MACHINE:M3X6MM L,PNH,STL,ZN PL,CROSS REC, W/FLAT(7MM OD) & LOCK WASHER	80009	
-9	426-2590-XX			1	ANGLE:RETAINER,STL	80009	
-10	407-A638-XX			1	BRACKET,VIDEO CARD	80009	
-11	343-A342-XX			1	RETAINER:DIMM,STL,WCA330/380	80009	
-12	211-1036-XX			1	SCREW,MACHINE:M2X6MM L,PNH,STL,ZN-C,CROSS REC, W/FLAT & LOCK WASHER	80009	
-13	211-0871-XX			1	SCREW,MACHINE:M3X6MM L,PNH,STL,ZN PL,CROSS REC, W/FLAT(7MM OD) & LOCK WASHER	80009	
-14	119-B052-XX			1	XGA CARD:PCI,LVDS OUTPUT,FOR LCD MODULE, MODIFIED 119-5954-00(KL-G12P)	80009	
-15	174-4120-XX			1	CA ASSY,SP,ELEC:26,30AWG,110CM L,W/CONN,W/SHIELD, W82	80009	
-16	407-4652-XX			-	BRACKET,ANGLE:LEFT,SST	80009	
-17	358-A038-XX			-	BUSHING,SLEEVE:2.35MM IDX3.35MM ODX2.0MM L,STL, MFZN-C	80009	
-18	211-0871-XX			-	SCREW,MACHINE:M3X6MM L,PNH,STL,ZN PL,CROSS REC, W/FLAT(7MM OD) & LOCK WASHER	80009	
-19	407-4651-XX			-	BRACKET,ANGLE:RIGHT,SST	80009	
-20	211-1037-XX			-	SCREW,MACHINE:M2.3X6MM L,PNH,STL,ZN-C, CROSS REC,W/FLAT & LOCK WASHER	80009	
-21	671-B107-XX			1	CIRCUIT BD ASSY:A40 MEMORY,389-B057-XX WIRED WITH EJECTOR	80009	
-22	671-B108-XX			1	CIRCUIT BD ASSY:A30 FFT,389-B056-XX WIRED WITH EJECTOR	80009	
-23	671-B110-XX			1	CIRCUIT BD ASSY:A22 WIDE-ADC,389-B055-XX WIRED WITH EJECTOR	80009	
-24	671-B109-XX			1	CIRCUIT BD ASSY:A20 DDC,389-B054-XX WIRED WITH EJECTOR	80009	
-25	671-B078-XX			1	A50 MOTHER BD	80009	
-26	211-0871-XX			16	SCREW,MACHINE:M3X6MM L,PNH,STL,ZN PL,CROSS REC, W/FLAT(7MM OD) & LOCK WASHER	80009	

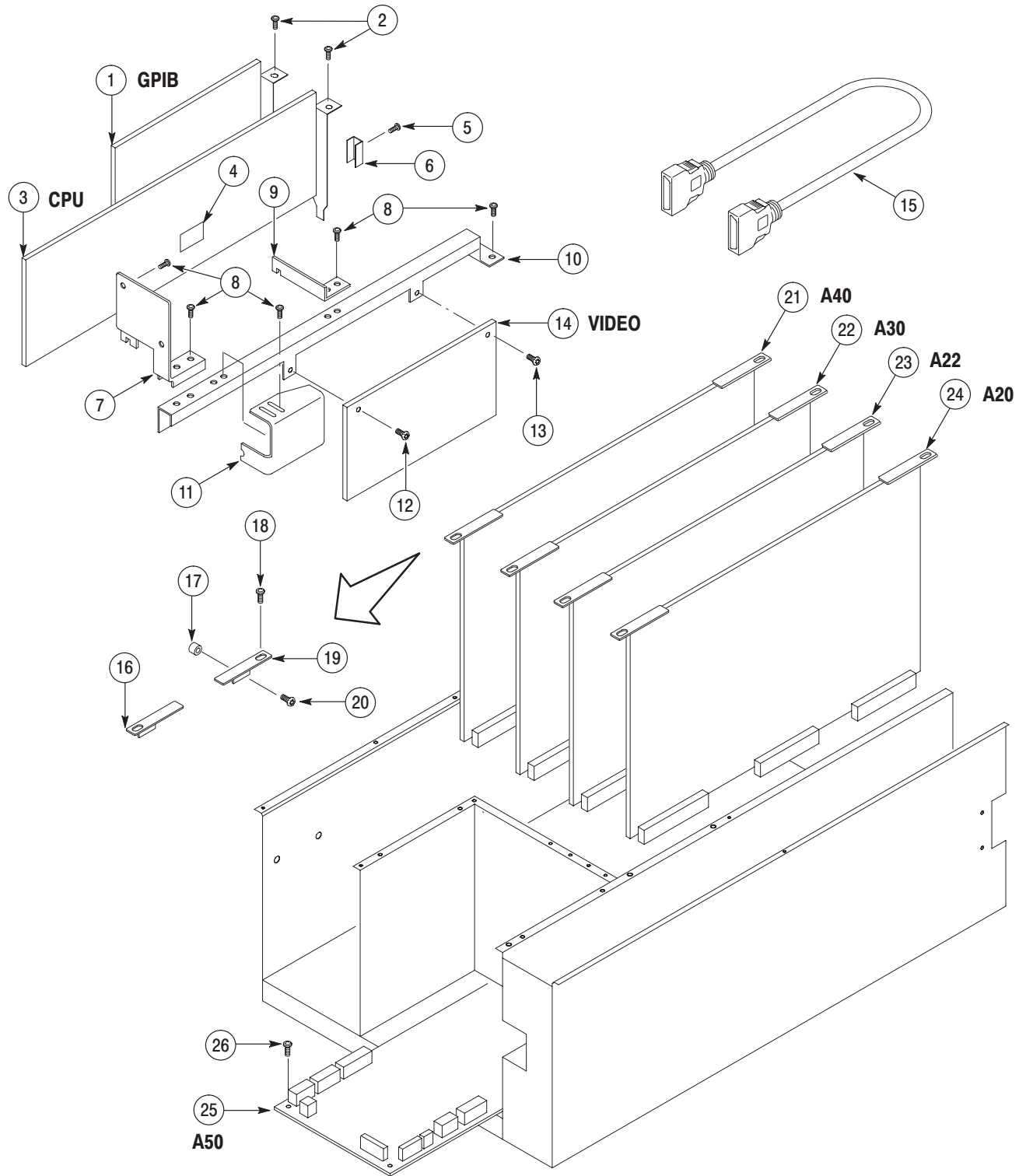


Figure 10-7: Mother board and its daughter boards

Replaceable Parts List

Fig. & Index Number	TektronixPart Number	Serial No. Effective	Serial No. Discont'd	Qty	Name & Description	Mfr. Code	Mfr. Part Number
10-8							
-1	333-A398-XX			1	PANEL ASSY,REAR	80009	
-2	260-2740-XX			1	SWITCH,ROCKER:DPST,250VAC,6A W/I-O MKD	80009	
-3	119-2683-XX			1	FILTER,RFI:6A,250VAC,50/60HZ,LEAK=0.4MA, DCRES=0.1OHM	80009	
-4	211-1021-XX			2	SCREW,MACHINE:M3X8MM L,FLH,BRS NI PL,CROSS REC	80009	
-5	333-A399-XX			1	PANEL,REAR:BLANK	80009	
-6	211-1025-XX			4	SCREW,MACHINE:M3X8MM L,TRUSS HD,STL,NI PL, CROSS REC	80009	
-7	174-4013-XX			1	CA ASSY,SP,ELEC:PRINTER,W84	80009	
-8	334-1378-XX			1	MARKER,IDENT:MKD SERIAL NO. FOR SONY/TEK	80009	
-9	211-1027-XX			3	SCREW,MACHINE:M4X8MM L,TRUSS HD,BRS NI PL, CROSS REC	80009	
-10	211-1022-XX			16	SCREW,MACHINE:M2.5X8MM L,PNH,STL,NI PL CROSS REC	80009	
-11	131-6607-XX			4	CONN,RF,JACK:BNC/FEMALE TO SMB/FEMALE,50OHM, PANEL MOUNT	80009	
-12	213-1116-XX			4	SCREW,MACHINE:M4X30MM L,TRUSS HD,STL,NI PL, CROSS REC	80009	
-13	200-4474-XX			1	GUARD,FAN:AL	80009	
-14	119-6015-XX			1	FAN,TUBE AXIAL:119-A746-XX TUDC12D4,30CM L,W/CONN	80009	
-15	211-0945-XX			4	SCREW,MACHINE:M4X8MM L,STL,ZN-C,CROSS REC	80009	
-16	211-0871-XX			1	SCREW,MACHINE:M3X6MM L,PNH,STL,ZN PL,CROSS REC, W/FLAT(7MM OD) & LOCK WASHER	80009	
-17	333-4301-XX			1	PANEL,READ:BLANK,STL	S0482	333-4301-00
-18	348-A120-XX			40 CM	GASKET SHIELD:CONDUCTIVE URETHAN FORM, 2MMX4MM,W/ADHESIVE	80009	
-19	348-A116-XX			20 CM	GASKET SHIELD:CONDUCTIVE URETHAN FORM, 1MMX3MM,W/ADHESIVE	80009	
-20	220-0193-XX			1	NUT,PLAIN,HEX:M4X7MM HEX,STL,ZN-C	80009	
-21	195-3990-XX			1	LEAD,ELECTRICAL:AWG18,100MM L,5-4,W/LUG,W92	6E390	ORDER BY DESCRIPTION
-22	210-0008-XX			1	WASHER,LOCK:#8 INTL,0.02 THK,STL CD PL	80009	
-23	174-B837-XX			1	CA ASSY,SP,ELEC:2,18AWG,W/CONN,50CM L,W090	80009	
-24	174-B853-XX			1	CA,ASSY,SP ELEC:10,28AWG,23CM L,FLAT,W088	80009	

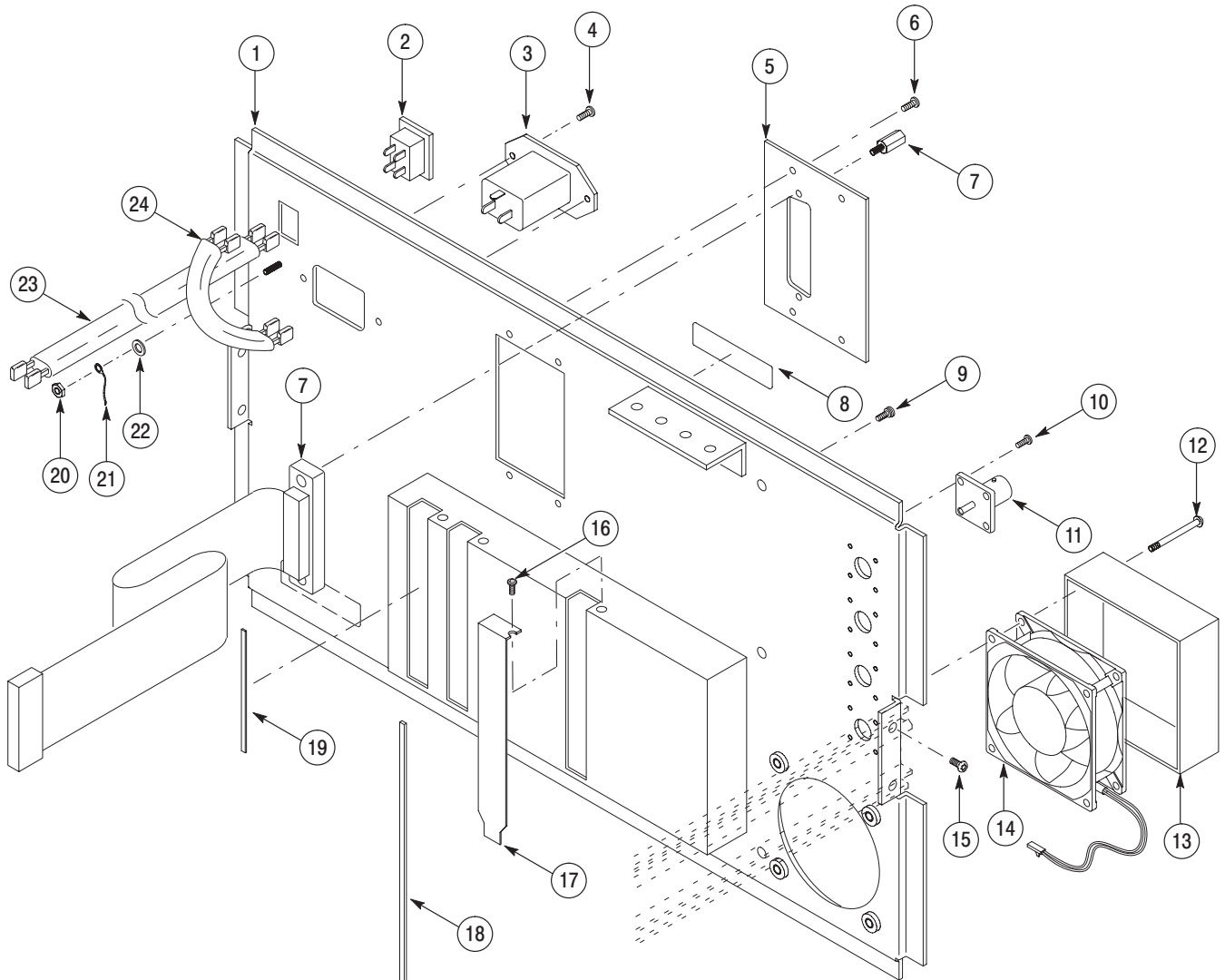


Figure 10-8: Rear panel assembly

Replaceable Parts List

Fig. & Index Number	TektronixPart Number	Serial No. Effective	Serial No. Discont'd	Qty	Name & Description	Mfr. Code	Mfr. Part Number
INTERCONNECT CABLES							
	174-B578-XX			1	CA ASSY,RF:50OHM,1.5D02W,75CM L,SMB/L-SMB/L,W27	80009	
	174-B799-XX			1	CA ASSY,RF:50OHM,SEMI-FLEX,W/SHEATH,SMA-SMA,18CM L,W10	80009	
	174-B801-XX			1	CA ASSY,RF:50OHM,SEMI-FLEX,W/SHEATH,SMA-SMA,35CM L,W13	80009	
	174-B802-XX			1	CA ASSY,RF:50OHM,SEMI-FLEX,W/SHEATH,SMA-SMA/L,60CM L,W203 (WCA380)	80009	
	174-B806-XX			1	CA ASSY,RF:50OHM,COAX,1.5D-2W,SMA/L-SMB/L,22CM L,W25	80009	
	174-B807-XX			1	CA ASSY,RF:50OHM,COAX,1.5D-2W,SMA/L-SMB/L,55CM L,W30	80009	
	174-B808-XX			1	CA ASSY,RF:50OHM,COAX,1.5D-2W,SMB/L-SMB/L,65CM L,W11	80009	
	174-B809-XX			1	CA ASSY,RF:50OHM,COAX,1.5D-2W,SMA-SMB/L,75CM L,W12	80009	
	174-B810-XX			1	CA ASSY,RF:50OHM,COAX,1.5D-2W,SMA/L-SMA/L,45CM L,W16	80009	
	174-B811-XX			1	CA ASSY,RF:50OHM,COAX,1.5D-2W,SMB/L-SMB/L,55CM L,W17	80009	
	174-B812-XX			2	CA ASSY,RF:50OHM,COAX,1.5D-2W,SMB/L-SMB/L,85CM L,W34,W35	80009	
	174-B823-XX			1	CA ASSY,SP,ELEC:16,26AWG,W/CONN BOTH END,40CM L,W43	80009	
	174-B824-XX			1	CA ASSY,SP,ELEC:3,26AWG,W/SWITCH,30CM L,W2	80009	
	174-B825-XX			1	CA ASSY,SP,ELEC:2,26AWG,W/LED,YELLOW,30CM L,W5	80009	
	174-B826-XX			1	CA ASSY,SP,ELEC:10,26AWG,W/CONN BOTH END,15CM L,W44	80009	
	174-B827-XX			1	CA ASSY,SP,ELEC:6,26AWG,W/CONN BOTH END,30CM L,W45	80009	
	174-B828-XX			1	CA ASSY,SP,ELEC:2,26AWG,W/CONN BOTH END,25CM L,W46	80009	
	174-B829-XX			1	CA ASSY,SP,ELEC:8,26AWG,W/CONN BOTH END,20CM L,W47	80009	
	174-B830-XX			1	CA ASSY,SP,ELEC:2,18AWG,W/CONN BOTH END,15CM L,W48	80009	
	174-B831-XX			1	CA ASSY,SP,ELEC:3,26AWG,W/CONN BOTH END,42CM L,W51	80009	
	174-B832-XX			1	CA ASSY,SP,ELEC:4,26AWG,W/CONN BOTH END,30CM L,W53	80009	
	174-B833-XX			1	CA ASSY,SP,ELEC:5,26AWG,W/CONN BOTH END,10CM L,W54	80009	
	174-B835-XX			1	CA ASSY,SP,ELEC:5,26AWG,W/CONN,30CM L,W61	80009	
	174-B836-XX			1	CA ASSY,SP,ELEC:5,28AWG,W/CONN,14CM L,W87	80009	

Replaceable Parts List (Cont.)

Fig. & Index Number	Tektronix Part Number	Serial No. Effective	Serial No. Discont'd	Qty	Name & Description	Mfr. Code	Mfr. Part Number
	174-B838-XX			1	CA ASSY,SP,ELEC:10CON,18AWG,20CM,10P-SDN-A,5557-10R,W86	80009	
	174-B840-XX			1	CA ASSY,SP,ELEC:40,28AWG,50CM L,FLAT,W/2X20 CONN,W83	80009	
	174-B841-XX			1	CA ASSY,SP,ELEC:1X16,26AWG,13CM L,W/CONN,W24	80009	
	174-B842-XX			1	CA ASSY,SP,ELEC:1X6,26AWG,10CM L,W/CONN,W40	80009	
	174-B849-XX			1	CA ASSY,SP,ELEC:3,26AWG,W/CONN BOTH END,120CM L,W62	80009	
	174-3820-XX			3	CA ASSY,RF:50OHM,1.5D-2W,40CM L,SMB/L-SMB/L,W22,W23,W33	80009	
	174-4098-XX			1	CA ASSY,SP,ELEC:10,28AWG FLAT,18CM L,W/CONN,W41	80009	
	174-4099-XX			1	CA ASSY,SP,ELEC:10,26AWG,10CM L,W/CONN,W42	80009	
	174-4100-XX			1	CA ASSY,RF:50OHM,COAX,1.5D-2W,3.5MM D,23CM L,SMB(RTANG)/SMB(RTANG),W32	80009	
	174-4102-XX			2	CA ASSY,RF:50OHM,1.5D-2W,10CM L,SMB/L-SMB/L,W21,W28	80009	
	174-4107-XX			1	CA ASSY,SP,ELEC:6,18AWG,41CM L,W/CONN BOTH ENDS,W50	80009	
	174-4109-XX			1	CA ASSY,SP,ELEC:6,18AWG,35CM L,W/CONN BOTH ENDS,W52	80009	
	174-4113-XX			1	CA ASSY,SP,ELEC:2,18AWG,30CM L,W/CONN,W72	80009	
	174-4117-XX			1	CA ASSY,SP,ELEC:6,18AWG,27CM L,W/CONN BOTH ENDS,W79	80009	
	174-4118-XX			1	CA ASSY,SP,ELEC:34,28AWG,25CM L,FLAT,W80	80009	
	174-4124-XX			1	CA ASSY,SP,ELEC:2,18AWG,10CM L,W/FASTON & LUG,W95	80009	
	174-4127-XX			2	CA ASSY,RF:50OHM,COAX,1.5D-2W,3.5MM D,35CM L,SMB(RTANG)/SMB(RTANG),W20,W29	80009	
	174-4183-XX			2	CA ASSY,RF:50OHM,COAX,1.5D-2W,3.5MM D,15CM L,SMB(RTANG)/SMB(RTANG),W26,W31	80009	

Replaceable Parts List

Fig. & Index Number	TektronixPart Number	Serial No. Effective	Serial No. Discont'd	Qty	Name & Description	Mfr. Code	Mfr. Part Number
STANDARD ACCESSORIES							
-----				1	CABLE ASSY,PWR,:3,18 AWG,92 L (STANDARD CABLE - SEE FIG 10-1-4)	80009	
	161-0066-09			1	CA ASSY,PWR:3,1.0MM SQ,250V/10A,2.5 M (OPTION A1 - EUROPEAN)	S3109	198-010
	161-0066-10			1	CA ASSY,PWR:3,1.0MM SQ,240V/10A,2.5 M (OPTION A2 - UNITED KINGDOM)	S3109	209010
	161-0066-11			1	CA ASSY,PWR:3,1.0MM SQ,250V/10A,2.5 M (OPTION A3 - AUSTRALIAN)	S3109	198-010
	161-0066-12			1	CA ASSY,PWR:3,18 AWG,250/10A,98 INCH L (OPTION A4 - NORTH AMERICAN)	2W733	ORDER BY DESC
	161-0154-XX			1	CA ASSY,PWR:3,0.75MM SQ,250V/10A,2.5 M (OPTION A5 - SWITZERLAND)	S3109	ORDER BY DESC
	119-B061-XX			1	KEYBOARD ASSY:PS2 88 ENGLISH KEYBOARD	80009	
	119-B063-XX			1	MOUSE:PS/2,2-BUTTON WHITE GRAY	80009	
	103-0045-XX			1	ADPTR,N,ELEC:FEMALE BNC TO MALE N	80009	
	070-A792-XX			1	MANUAL,TECH:USER,ENGLISH VERSION (WCA330/WCA380)	80009	
	070-A794-XX			1	MANUAL,TECH:PROGRAMMER,ENGLISH VERSION (WCA330/WCA380)	80009	
OPTIONAL ACCESSORIES							
	016-1754-XX			1	FIELD INSTALLATION KIT:OPTION-1R;3066	80009	
	070-A795-XX			1	MANUAL,TECH:SERVICE,ENGLISH VERSION (WCA330/WCA380)	80009	
	062-A250-XX			1	SOFTWARE PACKAGE:CD-ROM,AWG520 SETUP DISK	80009	
	020-A041-XX			1	COMPONENT KIT:SERVICE MANUAL(070-A795-XX) AND AWG520 SETUP DISK(062-A250-XX)	80009	